

TECHNICAL MANUAL

**ORGANIZATIONAL, DIRECT SUPPORT, AND
GENERAL SUPPORT MAINTENANCE MANUAL
(INCLUDING REPAIR PARTS AND SPECIAL
TOOLS LISTS)
FOR
HEATERS, VEHICULAR COMPARTMENT:**

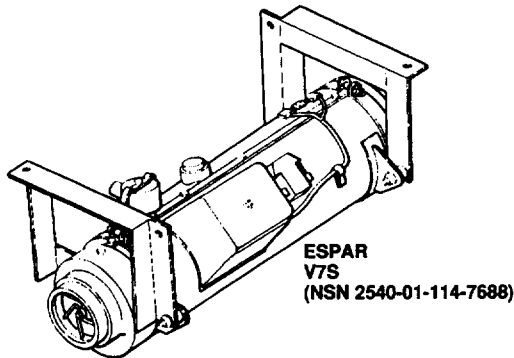
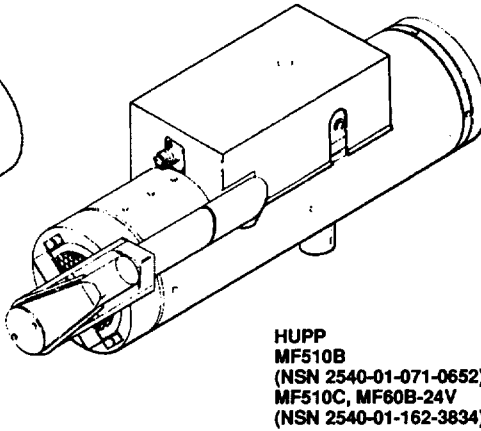
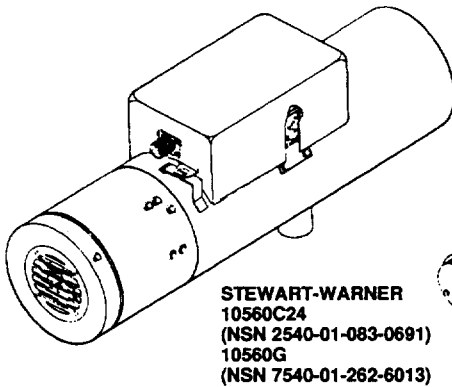
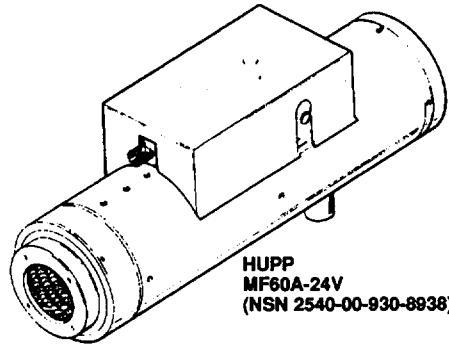
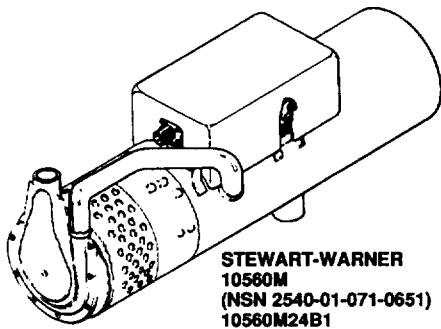

INTRODUCTION PAGE 1-1

ORGANIZATIONAL MAINTENANCE PAGE 2-1

DIRECT SUPPORT AND GENERAL SUPPORT MAINTENANCE PAGE 3-1
--

DIRECT SUPPORT AND GENERAL SUPPORT TEST PROCEDURES PAGE 3-248
--

MAINTENANCE ALLOCATION CHART PAGE B-1

REPAIR PARTS AND SPECIAL TOOLS LISTS PAGE D-1

INDEX PAGE Index-1

Approved for public release; distribution is unlimited

*This manual supersedes TM 9-2540-205-24&P, dated 18 October 1984

**HEADQUARTERS, DEPARTMENT OF THE ARMY
APRIL 1992**

WARNING

Particles blown by compressed air are hazardous. Do not exceed 30 psi (207 kPa) air pressure. Make certain the air stream is directed away from user and other personnel in the area. To prevent injury, user must wear protective goggles or face shield when using compressed air.

WARNING

Dry cleaning solvent PD-680 is both toxic and flammable. Wear protective goggles and gloves, and use only in well-ventilated area. Avoid contact with skin, eyes, and clothes, and don't breathe vapors. Do not use near open flame or excessive heat. The flashpoint is 100° F to 138° F (38° C to 59° C). If you become dizzy while using dry cleaning solvent, get fresh air immediately, and get medical aid. If contact with eyes is made, wash your eyes with water, and get medical aid immediately.

WARNING

The overheat switch does not control heater temperature. It is a factory-adjusted safety device. Any attempt to adjust this switch may result in injury to personnel.

WARNING

Do not try to start a flooded heater with excessive amounts of fuel inside. Explosion may occur, resulting in injury or death to personnel.

WARNING

The flame detector switch does not control heater temperature. Misadjustment of flame detector switch can cause damage to the heater and may result in injury to personnel. Detector switch must be adjusted when heater is cool.

WARNING

Only adjust flame detector switch when heater is off and cool. Hot or operating heater can cause serious injury to personnel.

WARNING

Stewart-Warner 10560C24, 1056M, 10560M24B1 and 10560G heaters must not be operated without rubber gaskets covering the ignitor. Failure to install this gasket could cause deadly carbon monoxide gas to enter the vehicle and result in personnel injury or death.

WARNING

The fuels this heater runs on are very explosive. Do not smoke or allow open flame nearby when performing these adjustments. Serious injury or death to personnel could result if this warning is not observed.

WARNING

Fuel burns easily. Fumes are explosive. Do not smoke or allow open flame nearby when working. Failure to observe these precautions could cause serious injury or death.

WARNING

Heat exchanger linings contain asbestos fibers. Protective mask must be worn while performing this task. Failure to do so could result in injury or death to personnel.

WARNING

Never operate heater Inside without venting the exhaust out of the test area. Heaters produce carbon monoxide gas. injury or death to personnel could result.

WARNING

Always have a fire extinguisher handy. Never perform the overheat test alone; have someone with you.

WARNING

Do not touch the end of the heat exchanger when the heater is operating. The extremely high operating temperature of the heat exchanger can cause serious burns.

For first aid information, refer to FM 21-11.

Technical Manual
NO. 9-2540-205-2481P

HEADQUARTERS
DEPARTMENT OF THE ARMY
Washington D. C., 10 April 1992

ORGANIZATIONAL, DIRECT SUPPORT, AND GENERAL SUPPORT
MAINTENANCE MANUAL
(INCLUDING REPAIR PARTS AND SPECIAL TOOLS LISTS)
FOR
HEATERS, VEHICULAR COMPARTMENT:

STEWART-WARNER
1056OC24 (NSN 2540-01-063-0691)
10560M (NSN 2540-01-071-0651)
10560M24B1 (NSN 2540-01-169-5159)
10560G (NSN 25404)1-262-6013)

HUPP
MF510B (NSN 2540-01-071-0652)
MF510C, MF60B-24V (NSN 2540-01-162-3834)
MF60A-24V (NSN 2540-00-930-8838)

ESPAR
V7S (NSN 2540-01-114-7688)

CURRENT AS OF APRIL 1992

REPORTING ERRORS AND RECOMMENDING IMPROVEMENTS

You can help improve this manual. If you find any mistakes, or if you know of a way to improve the procedures, please let us know. Mail your letter, DA Form 2028 (Recommended Changes to Publications and Blank Forms), or DA Form 2028-2 located in the back of this manual directly to: Commander, U.S. Army Tank-Automotive Command, ATTN: AMSTA-MB, Warren, MI 48397-5000. A reply will be sent to you.

Approved for public release; distribution is unlimited.

TABLE OF CONTENTS

	PAGE
CHAPTER 1	INTRODUCTION 1-1
Section I.	General Information 1-1
Section II	Equipment Description and Data 1-2
Section III.	Principles of Operation 1-13
CHAPTER 2	ORGANIZATIONAL MAINTENANCE 2-1
Section I.	General Maintenance Instructions 2-1
Section II.	Repair Parts, Special Tools; Test, Measurement and Diagnostic Equipment (TMDE); and Support Equipment 2-5

* This manual supersedes TM 9-2540-205-24&P, dated 18 October 1984.

TABLE OF CONTENTS-CONTINUED

CHAPTER 2	ORGANIZATIONAL MAINTENANCE-CONTINUED		
Section III.	Service Upon Request	2-5	
Section IV.	Organizational Preventive Maintenance Checks and Services (PMCS)	2-6	
Section V.	Organizational Troubleshooting Procedures	2-15	
Section VI,	Organizational Maintenance Procedures	2-30	
Section VII..	Start-Up and Shut-Down Procedures	2-56	
CHAPTER 3	DIRECT SUPPORT AND GENERAL SUPPORT MAINTENANCE	3-1	
Section 1.	Repair Parts, Special Tools; Test, Measurement and Diagnostic Equipment (TMDE); and Support Equipment	3-1	
Section II.	Direct Support and General Support Troubleshooting Procedures	3-2	
Section III.	Direct Support and General Support Maintenance Procedures	3-26	
Section IV.	Direct Support and General Support Test Procedures	3-192	
		Page	Illus. Fig.
APPENDIX A	REFERENCES	A-1	
APPENDIX B	MAINTENANCE ALLOCATION CHART	B-1	
Section 1.	Introduction	B-1	
Section II	Maintenance Allocation Chart	B-4	
APPENDIX C	EXPENDABLE SUPPLIES AND MATERIALS LIST	C-1	
APPENDIX D	REPAIR PARTS AND SPECIAL TOOLS LISTS	D-1	
Section 1.	Introduction	D-1	
Section II.	Repair Parts List	D-7	
Group 22	BODY, CHASSIS AND HULL ACCESSORY ITEMS 2202—Accessory Items	D-7	
	Hupp Model Flame Detector Switch and Cover	1-1	1
	Hope Model Hi/LO Fire Relay Assembly	2-1	2
	Hupp Model Fuel Regulator Valve Assembly	3-1	3
	Hupp Model Thermostat and Combustion Chamber	4-1	4
	Hupp Model MF60A-24V Preheat Element, Burner Thermostat, Blower Assembly and Motor	5-1	5

TABLE OF CONTENTS-CONTINUED

	Hupp Models MF510B, MF510C, MF60B-24V Preheat Element, Burner Thermostat, Blower Assembly and Motor	6-1	6
	Stewart-Warner Model Ignitor, Flame Detector Switch, Overheat Switch and Ignition Control Assembly	7-1	7
	Stewart-Warner Model Fuel Metering Pulse Valve	8-1	8
	Stewart-Warner Models 10560G, 10560C24 Blower Assembly and Heat Exchanger	9-1	9
	Stewart-Warner 10560M, 10560M24B1 Blower Assembly and Heat Exchanger	10-1	10
	Stewart-Warner Model Burner Assembly	11-1	11
	ESPAR Model V7S Spark Generator, Resistor, Glow Plug, Temperature Sensor and Switch	12-1	12
	ESPAR Model V7S air Solenoid Valve and Wiring Harness	13-1	13
	ESPAR Model V7S Mounting Assembly	14-1	14
	ESPAR Model V7S Meter Pump and Fuel Pump	15-1	15
	ESPAR Model V7S Burner Assembly and Heat Exchanger	16-1	16
Group 94	REPAIR KITS	KIT-1	
Group 95	GENERAL USE STANDARDIZED PARTS Bulk Material	BULK-1	
Section III.	Special Tools List (Not Applicable)		
Section IV.	National Stock Number and Part Number Index	I-1	
APPENDIX E	ILLUSTRATED LIST OF MANUFACTURED ITEMS.	E-1	
Section I.	introduction	E-1	
Section II.	Manufactured Items illustrations	E-1	
INDEX		Index-1	

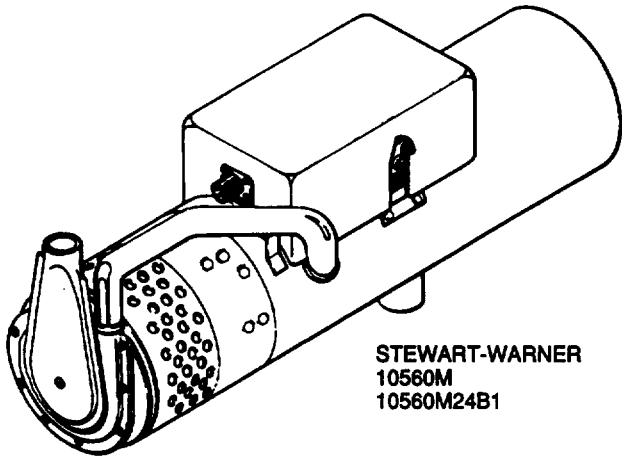

STEWART-WARNER
10560M
10560M24B1

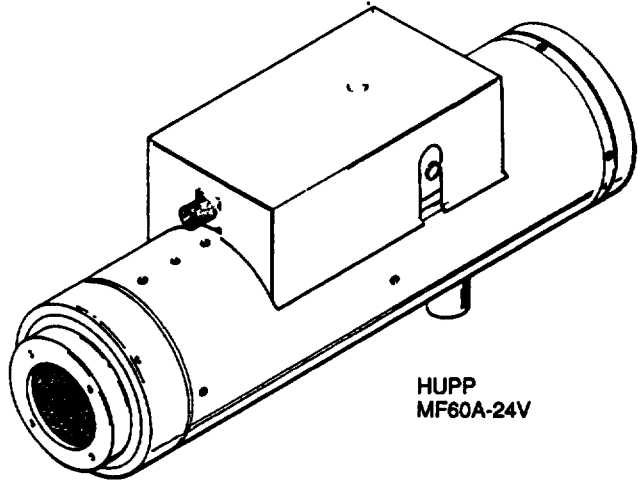

HUPP
MF60A-24V

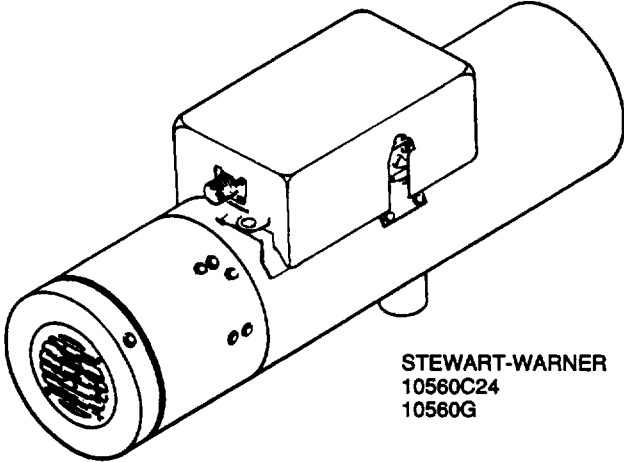

STEWART-WARNER
10560C24
10560G

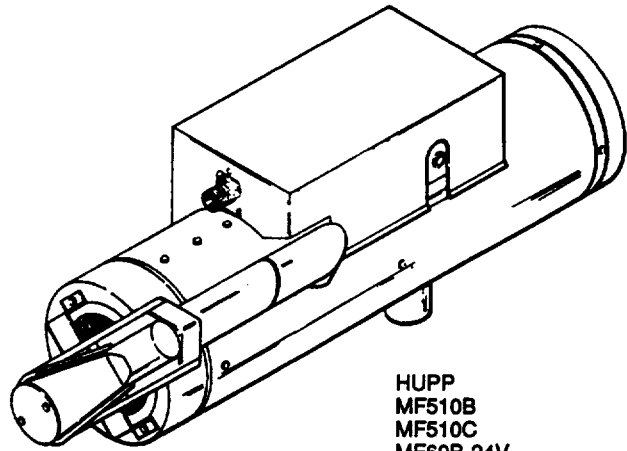

HUPP
MF510B
MF510C
MF60B-24V

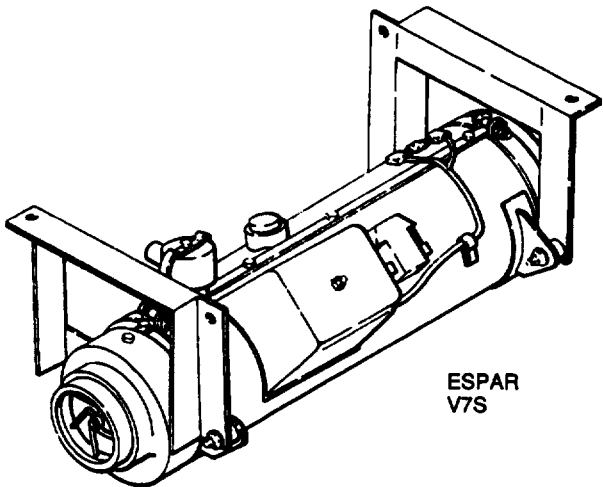

ESPAR
V7S

CHAPTER 1

INTRODUCTION

OVERVIEW

The purpose of this chapter is to tell you about the functions and features of the vehicular compartment heaters covered in this manual.

		Page
Section 1.	General Information	1-1
Section II.	Equipment Description and Data	1-2
Section III.	Principles of Operation	1-13

Section I. GENERAL INFORMATION

	Page		Page
Destruction of Army Materiel to Prevent Enemy Use	1-1	Reporting Equipment Improvement Recommendations (EIR's)	1-1
Maintenance Forms and Records	1-1	Scope	1-1

SCOPE

Type of Manual: Organizational, Direct Support, and General Support Maintenance (including Repair Parts and Special Tools Lists).

Model Number and Equipment Name: Stewart-Warner 10560G, 10560C24, 10560M) and 10560M24B1; Hupp, MF60A-24V, MF60B-24V, MF510B, and MF510C; and ESPAR Products V7S Vehicular Compartment Heaters.

Purpose of Equipment: Supplies warm air to the cab and cargo area for crew comfort and windshield defrosting.

MAINTENANCE FORMS AND RECORDS

Department of the Army forms and procedures used for equipment maintenance will be those prescribed by DA PAM 738-750, The Army Maintenance Management System (TAMMS).

DESTRUCTION OF ARMY MATERIEL TO PREVENT ENEMY USE

Refer to TM 750-244-6, Procedures for Destruction of Tank-Automotive Equipment to Prevent Enemy Use (US Army Tank-Automotive Command).

REPORTING EQUIPMENT IMPROVEMENT RECOMMENDATIONS (EIR'S)

If your personnel heater needs improvement, let us know. Send us an EIR. You, the user, are the only one who can tell us what you don't like about your equipment. Let us know why you don't like the design or performance. Put it on an SF 368 (Quality Deficiency Report). Mail it to us at: Commander, US Army Tank-Automotive Command, ATTN: AMSTA-MP, Warren, MI 48397-5000. We'll send you a reply.

Section II. EQUIPMENT DESCRIPTION AND DATA

	Page		Page
Differences Between Models	1-9	Location and Description of	
Equipment Characteristics,		Major Components	1-2
Capabilities, and Features	1-2	Location of Data Plates	1-7
Equipment Data	1-10		

EQUIPMENT CHARACTERISTICS, CAPABILITIES, AND FEATURES

Many different heaters have been used in combat vehicles. These heaters supply warm air for crew comfort. The heater is mounted in various locations based on model of vehicle application, and is operated by a control box in the cab or driver compartment. The control box allows the operator to turn the heater on and off and adjust the desired heat output. The control box is part of the vehicle; its operation and maintenance are not covered by this manual.

LOCATION AND DESCRIPTION OF MAJOR COMPONENTS

Hupp Models MF510B, MF510C, MF60A-74V, and MF60B-24V

FUEL SYSTEM

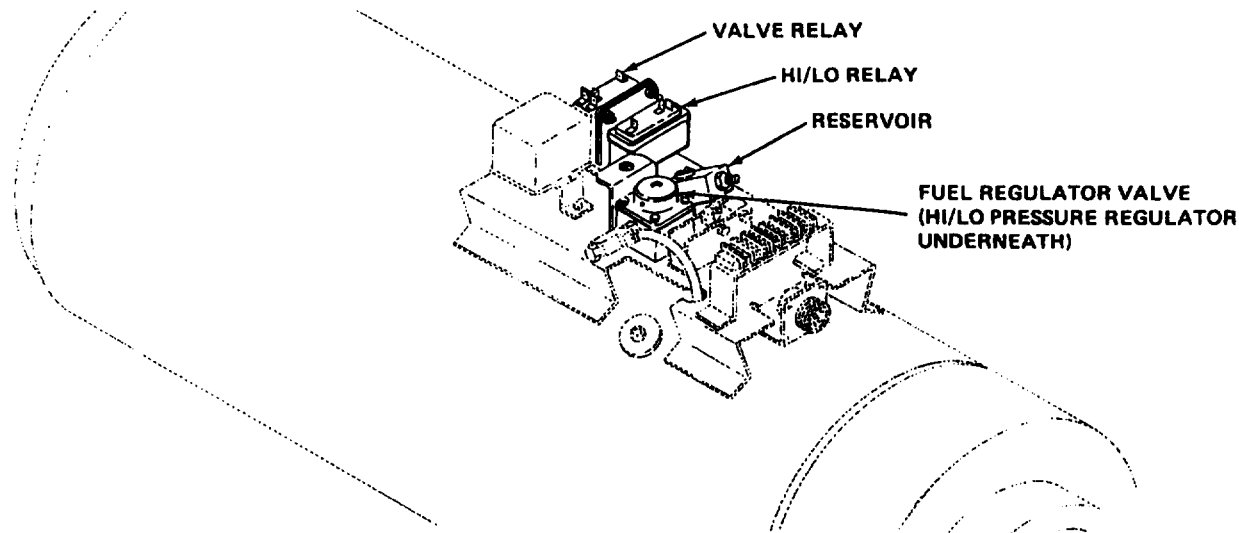

LOCATION AND DESCRIPTION OF MAJOR COMPONENTS- Continued

Hupp Models MF510B, MF510C, MF60A-24V, and MF60B-24V

IGNITION SYSTEM

IGNITION SYSTEM

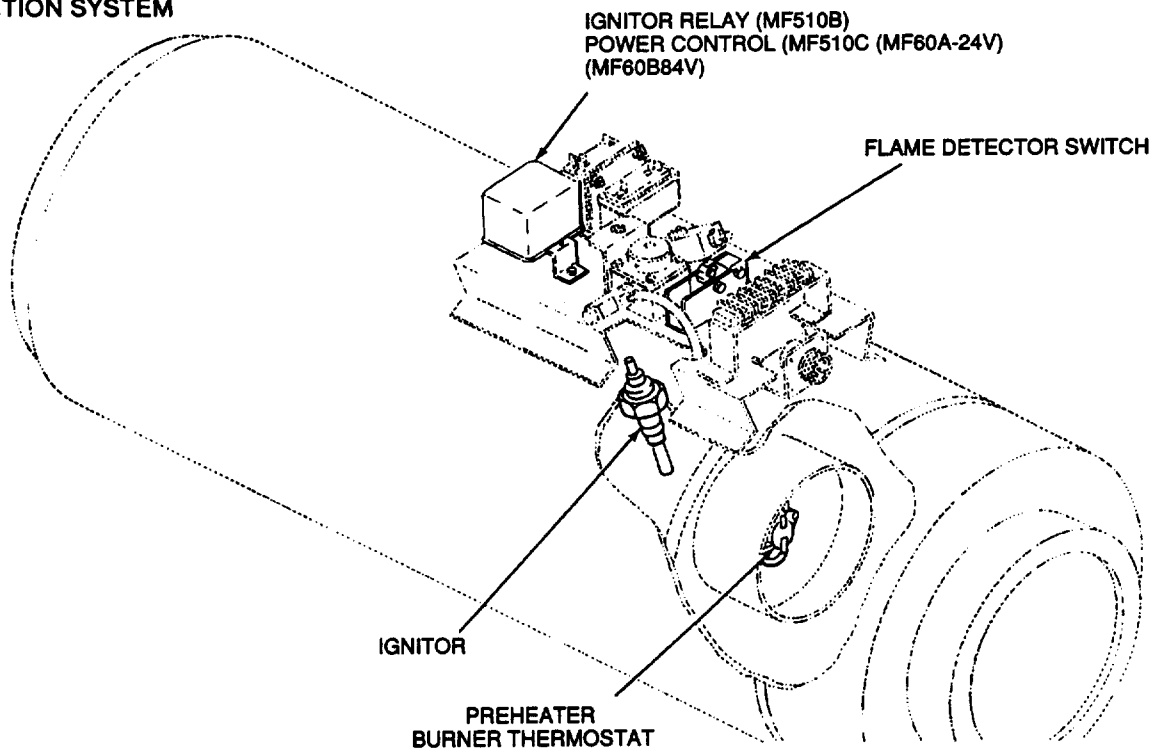

LOCATION AND DESCRIPTION OF MAJOR COMPONENTS - Continued

Hupp Models MF510B, AND MF510C

AIR FLOW SYSTEM

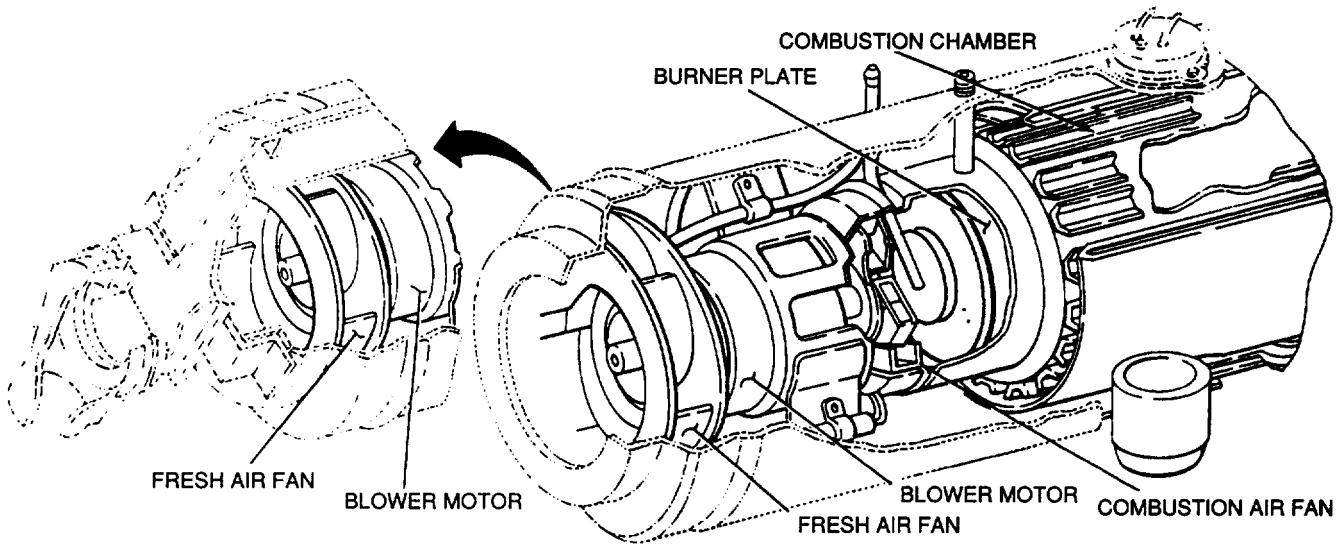

Stewart-Warner Models 10560C24, 10560M, and 10560M24B1, 10560G

NOTE

There may still be some 10560B heaters in the field. A conversion kit is available for converting "B" heaters into more reliable "C" models (see Appendix D for parts information). Additional information on conversion is available from U.S. Army Tank-Automotive Command, ATTN: AMSTA-MCC, Warren, MI 48397-5000.

FUEL SYSTEM

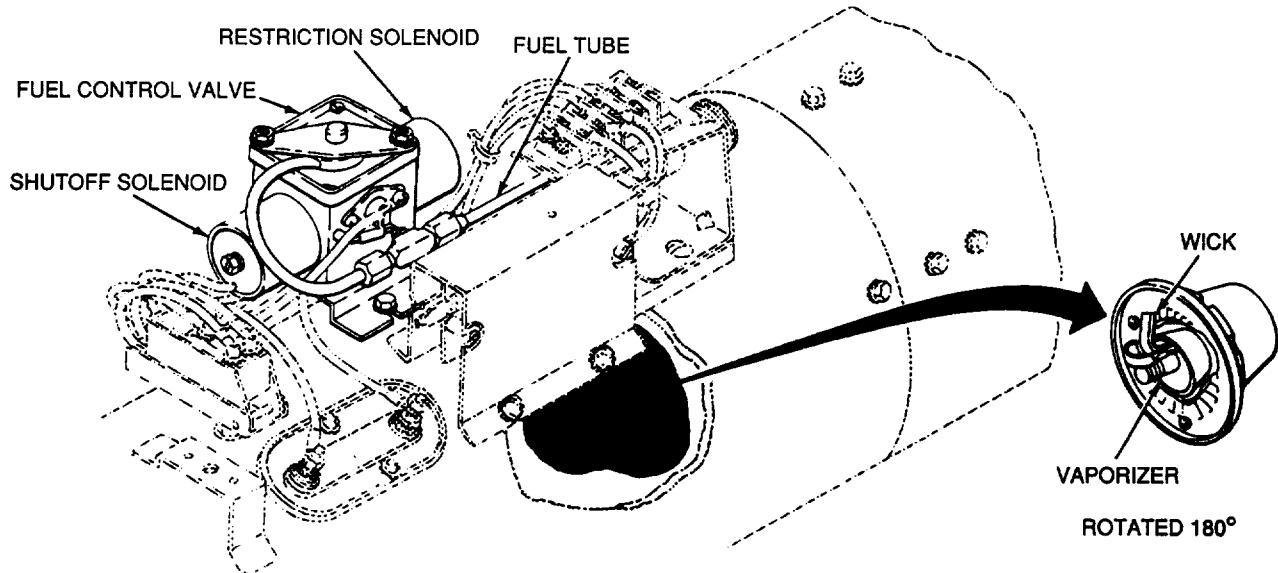

LOCATION AND DESCRIPTION OF MAJOR COMPONENTS-Continued

Stewart-Warner Models 10560C24, 10560M, and 10560M24B1, 10560G

IGNITION SYSTEM

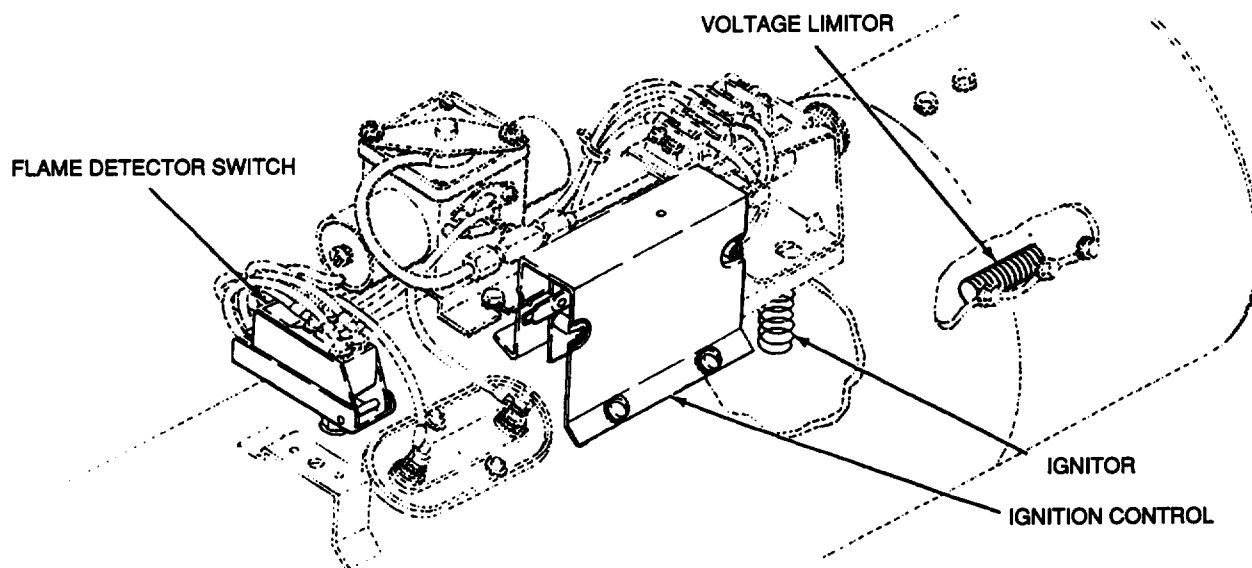

LOCATION OF MAJOR COMPONENTS - Continued

ESPAR Model V7S

FUEL SYSTEM

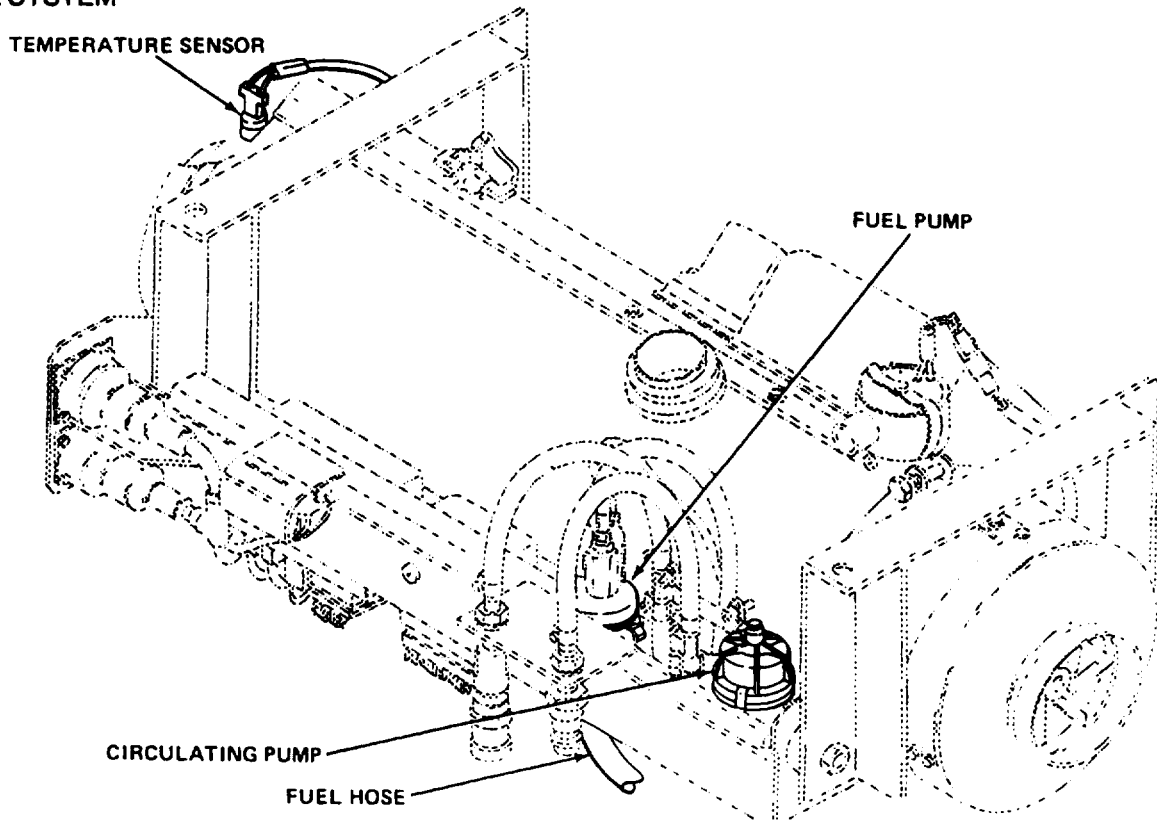

IGNITION SYSTEM

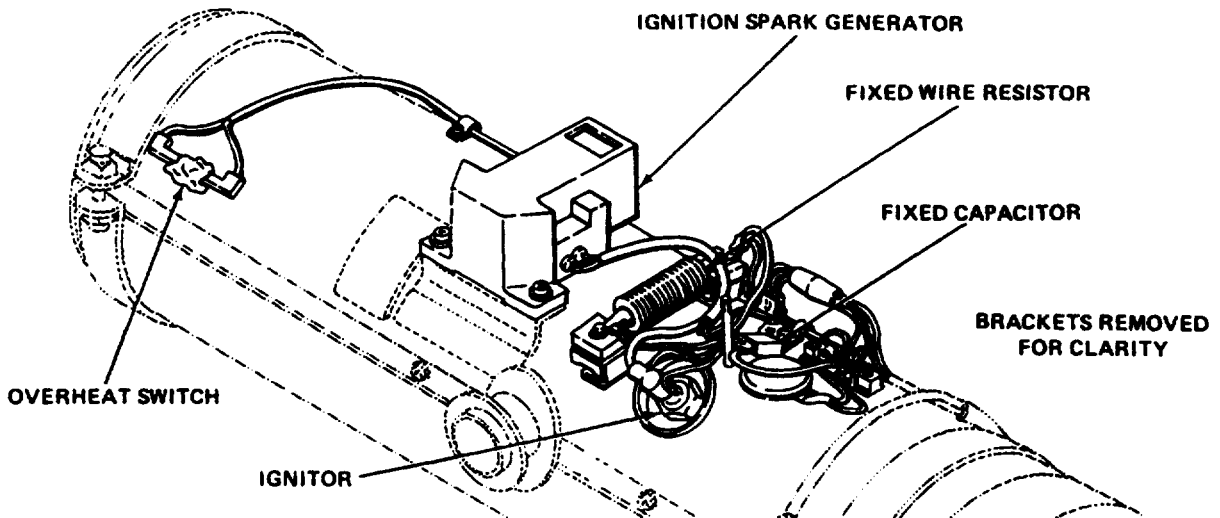

LOCATION AND DESCRIPTION OF MAJOR COMPONENTS - Continued

ESPAR Model V7S

AIR FLOW SYSTEM

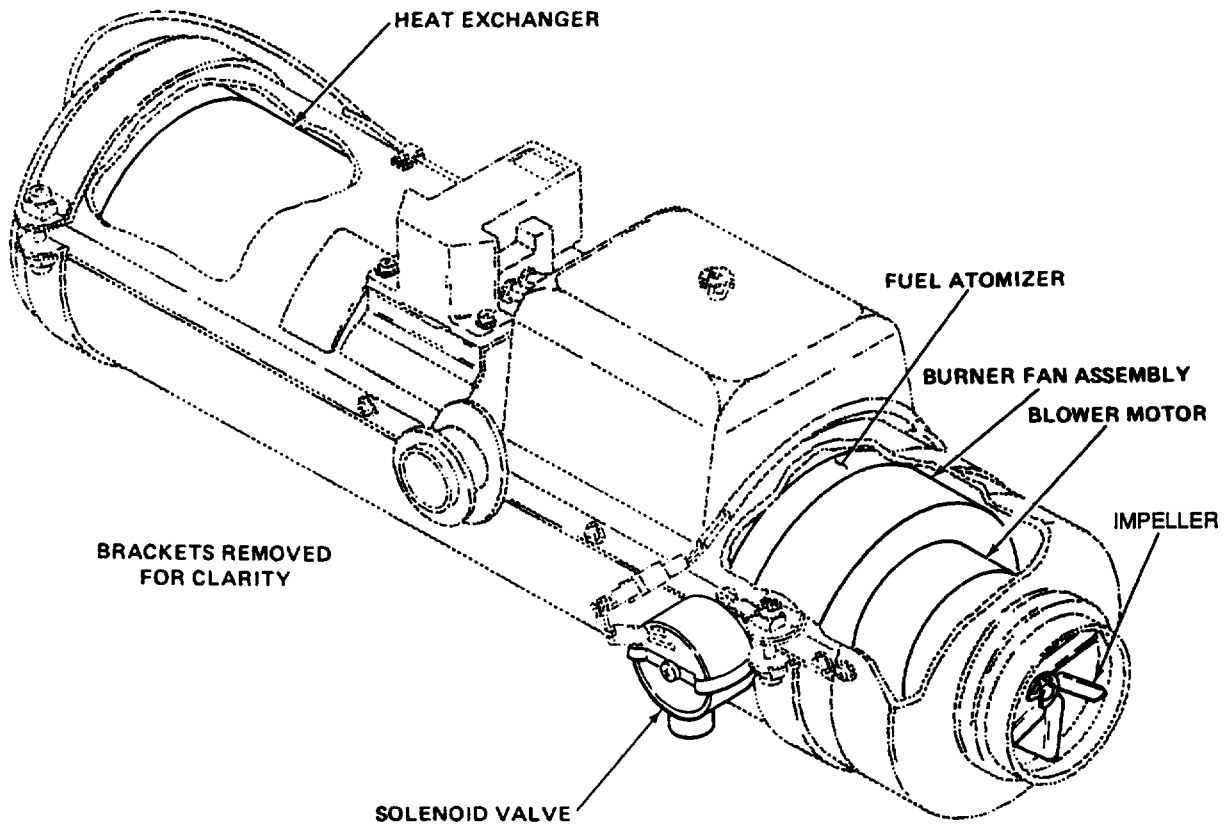

LOCATION OF DATA PLATES

Hupp Models MF51OB, MF51OC, MF60A-24V, and MF60B-24V

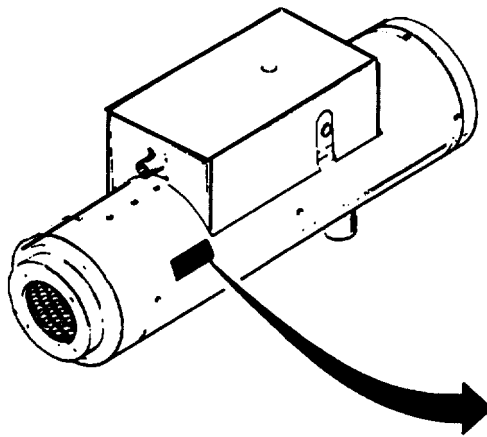



PERFECTION HEATER,		MODEL NO. <input type="text"/>	
PART NO. <input type="text"/>		SERIAL NO. <input type="text"/>	
CAPACITY - OUTPUT B.T.U./HR. <input type="text"/>		VOLTAGE <input type="text"/>	
<input type="text"/> ORD. NO. 1160809		PATS. PENDING	
MOBILE PRODUCTS DIV., CLEVELAND, OHIO 44110			
HUPP INC.		U.S.A.	
CONTRACT NO. <input type="text"/>		STOCK NO. <input type="text"/>	
SPECIFICATION <input type="text"/>		CLASS <input type="text"/>	
HEATER		COMBUSTION TYPE	
U.S. PROPERTY			

Stewart-Warner Models 1056OC24, 1056OM, 1056OM24B1, and 1056OG

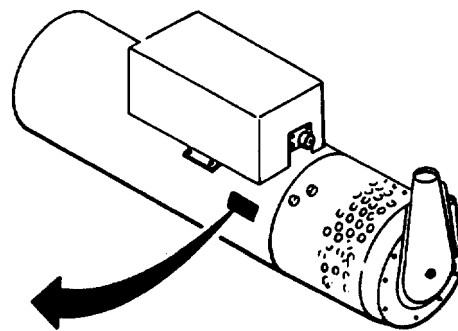
HEATER, VEHICULAR COMPARTMENT MUTIFUEL BURNING	
ARMY NO.	11689496
STOCK NO.	2540-01-083-0891
CONTRACT NO.	<input type="text"/> DAAE07-90-C-0103
SERIAL NO.	<input type="text"/> 18159 U S
VOLTS 14 AMPS - START - 17, RUN - 16	
INSTALL HEATER WITH NEGATIVE GROUND ONLY STEWART - WARNER CORPORATION	
MODEL 78385-10560 C-24 <input type="checkbox"/> 60,000 BTU/HR PATENT NO. 5 2,850,004-3, 168,899-3, 523,004 3,602,621 OTHER PATENTS PENDING	
SOUTH WIND DIVISION INDIANAPOLIS, INDIANA, USA	
705224	



LOCATION OF DATA PLATES- Continued

MADE IN W. GERMANY	
Heizgerät Typ	V7S
Ausführung	25124401
Fabrik Nr.	12088
Prüfzeichen	 S130
Brennstoff	Viostoff
Elektr. Werte	110W 24V
Wärmestrom	3000-12000W
Betriebsdruck	max - bar
Erste Inbetriebnahme	1982
19207 12300346	
	Hersteller J Eberspächer © Esslingen

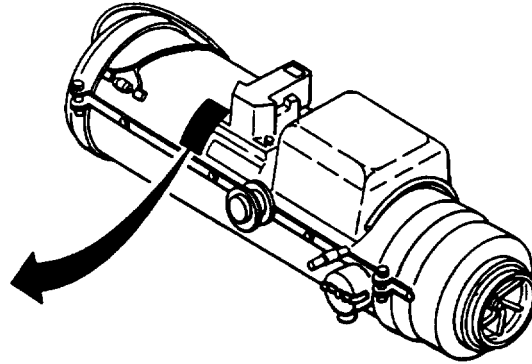

DIFFERENCES BETWEEN MODELS

The heater models make heat by burning a mixture of fuel and air, but different methods are used to deliver these to the combustion chambers. The following describes those differences:

HUPP MF510B, MF510C, MF60A-24V, MF60B-24V

The MF510B and MF510C use a single rubber hose to deliver fuel to the combustion chamber. Combustion and ventilation air for these heaters enter two separate inlets. The MF510B uses a 25-volt igniter with an electromechanical voltage regulator. The MF510C uses an 18-volt igniter with a transistorized power regulator. The MF60A-24V and MF60B-24V use a 19 to 30-volt igniter with a transistorized power regulator. The MF510C uses an 18-volt igniter with a transistorized power regulator.

STEWART-WARNER 10560C24, 10560G.

The 10560C24 and 10560G uses a single tube to deliver fuel to the combustion chamber. Fuel flow through the tube is doubled to increase heat output. Fuel flow begins as soon as the heater is turned on and continues until it is turned off. The 10560C24 has a single inlet for combustion and ventilation air. The 10560G uses a pulsed fuel metering valve controlled by a solid state pulse generator.

STEWART-WARNER 10560M

The 10560M is identical to the 10560C24 except that two inlets deliver air for combustion and ventilation.

STEWART-WARNER 10560M24B1 , 10560G

The 10560M24B1 and 10560G are identical to the 10560M except that they use a pulsed fuel metering valve controlled by a solid state pulse generator.

ESPAR V7S

The V7S has a single flexible hose for fuel delivery to the combustion chamber. Fuel flow through this hose is pulsed, and the pulse rate can be varied to adjust the heat output. Air is delivered to the V7S for combustion and ventilation through a common inlet.

EQUIPMENT DATA

Hupp Models, MF510B, and MF510C, MF60A-24V, MF60B-24V

HEAT OUTPUT

High heat (HI)	54,000 to 60,000 Btu/hour
Low heat (LO)	27,000 to 33,000 Btu/hour

TEMPERATURE RISE OVER SURROUNDING AIR
(measured at heater output)

High heat (HI)	250°F (120°C) minimum
Low heat (LO)	110°F (43°C) minimum

OVERHEAT SWITCH SETTING 325° to 475°F (163° to 246°C)

FUEL REQUIREMENTS

Type	Any hydrocarbon fuel ranging from DF1, DF2, JP8, and DFA. Fuel should conform to MIL-G-3056 (Type II, below 0°F) and/or Specification W-F-800
------	---

Temperature	Down to cloud point of fuel or -65°F (-54°C) when using DFA
-------------	---

Pressure at fuel inlet	3 to 15 psig (43.5-217.5 bars)
------------------------	--------------------------------

Consumption per minute
MF60A-24V, MF60B-24V

High heat (HI)	0.092 lbs (41.6 g)
Low heat (LO)	0.052 lbs (23.6 g)

MF510B, MF510C

High heat (HI)	0.085 lbs (38.6g) maximum
Low heat (LO)	0.047 lbs (21 .3g) maximum

ELECTRICAL REQUIREMENTS

Operating voltage	20.0 to 28.5 Vdc (24Vdc nominal)
-------------------	----------------------------------

Starting current

MF60A-24V, MF60B-24V

Above 30°F (-1°C)	16.0 amperes
Below 30°F (-1°C)	21.0 amperes

MF510B, MF510C

Above 30°F (-1°C)	16.0 amperes
Below 30°F (-1°C)	23.0 amperes

Running current

MF60A-24V, MF60B-24V

Above 30°F (-1°C)	15.0 amperes
Below 30°F (-1°C)	20.0 amperes

EQUIPMENT DATA - Continued**Hupp Models MF510B, and MF510C, MF60A24V, MF60B-24V -Continued****ELECTRICAL REQUIREMENTS - Continued**

Running Current - Continued

MF510B, MF510C

Above 30° F (-1°C)	15.0 amperes
Below 30°F (-1°C)	20.0 amperes

DIMENSIONS

MF60A-24V, MF60B-24V

Length	24.125 inches (61.3 cm)
Width	8 inches (20.3 cm).
Height	11 inches (27.9 cm)

MF510B, MF510C

Length	27.125 inches (68.9 cm)
Width	8 inches (20.3 cm).
Height	11 inches (27.9 cm)

WEIGHT

MF510B, MF510C, MF60A-24V, MF60B-24V 32 lbs(14.5 kg)

Stewart-Warner Models 10560C24, 10560M, 10560M24B1, and 10560G**HEAT OUTPUT**

High heat (HI)	60,000 Btu/hr nominal
Low heat (LO)	30,000 Btu/hr nominal

OVERHEAT SWITCH SETTING

325 to 475°F (163 to 246°C)

FUEL REQUIREMENTS

Type	DF2, DFA, JP4, JP5, JP8
Pressure	3 to 15 psig (43.5 to 217.5 bars)
Consumption per minute	
High heat (HI)	0.075 to 0.085 lbs (34.0 to 38.6g)
Low heat (LO)	0.041 to 0.047 lbs (18.6 to 21.3g)

TEMPERATURE RISE OVER SURROUNDING AIR
(measured at heater output)

High heat (HI)	250°F (120°C) minimum
Low heat (LO)	110°F (43°C) minimum

ELECTRICAL REQUIREMENTS

Operating voltage	20.0 to 28.5 Vdc (24Vdc nominal)
Starting current	
10560C24, 10560G	
Above 45°F (7°C)	13 amperes
Below 45°F (7°C)	17 amperes
10560M, 10560M24B1	
Above 45°F (7°C)	15 amperes
Below 45°F (7°C)	20 amperes

EQUIPMENT DATA - Continued

Stewart-Warner Models 10560C24, 10560M, 10560M24B1, and 10560G - Continued

ELECTRICAL REQUIREMENTS - Continued

Running current	
10560C24, 10560G	
Above 45°F (7°C)	10 amperes
Below 45°F (7°C)	16 amperes
1056M, 10560M24B1	
Above 45°F (7°C)	13 amperes
Below 45°F (7°C)	19 amperes

DIMENSIONS

Length	26.375 inches (67.0 cm)
Width	8 inches (20.3 cm)
Height	10.75 inches (27.3 cm)

WEIGHT

10560C24, 10560G	33lbs(14.85 kg)
10560M, 10560M24B1	35 lbs (15.75 kg)

ESPAR Model V7S

HEAT OUTPUT

Maximum	36,855 to 45,045 Btu/hour
Minimum	9,180 to 11,220 Btu/hour

TEMPERATURE RISE OVER SURROUNDING AIR

(measured at heater outlet)	200°F \dot{V} 173 CFM
	(110°C \dot{V} 360 kg/hr)

OVERHEAT SWITCH SETTING

356°F (180°C)

FUEL REQUIREMENTS

Type	DF1, DF2, DFA, JP4, JP5, Kerosene
Temperature	Down to cloud point of fuel or -65°F (-54° when using DFA)
Consumption per minute	
Maximum heat output	0.041 lbs (18.6g)
Minimum heat output	0.014 lbs (6.2g)

ELECTRICAL REQUIREMENTS

Operating voltage	20.0 to 28.5 Vdc (24 Vdc nominal)
Starting current	17.5 amperes
Running current	4.6 amperes

DIMENSIONS

Length	25.625 inches (65.0 cm)
Width	9.875 inches (25.0 cm)
Height	12.2 inches (31.0 cm)

WEIGHT

46.2 lbs (21 kg)

Section III. PRINCIPLES OF OPERATION

	Page		Page
Basic Heater Operation	1-13	Stewart-Warner 10560C24, 10560G . . .	1-15
Espar V7S	1-22	Stewart-Warner 10560M,	
Hupp Models.	1-19	10560M24B1	1-14

BASIC HEATER OPERATION

The personnel heater produces heat by burning fuel. You need three things to make the heater work.

- o Fuel for burning
- o Away to light the fuel
- o A supply of air to mix with the fuel

To see how these three things are brought together in the heater, see the flow diagram below.

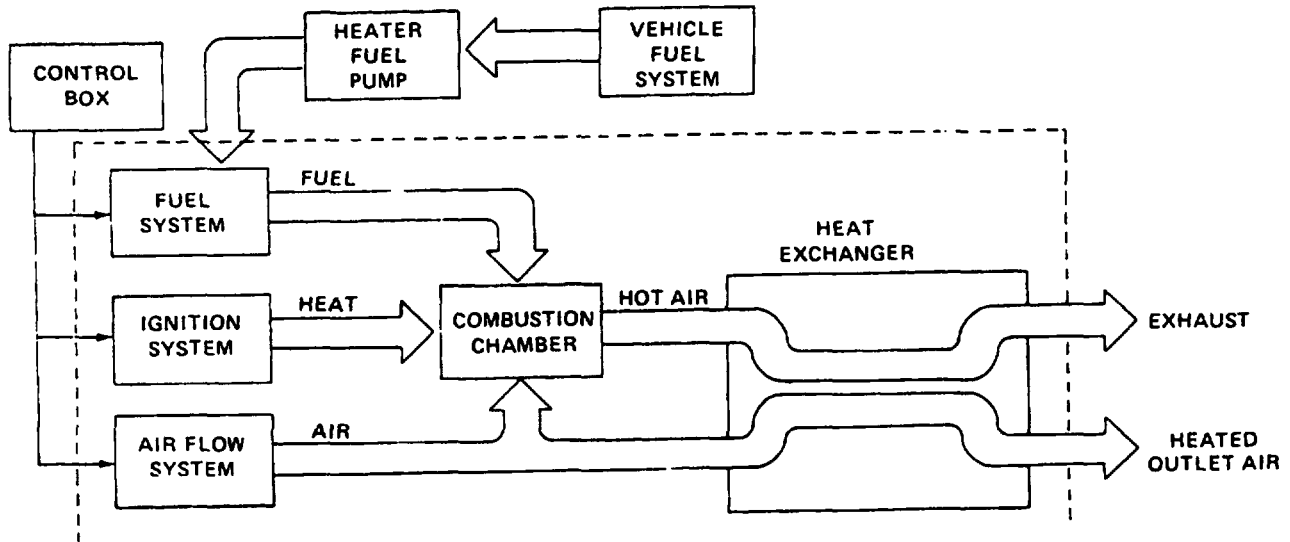

- o The fuel system controls fuel flow into the combustion chamber.
- o The ignition system lights the fuel.
- o The airflow system sends air into the combustion chamber for burning.

After combustion, the heater works like this:

- o The hot air from the combustion chamber goes through the heat exchanger.
- o The heat exchanger transfers the heat to fresh air supplied by the airflow system.
- o The heated fresh air is sent through the vehicle ductwork.
- o The exhaust gases are sent outside the vehicle.

AIR FLOW SYSTEM

Stewart-Warner 10560M, 10560M24B1

BLOWER MOTOR-Turns the blower wheels to provide air to the heater. During the start cycle, it runs at a reduced speed. This results in a richer fuel/air mixture that lights easier (same as 1056C24).

VENTILATION BLOWER WHEEL-Forces air through the heater, around the heat exchanger, and out to the vehicle ductwork (same as 10560C24).

COMBUSTION BLOWER WHEEL-Draws air from outside vehicle and forces it through duct and into combustion chamber.

COMBUSTION CHAMBER-Place where fuel, airflow, and ignition systems come together, and burning occurs. Hot gases are forced into heat exchanger.

HEAT EXCHANGER-Provides a large surface area for heat transfer to take place between combustion gases and ventilation air. The hot gases are forced out exhaust port and piped out of vehicle.

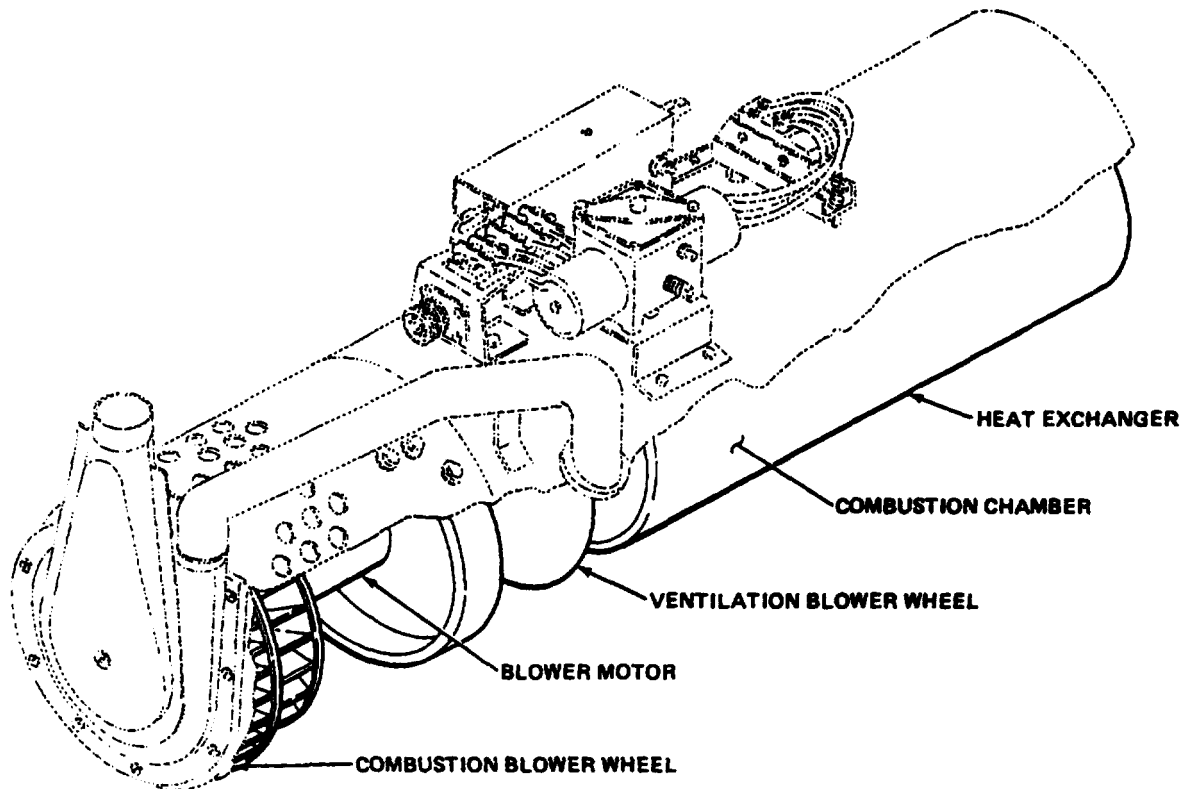

AIR FLOW SYSTEM

Stewart-Warner and 10560C24, 10560G

BLOWER MOTOR-Turns the blower wheels to provide air to the heater. During the start cycle it runs at a reduced speed. This results in a richer fuel/air mixture that lights easier.

VENTILATION BLOWER WHEEL-Forces air through the heater, around the heat exchanger, and out to the vehicle ductwork.

COMBUSTION BLOWER WHEEL-Takes a portion of the air forced into the heater by the ventilation blower wheel and forces it into the combustion chamber.

COMBUSTION CHAMBER-Area where fuel, air flow, and ignition systems come together and burning occurs. Hot gases are forced into the heat exchanger.

HEAT EXCHANGER-Provides a large surface area for heat transfer to take place between combustion gases and ventilation air. The hot gases are forced out the exhaust port and piped out of the vehicle.

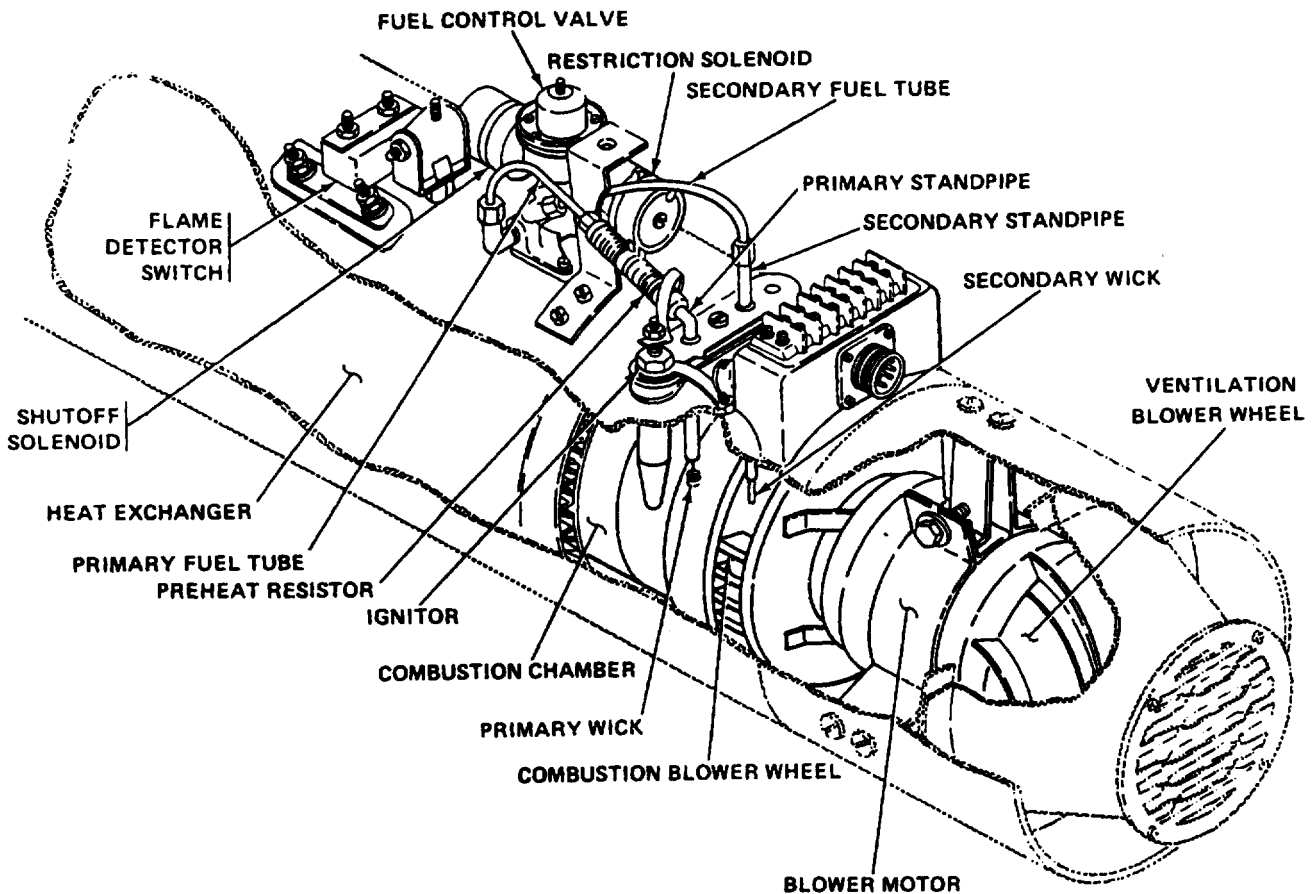

FUEL SYSTEM

Stewart-Warner 10560C24, 10560G

FUEL CONTROL VALVE-Controls pressure, temperature, and delivery of Incoming fuel. Pressure is regulated by a needle valve and diaphragm. Fuel is heated by an electric heater, and fuel temperature is monitored by a snap-action thermostat. Fuel leaving the valve is metered by passing through a calibrated orifice.

SHUT-OFF SOLENOID-Turns fuel flow on and off. Controlled by RUN/OFF/START on control box.

RESTRICTION SOLENOID-Allows more fuel to be delivered to heater. Controlled by HI/LO switch on control box.

CAUTION

Do not start in HI mode, may cause flood out.

FUEL TUBE-Rigid tube used to deliver fuel to heater.

BYPASS TUBE-Equalizes pressure on both sides of diaphragm in fuel control valve. Permits proper heater operation in any position.

VAPORIZER-Spreads fuel over a larger surface area for better mixing with air before burning.

WICK-Presents fuel/air mixture to igniter for lighting.

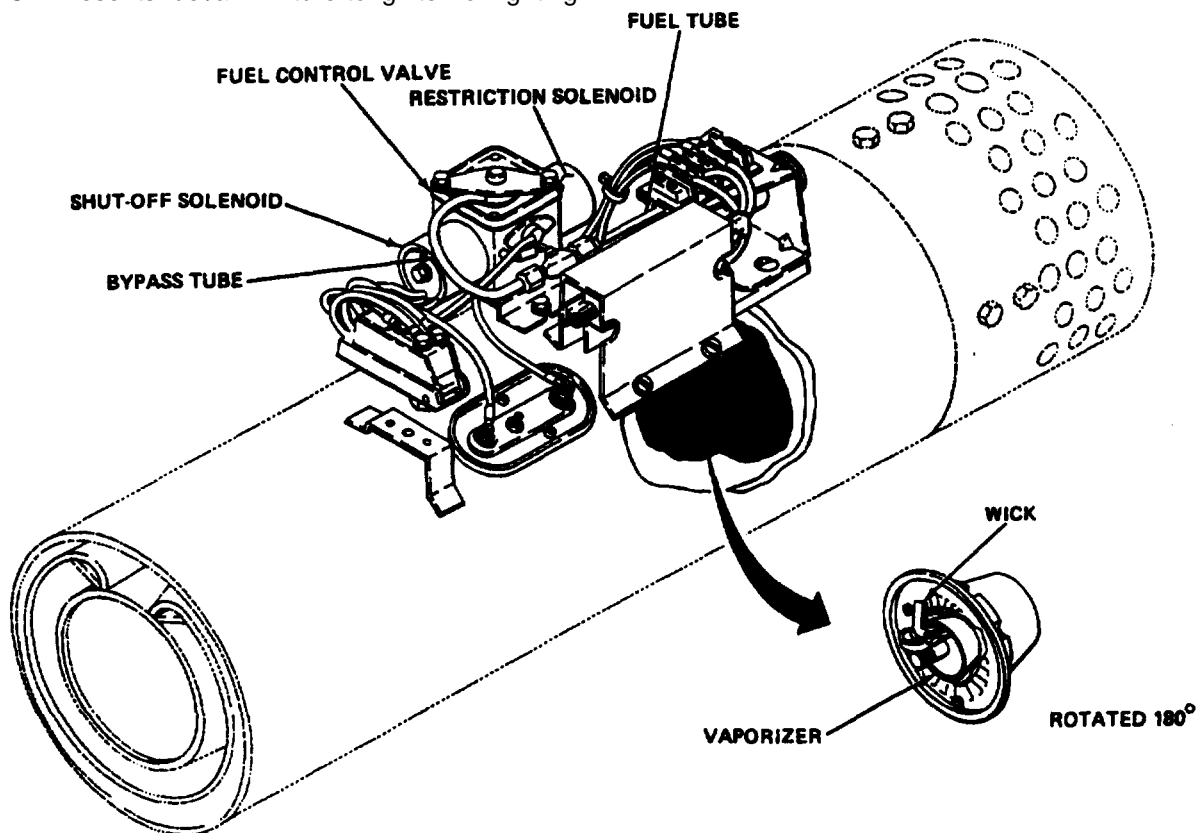

FUEL SYSTEM

Stewart-Warner 10560M24B1, 10560M

PULSED FUEL METERING VALVE-Controls pressure, temperature, and delivery of incoming fuel. Pressure is regulated by a needle valve and diaphragm. Fuel is heated by an electronic heater, and fuel temperature is monitored by a snap-action thermostat. Fuel is metered by passing through a calibrated orifice.

Rate of fuel flow through fuel metering valve is determined by the number of pulses generated for a specific period by the pulse generator. These pulses are sent to the solenoid plunger, causing it to open and allowing the fuel to flow.

SOLENOID-Turns fuel flow on and off. Controlled by pulse generator.

PULSE GENERATOR-Determines operating frequency of solenoid. Adjustable for both HI and LO heat operation. Controlled by switch settings on control box.

FUEL TUBE-Rigid tube used to deliver fuel to heater.

VAPORIZER-Spreads fuel over a large surface area for better mixing with air before burning.

WICK-Presents fuel/air mixture to igniter for lighting.

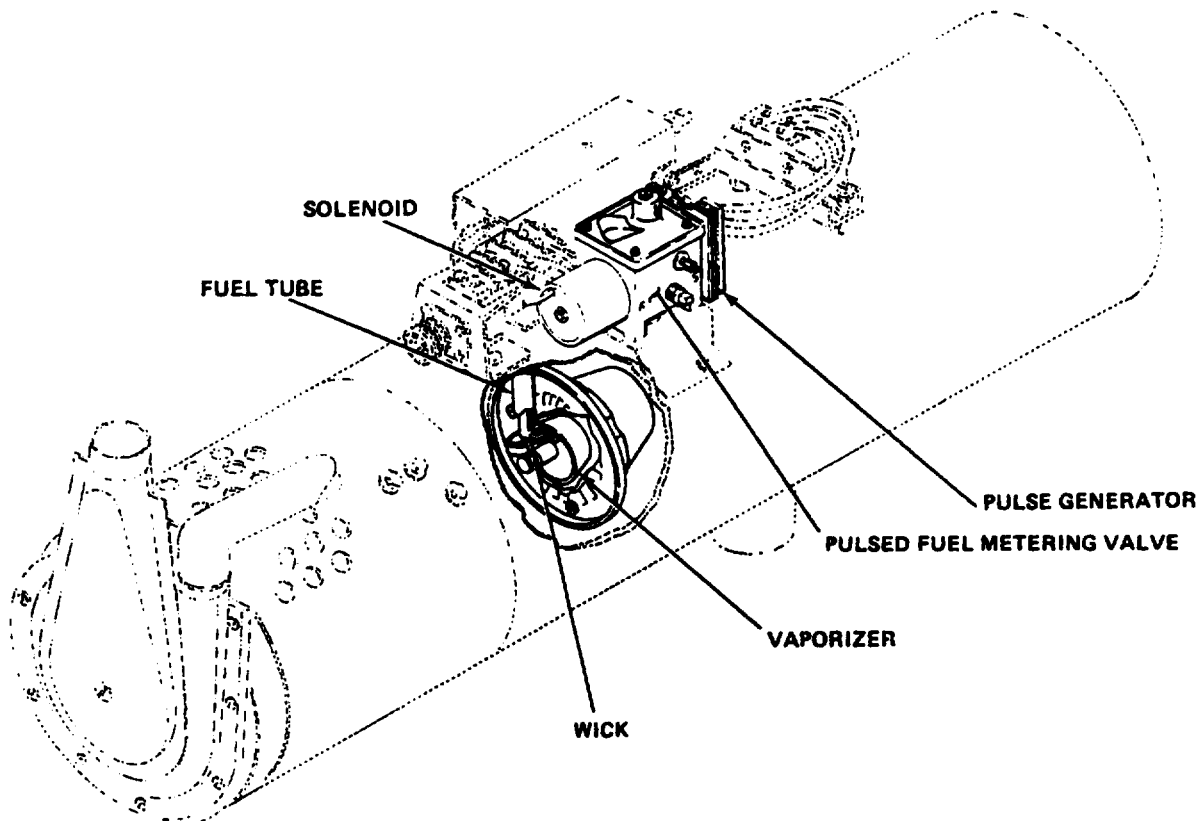

IGNITION SYSTEM

Stewart-Warner 10560C24, 10560M, 10560M24B1, 10560G

IGNITION CONTROL-Limits igniter current.

VOLTAGE LIMITER-Clamps igniter voltage to a safe level.

IGNITOR-Provides heat for lighting fuel/air mixture by glowing red-hot when energized.

FLAME DETECTOR SWITCH-Turns off ignition system once heater has started. It also connects the blower motor directly to the +24-volt supply so it runs at full speed. It consists of a transfer-type microswitch operated by a ceramic rod in a closed metal tube. Heat expands the tube, moving the rod away from the switch. When the rod moves far enough, the switch operates.

DIODE-Separates start circuit from the motor circuit. It stops the current from entering the start circuit when heater is running.

CAUTION

A properly adjusted flame detector switch can prolong igniter life. Misadjustment can cause a burned-out igniter or a heater that will not start. Information on required adjustments is contained in the individual heater component paragraphs, referenced on page 2-39 (Section VI. Organizational Maintenance Procedures).

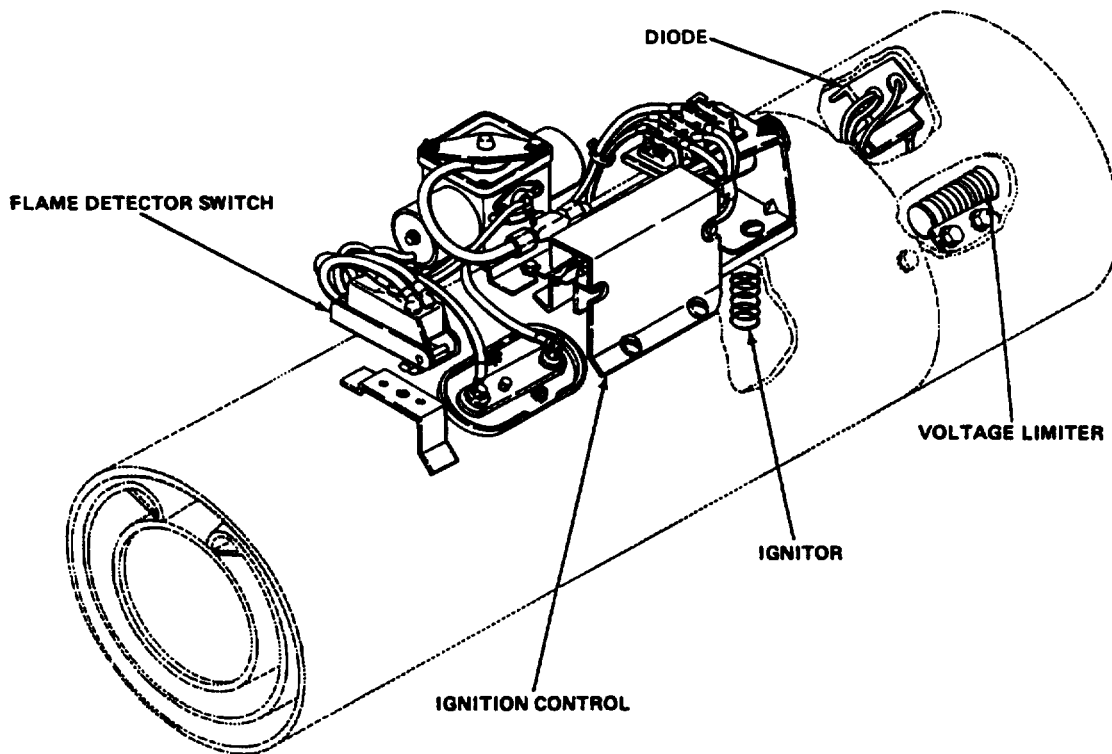

FUEL SYSTEM

Hupp MF510B, MF510C, MF60A-24V, MF60B-24V

RESERVOIR-Retains and heats incoming fuel during preheat cycle. Once heater is preheated, fuel passes through reservoir into fuel regulator valve.

FUEL REGULATOR VALVE-Controls pressure, temperature, and delivery of incoming fuel. Pressure is regulated by a needle valve. Fuel is heated by two heating elements controlled by a thermostat on the reservoir. The fuel is metered by passing through a calibrated nozzle at the output of the valve.

HI/LO PRESSURE REGULATOR-Allows more fuel to be delivered to heater. Similar to restriction solenoid on Stewart-Warner heaters. Controlled by HI/LO fire relay.

VALVE RELAY-Controls shut-off solenoid operation. Overrides burner thermostat, and remains energized until turned off at the control box.

HI/LO FIRE RELAY-Operates HI/LO pressure regulator. Controlled by HI//LO switch on control box.

FUEL HOSE AND FUEL TUBE-Flexible hose and rigid tube used to deliver fuel to heater.

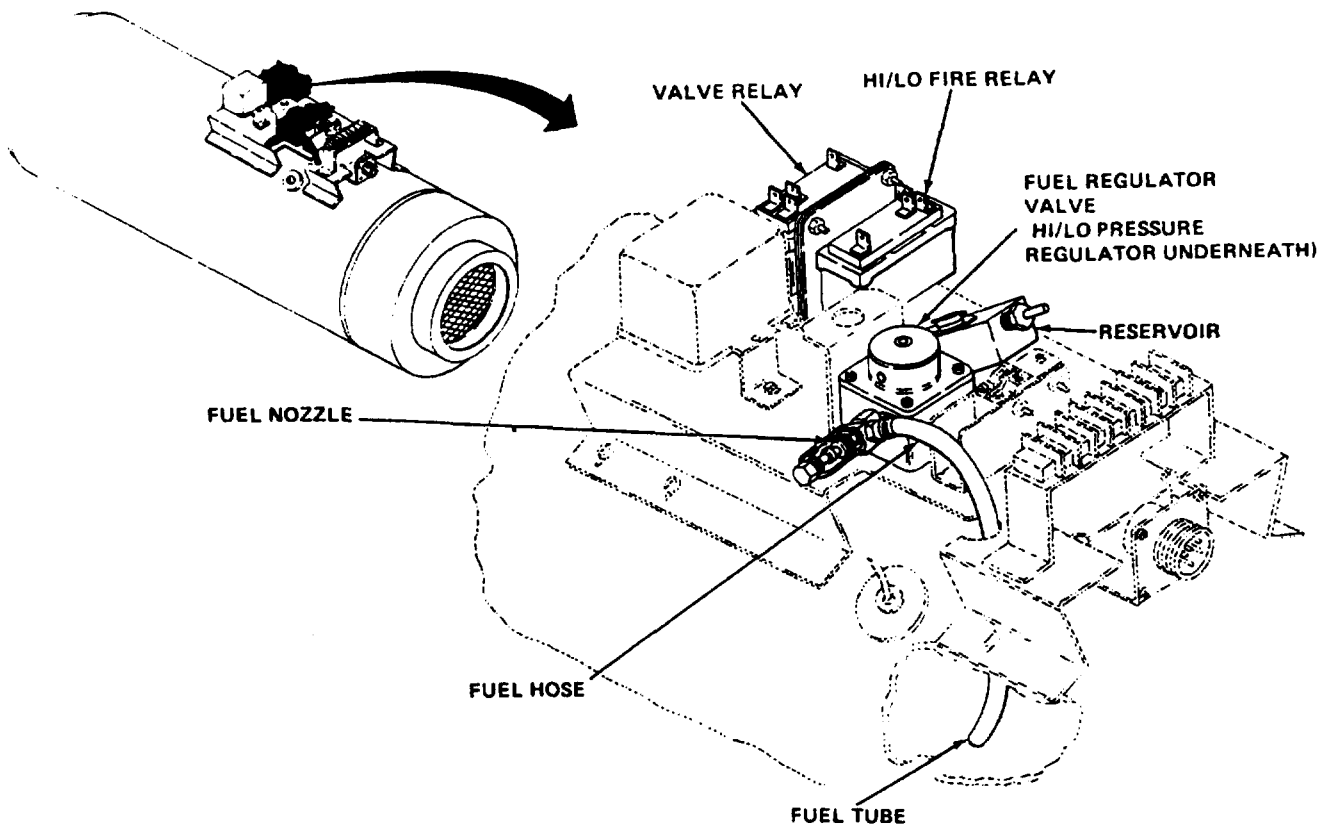

IGNITION SYSTEM

Hupp MF510B, MF510C, MF60A-24V, MF60B-24V

IGNITOR RELAY (MF510B)-Monitors ignitor voltage, and adds a dropping resistor to the circuit if voltage exceeds 25 volts. It is an electromechanical device that extends igniter life.

POWER CONTROL (MF510C, MF60A-24V, MF60B-24V)-A transistorized device that clamps the ignitor voltage to a safe level.

IGNITOR-Provides heat for lighting fuel/air mixture by glowing red-hot when energized.

PREHEATER-Warms the burner plate until it reaches the proper temperature for ignition to occur.

BURNER THERMOSTAT-Signals the valve relay to turn on the fuel regulator valve. Starts fuel flow as soon as burner has reached proper temperature.

FLAME DETECTOR SWITCH-Turns off ignitor system once heater has started. It also connects the blower motor directly to the 24-volt supply so it runs at full speed. It consists of a transfer-type microswitch operated by a ceramic rod in a closed metal tube. Heat expands the tube, moving the rod away from the switch. When the rod moves far enough, the switch operates.

CAUTION

A properly adjusted flame detector switch can prolong igniter life. Misadjustment can cause a burned-out igniter or a heater that will not start. Information on required adjustments is contained in the individual heater component paragraphs, referenced on page 2-39 (section VI. Organizational Maintenance Procedures).

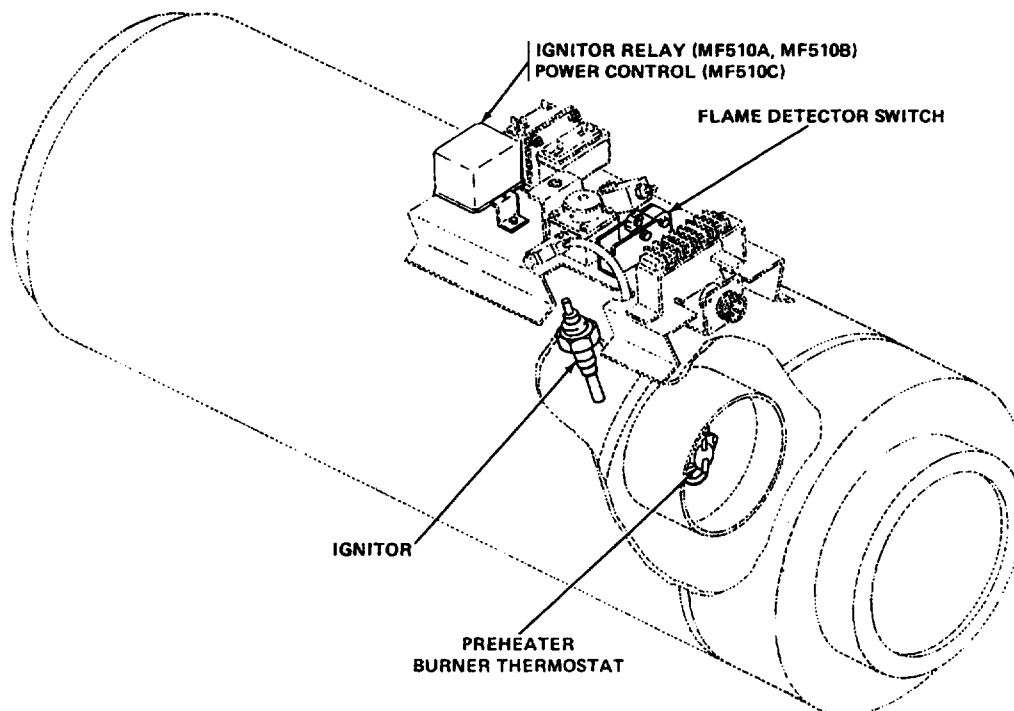

AIR FLOW SYSTEM

Hupp MF510B, MF510C, MF60A-24V, MF60B-24V

BLOWER MOTOR-Turns fans to provide air to heater.

FRESH AIR FAN-Forces air through heater around combustion chamber, and out to vehicle ductwork.

COMBUSTION AIR FAN-Draws air from outside vehicle through intake duct assembly and forces it past burner plate.

BURNER PLATE-Area where fuel, airflow, and ignition systems come together and burning occurs. Flames generated are forced into combustion chamber.

COMBUSTION CHAMBER-Area where heat is transferred from combustion gases inside to fresh air outside. The hot gases inside are forced out exhaust port and piped out of vehicle.

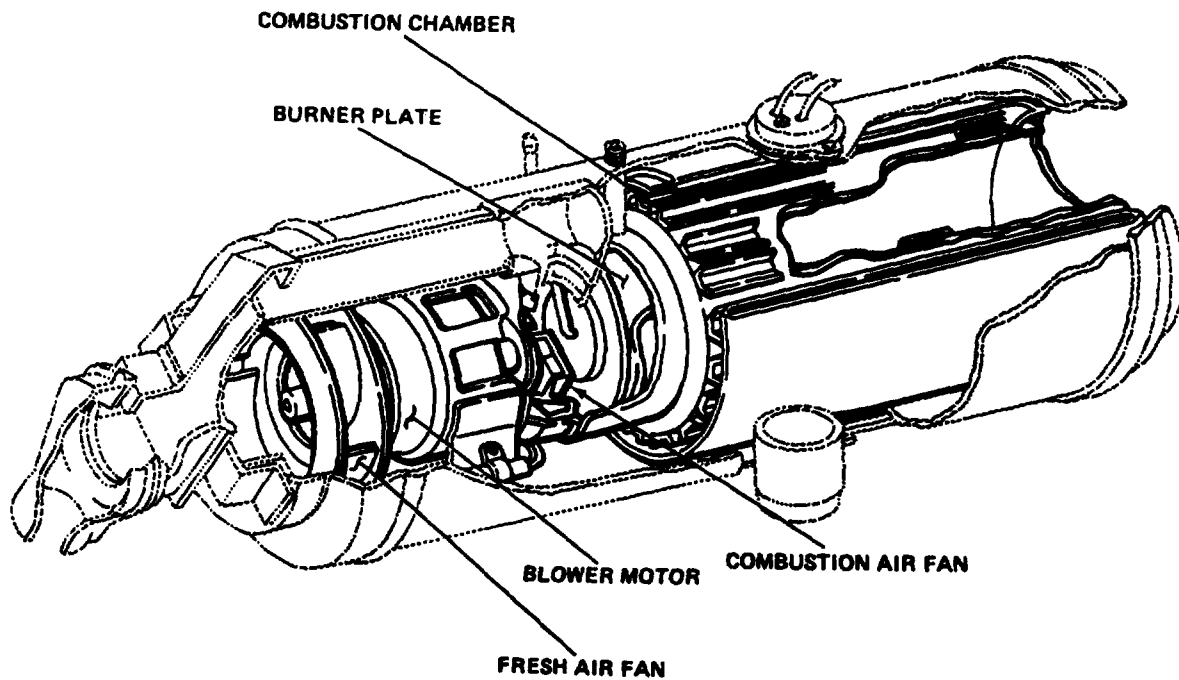

FUEL SYSTEM

ESPAR V7S

CIRCULATING PUMP-Regulates pressure of Incoming fuel.

FUEL PUMP-Meters fuel delivery into heater.

FUEL HOSE-Flexible hose used to deliver fuel to heater.

TEMPERATURE SENSOR-A temperature-sensitive resistor used to monitor heater output. Its resistance and resistance of heat regulator on control box are used by impulse switch to determine operating frequency of circulating pump.

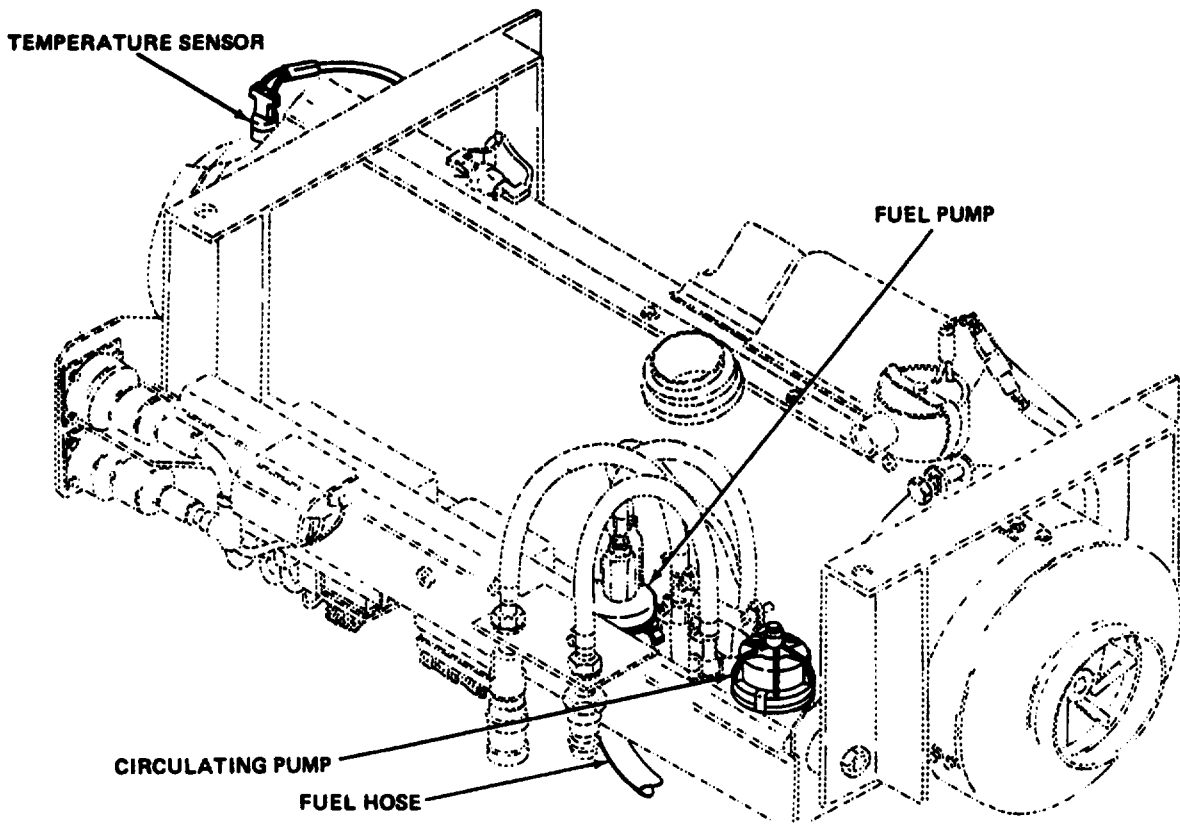

IGNITION SYSTEM

ESPAR V7S

IGNITION SPARK GENERATOR-Provides power to operate Igniter, Also turns on ignitor during periods of low frame to prevent flooding.

FIXED WIRE RESISTOR-Limits current applied to igniter.

IGNITOR-Provides heat for lighting fuel/air mixture by glowing red-hot when operated.

FIXED CAPACITOR-Prevents any radio frequency interference that maybe caused by ignition system.

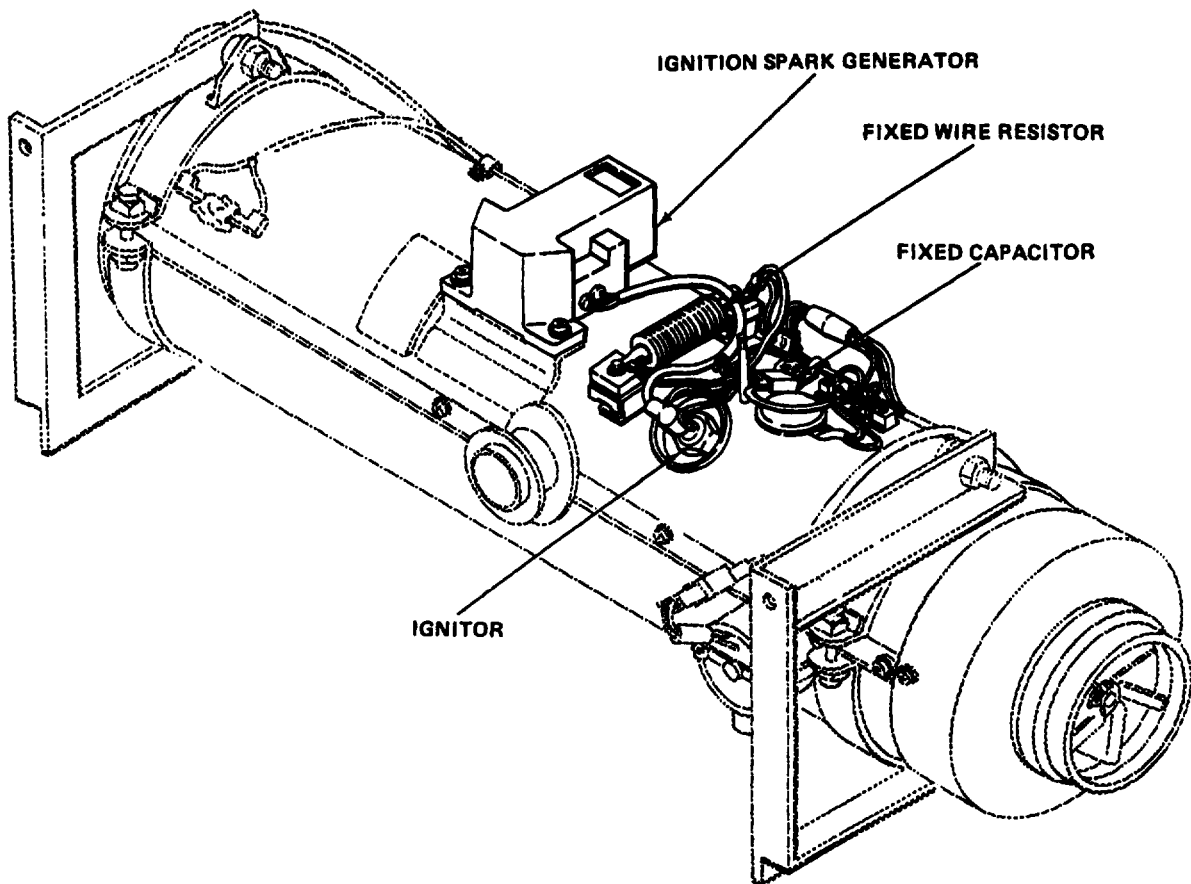

AIR FLOW SYSTEM

ESPAR V7S

BLOWER MOTOR-Turns impeller, combustion fan assembly, and fuel atomizer.

IMPELLER-Forces air through heater, around heat exchanger, and out to vehicle ductwork.

BURNER FAN ASSEMBLY-Draws air from outside vehicle and forces it through fuel atomizer.

FUEL ATOMIZER-Combines fuel and combustion air and creates a fine mist.

HEAT EXCHANGER-Place where fuel mist is burned and heat is transferred from hot gases inside to fresh air outside. Hot gases outside are forced out exhaust port and piped out of vehicle.

SOLENOID VALVE-Regulates amount of air drawn in by combustion fan assembly to control fuel/air mix ratio.

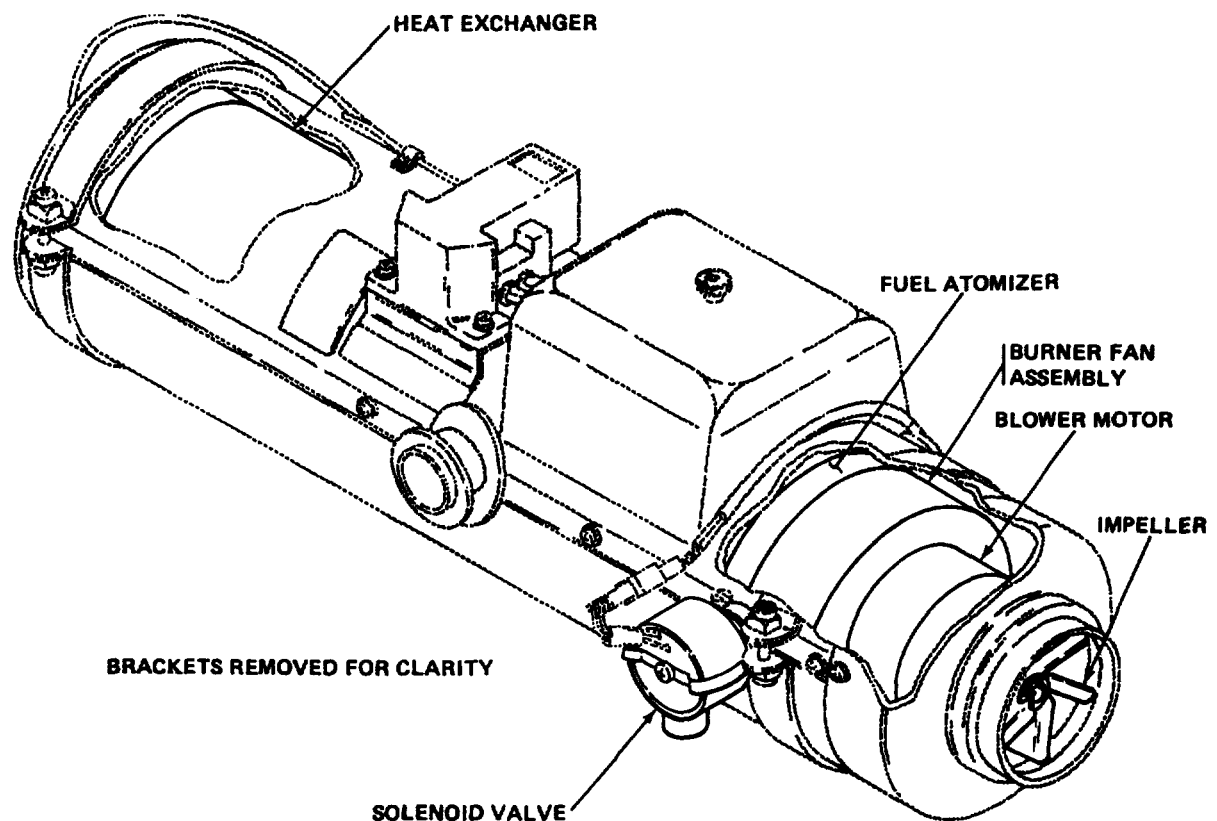

**CHAPTER 2
ORGANIZATIONAL MAINTENANCE**

OVERVIEW

This chapter provides procedures for heater troubleshooting and maintenance. All parts authorized for maintenance at the organizational level are covered. This chapter also covers the tools and equipment required for Organizational Maintenance.

		Page
Section 1.	General Maintenance Instructions	2-1
Section II.	Repair Parts, Special Tools; Test, Measurements and Diagnostic Equipment (TMDE); and Support Equipment	2-5
Section III.	Service Upon Receipt	2-5
Section IV.	Organizational Preventive Maintenance Checks and Services (PMCS)	2-6
Section V.	Organizational Troubleshooting Procedures	2-15
Section VI.	Organizational Maintenance Procedures	2-31
Section VII.	Start-Up and Shut-Down Procedures	2-59

Section 1. GENERAL MAINTENANCE INSTRUCTIONS

	Page		Page
Cleaning Instructions.	2-2	Scope	2-1
General Information	2-2	Tagging Wires and Hoses	2-3
Inspection Instructions	2-3	Electrical Tiedown Straps	2-1
Repair Instructions	2-4	Work Safety	2-1

SCOPE

These General Maintenance Instructions contain general shop practices and specific methods you must be familiar with to properly maintain the heaters. You should read and understand these practices and methods before starting tasks on the heaters.

WORK SAFETY

Before starting a task, think about the risks and hazards to your safety as well as others. Wear protective gear such as protective goggles or lenses, safety shoes, rubber apron, or gloves. Protect yourself against injury.

Observe all WARNINGS and CAUTIONS.

ELECTRICAL TIEDOWN STRAPS

Electrical tiedown straps, whether plastic or other material, shall be removed and replaced as needed by any appropriate method.

GENERAL INFORMATION

Before beginning a task, find out how much repair, conversion, or replacement is needed to fix the equipment as described in this manual. Sometimes the reason for equipment failure can be seen right away, and complete teardown is not necessary. Disassemble equipment only as far as necessary to repair or replace damaged or broken parts.

All tags and forms attached to the equipment must be checked to learn the reason for removal from service. Also, check all Modification Work Orders (MWO) and Technical Bulletins (TB) for equipment changes and updates.

In some cases, a part may be damaged by removal. If the part appears to be good, and other parts behind it are not defective, leave it on and continue the procedure.

Replace all gaskets, seals, and packings.

CLEANING INSTRUCTIONS

GENERAL

- a. The cleaning instructions will be the same for the majority of parts and components which make up the heaters.
- b. The importance of cleaning must be thoroughly understood by maintenance personnel. Great care and effort are required in cleaning. Dirt and foreign material are a constant threat to satisfactory maintenance. The following should apply to all cleaning, inspection, repair, and assembly operations:

CAUTION

Washing electrical cables and flexible hoses with drycleaning solvents or mineral spirits will cause serious damage or destroy the material.

NOTE

Wash electrical cables and flexible hoses with water and mild soap solution, and wipe dry.

1. Clean all parts before inspection, after repair, and before assembly.
2. Hands should be kept free of any accumulation of grease, which can collect dust, dirt, or grit.
3. After cleaning, all parts should be covered or wrapped to protect them from dust and dirt. Parts which are subject to rust should be lightly oiled.

WARNING

Particles blown by compressed air are hazardous. Do not exceed 30 psi (207 kPa) air pressure. Make certain the airstream is directed away from user and other personnel in the area. To prevent injury, user must wear protective goggles or face shield when using compressed air.

- c. Blow out tapped (threaded) holes with compressed air to remove dirt and cleaning fluids.

INSPECTION INSTRUCTIONS

All components and parts must be carefully checked to determine:

- a. If they are serviceable for reuse.
- b. If they can be repaired.
- c. If they must be scrapped.

DRILLED AND TAPPED (THREADED) HOLES

- a. Inspect for wear, distortion, cracks, or any other damage in or around holes.
- b. Inspect threaded areas for wear, distortion (stretching), or evidence of crossthreading.
- c. Mark all damaged areas for repair or replacement.

METAL LINES, FLEXIBLE LINES (HOSES), AND METAL FITTINGS

- a. Inspect metal lines for sharp kinks, cracks, bad bends, or dents.
- b. Inspect flexible lines for fraying, evidence of leakage, or loose metal fittings or connectors.
- c. Check all metal fittings and connectors for thread damage, and check hex heads that are worn or rounded by poorly fitting wrenches.
- d. Mark all damaged material for repair or replacement,

MACHINED METAL PARTS

- a. Inspect machined surfaces for nicks, burrs, raised metal, wear, or any other damage.
- b. Check all inner and outer surfaces for breaks or cracks.
- c. Allow no more than two 1/4-inch deep dents in the blower housing assembly or the heater housing assembly. No dent of any size should affect the function or installation of the heater.
- d. Mark all damaged material for repair or replacement.

TAGGING WIRES AND HOSES

Whenever disconnecting a number of wires or hoses:

1. As soon as the first wire (1) or hose is disconnected, write number 1 on two tags (2) and (3). Secure one tag (2) to the wire (1) or hose and the other tag (3) to the terminal (4), nipple, or fitting.
2. After disconnecting the second wire (5) or hose, write number 2 on two tags (6) and (7). Secure one tag (6) to wire (5) or hose, and second tag (7) to terminal (8), nipple, or fitting.
3. Do the same for all the rest of the wires and hoses.

4. Note what numbers you used on a simple sketch of your own. This will help you to retag in the proper order when you remove the tags from some parts to perform cleaning and maintenance work.
5. Remove tags when finished.

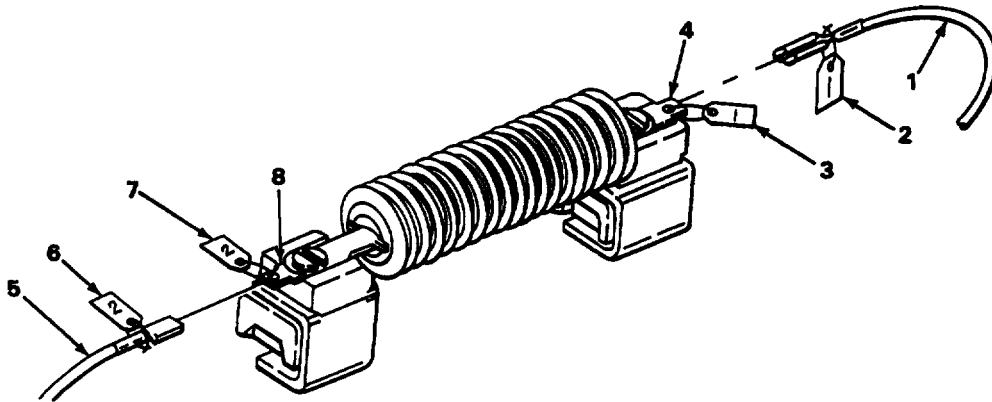

REPAIR INSTRUCTIONS

NOTE

For accuracy, refer to the Source, Maintenance, and Recoverability codes (SMR) assigned to support items listed in the maintenance Repair Parts and Special Tools Lists (RPSTL), Appendix D, contained in this manual.

Any repair procedure peculiar to a specific part or component is covered in the section or paragraph relating to that item. After repair, clean all parts thoroughly to prevent dirt, metal chips, or other foreign material from entering any working parts.

MACHINED METAL PARTS

- a. Repair minor damage to machined surfaces with a fine mill file or crocus cloth dipped in dry cleaning solvent.
- b. Deeply nicked machined surfaces which could affect the assembly operation should be replaced. Notify Direct Support Maintenance.
- c. Minor damage to threaded capscrew holes should be repaired with thread tap of same size to prevent cutting oversize. Notify Direct Support Maintenance.

Section II. REPAIR PARTS, SPECIAL TOOLS; TEST, MEASUREMENT AND DIAGNOSTIC EQUIPMENT (TMDE); AND SUPPORT EQUIPMENT

	Page		Page
Common Tools and Equipment	2-5	Special Tools, TMDE, and	
Repair Parts	2-5	Support Equipment	2-5

COMMON TOOLS AND EQUIPMENT

For authorized common tools and equipment, refer to the Modified Table of Organization and Equipment (MTOE) applicable to your unit.

SPECIAL TOOLS, TMDE, AND SUPPORT EQUIPMENT

No special tools, TMDE, or support equipment are required to maintain the heaters.

REPAIR PARTS

Repair parts are listed and illustrated in Appendix D of this manual.

Section III. SERVICE UPON RECEIPT

No service upon receipt is to be performed on the heaters, other than bleeding the vehicle fuel system after installation. Once installed, service is to be performed only as required.

Section IV. ORGANIZATIONAL PREVENTIVE MAINTENANCE CHECKS AND SERVICES (PMCS)

	Page		Page
General	2-6	PMCS Column Description	2-7
Leakage Definitions.	2-7	Special instructions	2-6
Organizational Preventive Maintenance Checks and Services (PMCS).	2-8		

GENERAL

Preventive maintenance means checking the heater on a regular basis to make sure it works. It also means finding things that are going bad before they fail completely, as well as damage that might have occurred during transport. This helps avoid repair jobs that may take more time.

All items to be checked by Organizational Maintenance appear in the Preventive Maintenance Checks and Services (PMCS) chart in this section. All items are to be checked weekly (every 7 days) or quarterly (every 3 months).

No Organizational PMCS is authorized for the ESPAR V7S.

Record all problems noted on DA Form 2404. Also, record the corrective actions taken to fix the heater. Use the numbers in the Item Number column of the PMCS for the TM Number column on DA Form 2404.

SPECIAL INSTRUCTIONS

If the heater does not work after doing everything listed in the PMCS chart, go to Section V, Organizational Troubleshooting Procedures (page 2-11).

If you find something wrong with the heater that you can't fix, write it down on the DA Form 2404 and notify Direct Support Maintenance.

Always do your preventive maintenance in the same order so it gets to be a habit. Once you've had some practice, you'll spot anything wrong in a hurry. Observe all WARNINGS, CAUTIONS, and NOTES.

WARNING

Dry cleaning solvent PD-680 is both toxic and flammable. Wear protective goggles and gloves, and use only in well-ventilated area. Avoid contact with skin, eyes and clothes, and don't breath vapors. Do not use near open flame or excessive heat. The flashpoint is 100° F to 138° F (38°C to 59°C). If you become dizzy while using dry cleaning solvent, get fresh air immediately and get medical aid. If contact with eyes is made, wash your eyes with water, and get medical aid immediately.

Particles blown by compressed air are hazardous. Do not exceed 30 psi (207 kPa) air pressure. Make sure airstream is directed away from user and other personnel in the area. To prevent injury, user must wear protective goggles or face shield when using compressed air.

SPECIAL INSTRUCTIONS - Continued

Keep It Clean. Dirt, grease, oil and debris only get in the way and may cover up a serious problem. Clean as you work and as needed. Use dry cleaning solvent PD-680 on all metal surfaces. Use soap and water when you clean rubber or plastic material.

Bolts, Nuts, and Screws. Check that they are not loose, missing, bent, or broken. You can't try them all with a tool, of course, but look for chipped paint, bare metal, or rust around boltheads. Tighten any that you find loose.

Welds. Look for loose or chipped paint, rust, or gaps where parts are welded together. If you find a bad weld, report it to Direct Support Maintenance.

Electrical Wires and Connectors. Look for cracked or broken insulation, bare wires, and loose or broken connectors. Tighten loose connectors and make sure the wires are in good condition.

Hoses and Fluid Lines. Look for wear, damage, and leaks. Make sure clamps and fittings are tight. Wet spots show leaks, of course, but a stain around a fitting or connector can also mean a leak. If a leak comes from a loose fitting or connector, tighten it. If something is broken or worn out, either correct it or report it to Direct Support Maintenance (see MAC, Appendix B).

LEAKAGE DEFINITIONS

It is necessary for you to know how fluid leaks affect the status of your equipment. The following are definitions of the types/classes of leakage you need to know to be able to determine the status of your equipment. Learn, and be familiar with them.

Class I	Seepage of fluid (as indicated by wetness or discoloration) not great enough to form drops.
Class II	Leakage of fluid great enough to form drops but not enough to cause drops to drip from the item being checked/inspected.
Class III	Leakage of fluid great enough to form drops that fall from the item being checked/inspected.

PMCS COLUMN DESCRIPTION

The PMCS chart in this section is divided into the following columns:

ITEM - The order that PMCS should be performed, and also used as a source of item numbers for the TM number column on DA Form 2404, Equipment Inspection and Maintenance Worksheet, when recording results of PMCS.

INTERVAL - Tells when each check should be performed. "W" means do the check weekly (every 7 days); "Q" means do the check quarterly (every 3 months).

ITEM TO BE INSPECTED - Lists the checks to be performed.

Table 2-1. Preventive Maintenance Checks and Services for Heaters, Vehicular Compartment

Item No,	Interval	Item To Be Checked Or Serviced	Procedure	Not Fully Mission Capable If:
1	Weekly	Fuel Inspection	<p>NOTE Worn clamps vibrate and work loose easily.</p> <p>a. Check all hoses, clamps and fuel tube connectors (2) for leaks.</p> <p>b. Tighten any loose clamps or connectors (2).</p> <p>c. Replace any leaking hoses or fuel tubes (3).</p>	
2	Quarterly	Mechanical Inspection	<p>a. Remove guard (page 2-31).</p> <p>b. Check all external parts of heater (1) for tightness.</p> <p>c. Replace any missing or damaged screws or nuts.</p>	

The diagram shows an exploded view of a heater assembly. Callout 1 points to a cylindrical component, likely the heater housing or guard. Callout 2 points to a hose or fuel tube connector. Callout 3 points to a fuel tube or hose. The main assembly is shown in a perspective view, with the callout items positioned around it to show their relative positions.

Table 2-1. Preventive Maintenance Checks and Services for Heaters, Vehicular Compartment

Item No.	Interval	Item To Be Checked Or Serviced	Procedure	Not Fully Mission Capable If:
3	Quarterly	Electrical Inspection	<p>a. Check for loose electrical connections (4).</p> <p>b. Check all wires (5) for broken or frayed insulation.</p> <p>c. Tape any damaged insulation.</p> <p>d. Check terminal strip(6) for damage (cracks, chipping, loose terminals).</p>	

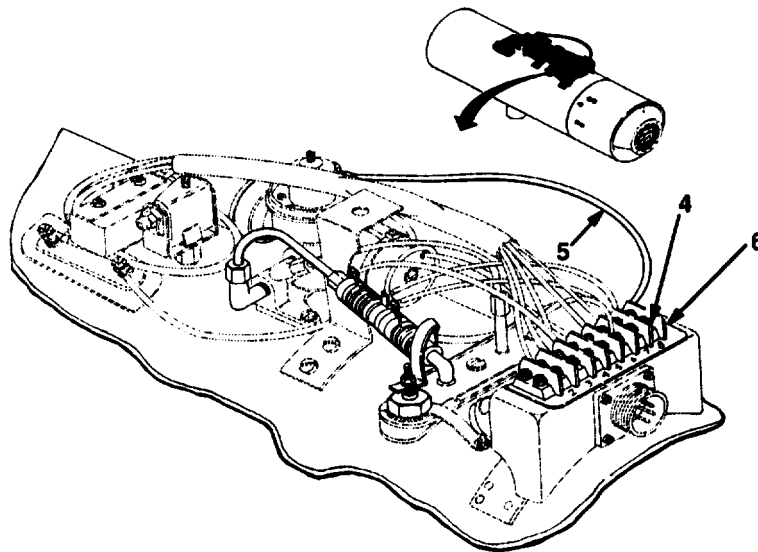

Table 2-1. Preventive Maintenance Checks and Services for Heaters, Vehicular Compartment

Item No.	Interval	Item To Be Checked Or Serviced	Procedure	Not Fully Mission Capable If:
4	Quarterly	Igniter Check	<p>a. Remove igniter (7) from heater (1) (page 2-31).</p> <p>b. inspect ignitor (7) for signs of damage (mashed, burned, or pitted surfaces).</p> <p>c. Replace igniter (7) if damaged (page 2-31).</p> <p>d. Check to make sure igniter (4) to ignition control lead is attached to ignition control end farthest from igniter (Stewart-Warner 10560C24, 10560M, 10560G, and 10560M24B1 only).</p> <p>e. Check igniter gasket seal (Stewart-Warner 10560C24, 10560M, 10560G, and 10560M24B1 only).</p>	

The diagram shows a detailed view of a heater assembly. A cylindrical igniter, labeled '7', is shown in an exploded view above the main heater unit, labeled '1'. The heater unit is a complex assembly with various electrical components, wires, and a mounting bracket. The igniter is connected to the heater via a lead. The drawing is a technical line drawing with dashed lines indicating hidden parts.

Table 2-1. Preventive Maintenance Checks and Services for Heaters, Vehicular Compartment

Item No.	Interval	Item To Be Checked Or Serviced	Procedure	Not Fully Mission Capable If:
5	Quarterly	Fuel Regulator Valves	Service fuel regulator valves for all models except for ESPAR V7S (page 2-31).	
6	Quarterly	Exhaust System Check	<p style="text-align: center;">NOTE</p> <p>Look for signs of water in the exhaust system. If you find any, remove heater from vehicle and dump water out of heater.</p> <p>a. Inspect exhaust system of vehicles.</p> <p>b. Remove any objects that may be blocking the exhaust system.</p>	
7	Quarterly	Operational Check	<p style="text-align: center;"><u>CAUTION</u></p> <p>Heater manufacturers have issued new starting procedures for their heaters. These procedures must be followed for proper heater operation and to prevent ignition system damage. Start-up procedures appear on page 2-59.</p> <p>a. Install guard (page 2-31).</p> <p>b. Start heater (page 2-59).</p> <p>c. Listen for any unusual noises during heater operation.</p>	

Table 2-1. Preventive Maintenance Checks and Services for Heaters, Vehicular Compartment

Item No.	Interval	item To Be Checked Or Serviced	Procedure	Not Fully Mission Capable if:
7	Quarterly	Operational Check Continued	<p style="text-align: center;">CAUTION</p> <p>Do not shut heater off with vehicle master switch. On some vehicles, the vehicle master switch can shut heater off without purging. Always use the heater control box switch.</p> <p>d. Make sure heater purges properly after shut-down (page 2-15).</p>	

WIRING DIAGRAMS

HUPP

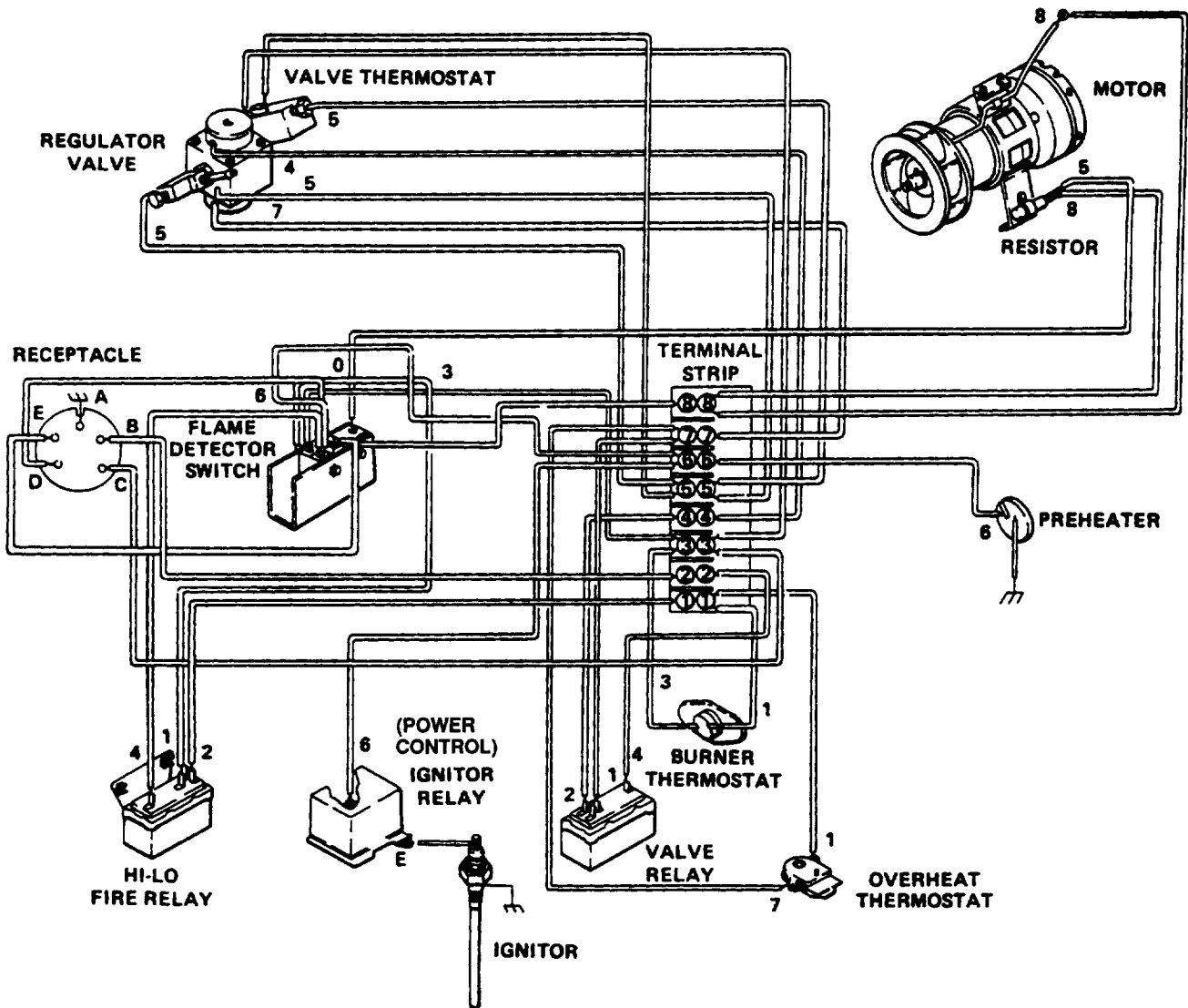

WIRING DIAGRAMS - Continued

STEWART-WARNER

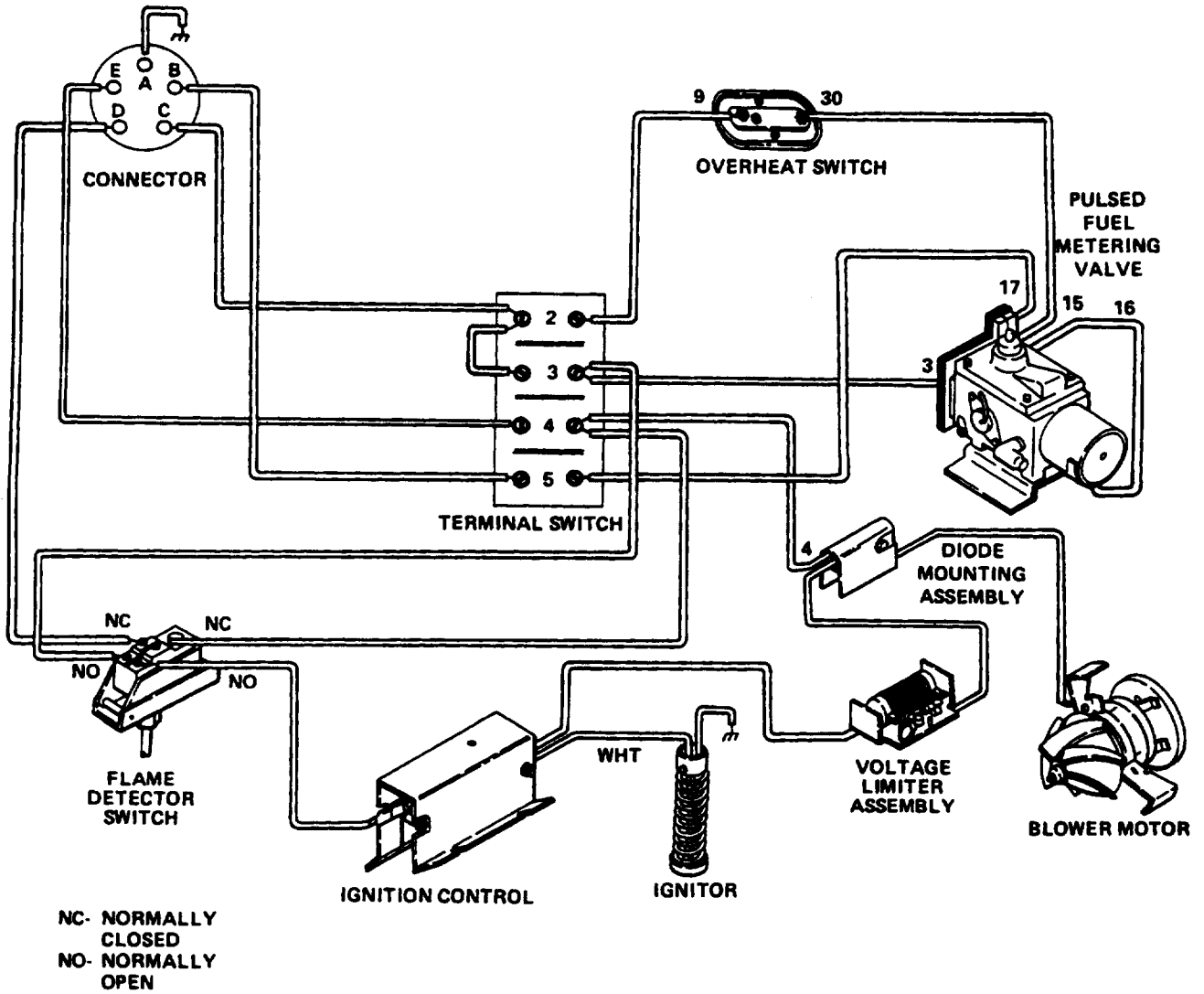

Section V. ORGANIZATIONAL TROUBLESHOOTING

HUPP MF510B, MF510C, MF60A-24V, MF60B-24V

MALFUNCTION

TEST OR INSPECTION

CORRECTIVE ACTION

1. HEATER DOES NOT START

Step 1. Check for blocked air inlet or exhaust pipe.

Clear all passages to and from the heaters (refer to applicable vehicle technical manuals).

Step 2. Check for adequate fuel supply.

Troubleshoot vehicle fuel system (refer to applicable vehicle technical manuals).

Step 3. Check for proper voltage requirements as follows:

- a. Disconnect control box cable to heater.
- b. Using multimeter set to read dc voltage, put red probe on terminals of control box cable and black probe to good ground.

If multimeter reads anything other than 19 volts to 28 volts, troubleshoot vehicle electrical system (refer to applicable vehicle technical manuals).

Step 4. Check for flooded heater (page 2-19).

Step 5. Remove guard (page 2-31).

Step 6. Check heater as follows:

- a. Start heater (page 2-60).

NOTE

On most vehicles, MF510B, MF510C and MF60B-24V heaters get their intake air from outside the vehicle. Choke these heaters by going outside the vehicle and covering the intake elbow.

- b. Hold hand over air intake grill for five seconds and then remove for ten seconds.
- c. Repeat step b for two minutes or until heater starts.

if heater starts, notify Direct Support Maintenance for fuel control valve adjustment.

Step 7. Check for defective igniter as follows:

- a. Remove igniter (page 2-35).

ORGANIZATIONAL TROUBLESHOOTING - Continued

HUPP MF510B, MF510C, MF60A-24V, MF60B-24V - Continued

MALFUNCTION

TEST OR INSPECTION

CORRECTIVE ACTION

1. HEATER DOES NOT START-Continued

- b. Visually inspect igniter for corrosion or pitting.

If igniter has excessive corrosion or pitting, replace (page 2-35).

- c. Set multimeter for resistance measurements.

- d. Place multimeter probes across igniter terminal (1) and case (2).

If multimeter reading is less than 3.4 ohms or more than 4.2 ohms, replace igniter (page 2-35)

Step 8. Adjust flame detector switch (page 2-34).

Step 9. Check for defective flame detector switch (3) as follows:

- a. Disconnect all leads(4) from the NO and the NC terminals on the flame detector switch (3).

- b. Place one multimeter probe on each terminal marked NO.

If multimeter reading is greater than 1.0 ohm, replace flame detector switch (page 2-33).

- c. Place multimeter probe on each terminal marked NC.

If multimeter reading is less than 1.0 ohm, replace flame detector switch (page 2-33).

Step 10. Clean fuel nozzle (page 2-39).

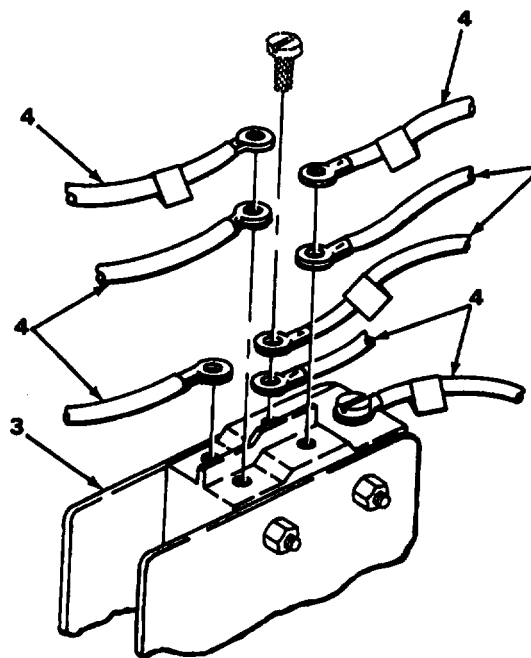
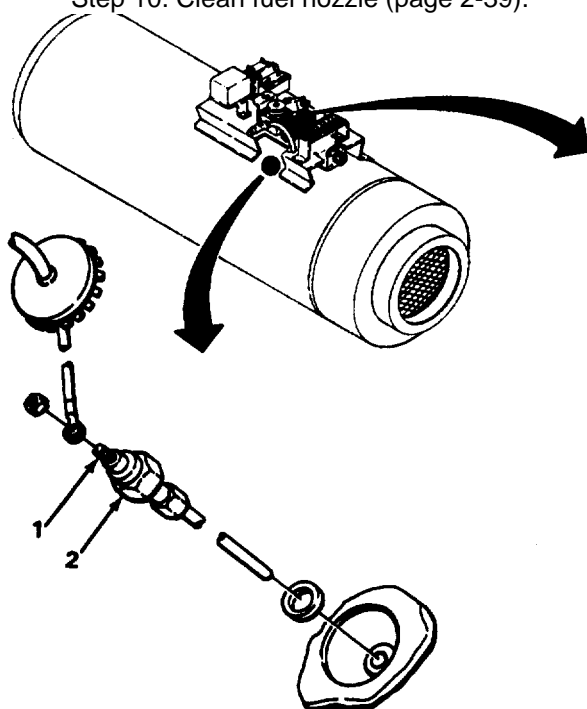

ORGANIZATIONAL TROUBLESHOOTING - Continued

HUPP MF510B, MF510C, MF60A-24V, MF60B-24V - Continued

MALFUNCTION

TEST OR INSPECTION

CORRECTIVE ACTION

1. HEATER DOES NOT START- Continued

Step 11. Try to start heater (page 2-60).

- a. If heater does not start, notify Direct Support Maintenance.
- b. If heater starts, Install guard (page 2-32).

2. HEATER DOES NOT PURGE WHEN TURNED OFF

Step 1. Remove guard (page 2-32).

Step 2. Adjust flame detector switch (page 2-33).

Step 3. Start and stop heater (page 2-60), and wait for it to purge.

- a. If heater still does not purge, notify Direct Support Maintenance.
- b. If heater purges and operates properly, install guard (page 2-32).

3. HEATER DOES NOT START BELOW 40°F (4°C)

Step 1. Check for blocked air inlet or exhaust pipe.

Clear all passages to and from the heater (refer to applicable vehicle technical manuals).

Step 2. Check for adequate fuel supply and fuel waxing or freezing,

Troubleshoot vehicle fuel system (refer to applicable vehicle technical manuals).

Step 3. Check for proper voltage requirements (step 3, malfunction 1).

Step 4. Check for flooded heater (page 2-19),

Step 5. Remove guard (page 2-32).

Step 6. Clean fuel nozzle (page 2-39).

Step 7. Check for defective thermostat assembly (1) as follows:

- a. Connect jumper wire between terminals 3 and 4 of terminal strip (2).
- b. Start heater (page 2-60).

ORGANIZATIONAL TROUBLESHOOTING - Continued

HUPP MF510B, MF510C, MF60A-24V, MF60B-24V - Continued

MALFUNCTION

TEST OR INSPECTION

CORRECTIVE ACTION

3. HEATER DOES NOT START BELOW 40°F (4°C) - Continued

- c. Wait four minutes, then touch fuel regulator valve (3) and fuel reservoir (4).

If fuel regulator valve (3) and fuel reservoir (4) are warm, replace thermostat assembly (page 2-37).

Step 8. Try to start heater below 40°F (4°C) (page 2-60).

- a. If heater does not start, notify Direct Support Maintenance.
- b. If heater starts, install guard (page 2-32).

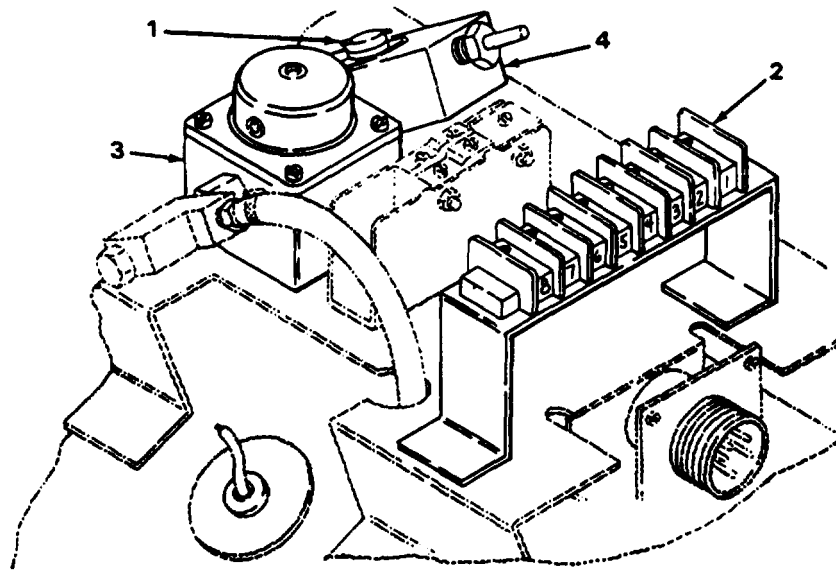

4. FLOODED HEATER

WARNING

Do not try to start a flooded heater with excessive amounts of fuel inside. Explosion may occur, resulting in injury or death to personnel.

Step 1. Demount heater (refer to applicable vehicle technical manuals), and drain excess fuel out of heater through exhaust pipe.

Step 2. install heater (refer to applicable vehicle technical manuals).

ORGANIZATIONAL TROUBLESHOOTING - Continued

HUPP MF510B, MF510C, MF60A-24V, MF60B-24V - Continued

MALFUNCTION

TEST OR INSPECTION

CORRECTIVE ACTION

4. FLOODED HEATER - Continued

Step 3. Remove guard (page 2-32).

Step 4. Disconnect fuel regulator valve (1) lead 7 (4) from terminal 7 of terminal strip (2).

Step 5. Start heater for 4 minutes maximum (page 2-60).

If heater starts, let it run until fuel inside is burned up and heater shuts itself off.

Step 6. Reconnect fuel regulator valve (1) lead 7 (4) to terminal strip (2).

Step 7. Install guard (page 2-32).

if heater did not start, go to malfunction 1, step 5.

5. SHORT IGNITOR LIFE

Step 1. Remove guard (page 2-32).

Step 2. Adjust flame detector switch (page 2-34).

CAUTION

Make sure multimeter is set for dc voltage function before performing step 3 to avoid damage to equipment.

Step 3. Measure voltage across igniter (3) by placing multimeter leads across igniter relay (5)/power control output terminal (6) and ground.

If voltage is more than 25 volts (or more than 18 volts for MF510C, MF60A-24V, and MF60B-24V), remove heater and send to Direct Support Maintenance for igniter relay/power control replacement.

Step 4. Install guard (page 2-32).

6. HEATER SHUTS OFF PREMATURELY

NOTE

This malfunction only applies when air inlet temperature is 60°F(16°C) or above.

ORGANIZATIONAL TROUBLESHOOTING - Continued

HUPP MF510B, MF510C, MF60A-24V, MF60B-24V - Continued

MALFUNCTION

TEST OR INSPECTION

CORRECTIVE ACTION

6. HEATER SHUTS OFF PREMATURELY - Continued

Check to see if heater is or was operating in HI setting.

Operate heater in LO setting only.

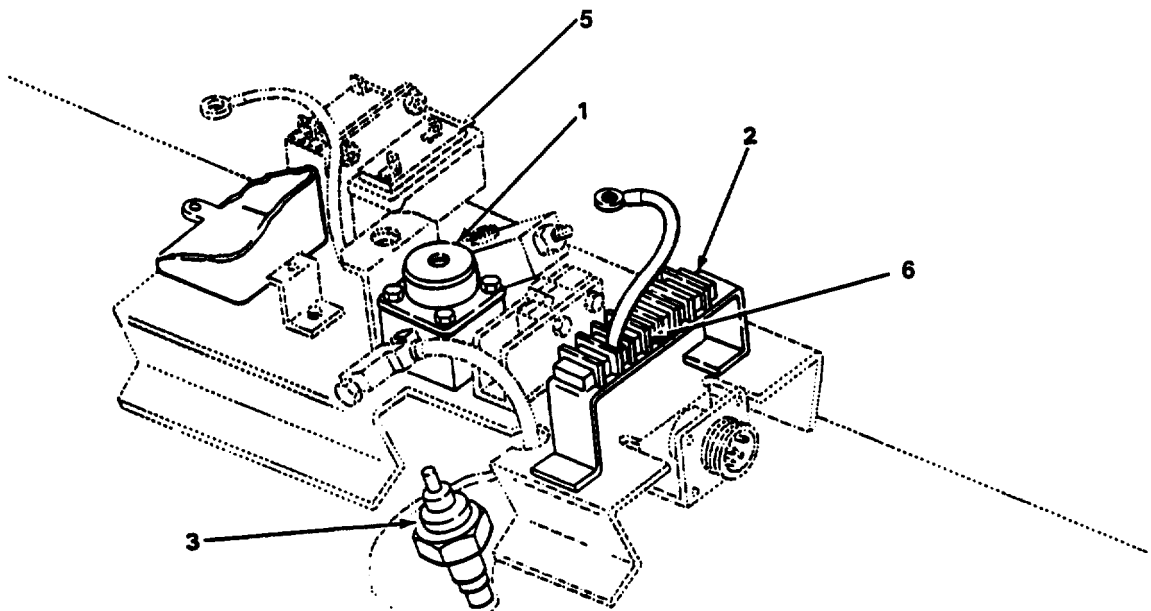

ORGANIZATIONAL TROUBLESHOOTING - Continued

STEWART-WARNER 10560C24, 10560M, 10560M24B1, 10560G

MALFUNCTION

TEST OR INSPECTION

CORRECTIVE ACTION

1. HEATER DOES NOT START

Step 1. Check for blocked air inlet or exhaust pipe.

Clear all passages to and from the heater (refer to applicable vehicle technical manuals).

Step 2. Check for adequate fuel supply.

- a. Bleeding the fuel valve will ensure the heater is receiving fuel (page 2-57).
- b. Troubleshoot vehicle fuel system (refer to applicable vehicle technical manuals).

Step 3. Check for proper voltage requirements as follows:

- a. Check terminal strip (5) for damage (page 2-45).
- b. Disconnect control box cable to heater.
- c. Using multimeter set to read dc voltage, put red probe on terminals of control box cable and black probe to good ground.

If multimeter reads anything other than 19 volts to 28 volts, troubleshoot vehicle electrical system (refer to applicable vehicle technical manuals).

Step 4. Remove guard (page 2-42).

Step 5. Check for flooded heater (page 2-29).

Step 6. Check for wet pulsed fuel metering valve circuit board (1) (10560M24B1 and 10560G).

- a. If wet, dry thoroughly.
- b. Try to start heater (page 2-60).

NOTE

10560M and 10560M24B1 heaters get their intake air from outside the vehicle, Choke these heaters by having someone stand outside the vehicle covering the grill with hand. The 10560C24 and 10560G get air intake from inside the vehicle.

Step 7. Choke heater as follows:

- a. Restrict the air intake by placing hand over intake grill.
- b. Turn heater on for 30 seconds.
- c. Turn heater off, and wait five seconds.
- d. Repeat steps b and c five times or until heater starts.

If heater starts, but needs to be choked often, notify Direct Support Maintenance.

ORGANIZATIONAL TROUBLESHOOTING - Continued

STEWART-WARNER 10560C24, 10560M, 10560M24B1, 10560G - Continued

MALFUNCTION

TEST OR INSPECTION

CORRECTIVE ACTION

1. HEATER DOES NOT START - Continued

Step 8. Remove guard (page 2-42).

Step 9. Check for defective igniter (2) as follows:

- a. Remove igniter (page 2-49).
- b. Place red multimeter probe on ignitor power lead (3) and black probe on ground lead (4).

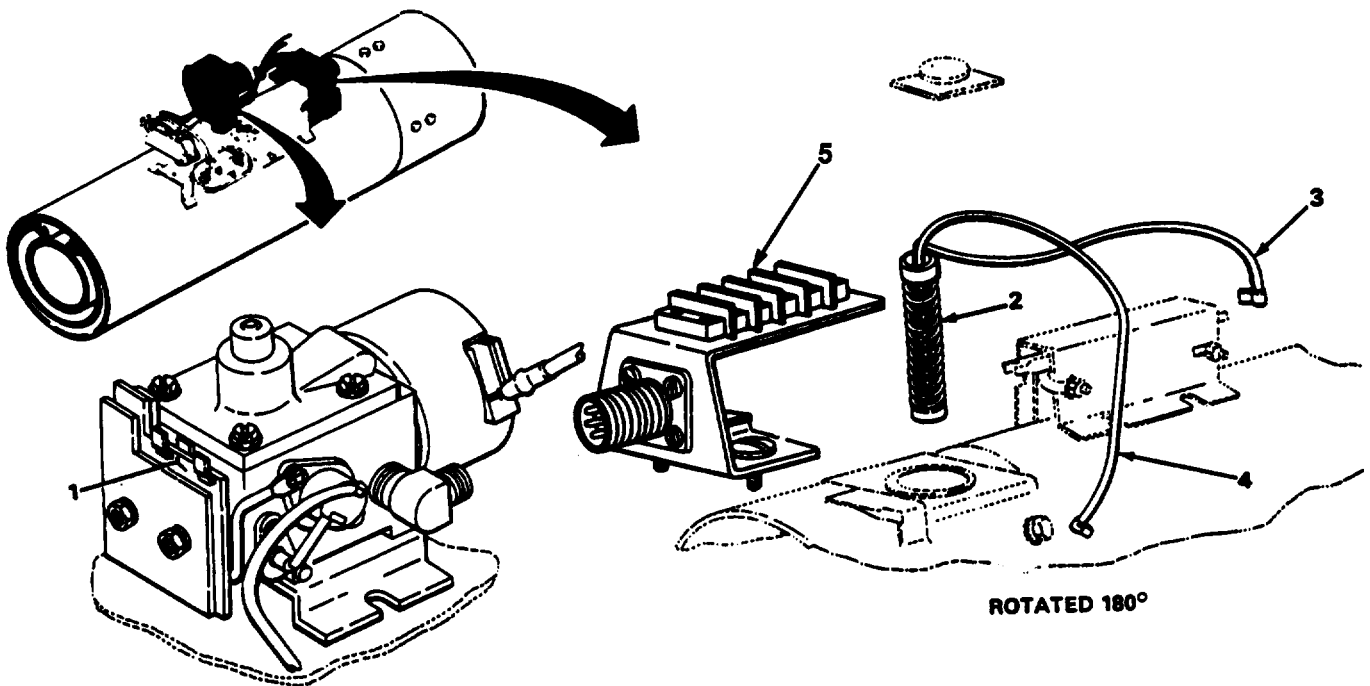

- c. Set multimeter for resistance measurements.

If multimeter reading is less than one ohm or more than two ohms, replace igniter (page 2-49).

- d. Inspect igniter (1) when cold for uneven coil spacing or mashed and burned surfaces.

If igniter (1) shows signs of damage, replace (page 2-49).

ORGANIZATIONAL TROUBLESHOOTING - Continued

STEWART-WARNER 10560C24, 10560M, 10560M24B1, 10560G - Continued

MALFUNCTION

TEST OR INSPECTION

CORRECTIVE ACTION

1. HEATER DOES NOT START- Continued

- e. Connect wires (2) and (3) of igniter (1), turn heater on, and inspect igniter when hot, for hot spots and uneven heating.

Step 10. Check for defective ignition control (4) by placing red multimeter probe on terminal at one end and black probe on terminal at other end.

If multimeter reading is one ohm or more, replace ignition control (page 2-47).

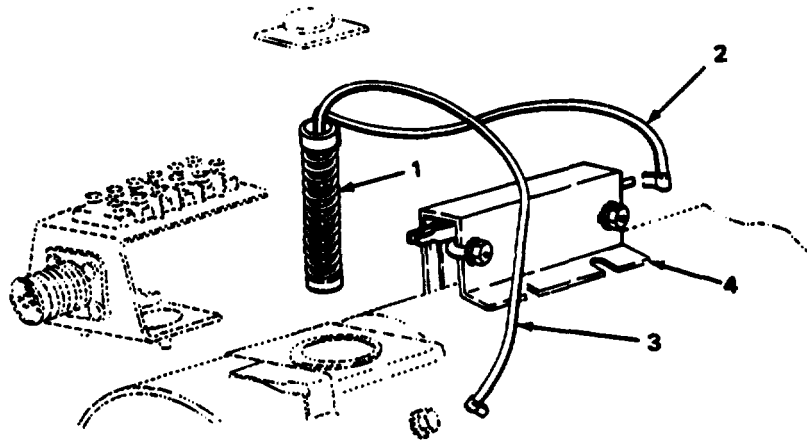

WARNING

The flame detector switch does not control heater temperature. Misadjustments of flame detector switch can cause damage to the heater and may result in injury to personnel. Detector switch must be adjusted when heater is cool.

Step 11. Check for defective flame detector switch (5) as follows:

- a. Disconnect all leads from the flame detector switch (5).
- b. Place one multimeter probe on each NO terminal.

If multimeter reading is greater than one ohm, replace flame detector switch (page 2-43).

Step 12. Adjust flame detector switch (page 2-44).

ORGANIZATIONAL TROUBLESHOOTING - Continued

STEWART-WARNER 10550C24, 10560M, 10550M24B1, 10550G - Continued

MALFUNCTION

TEST OR INSPECTION

CORRECTIVE ACTION

1. HEATER DOES NOT START- Continued

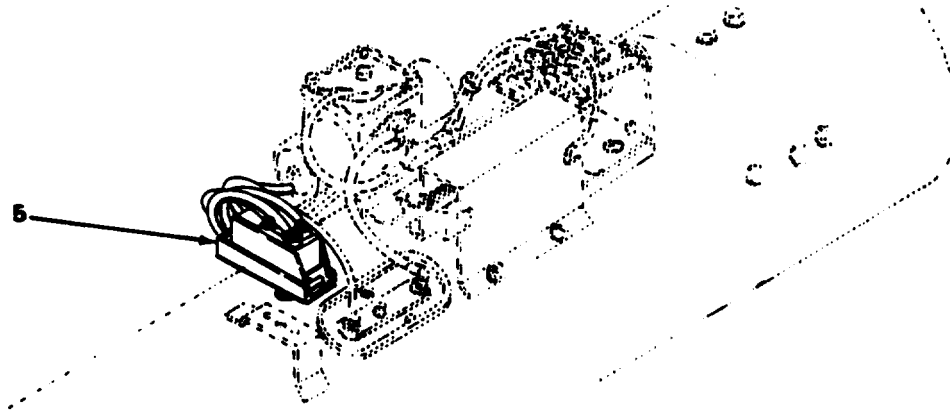

WARNING

The **overheat switch does not control heater temperature. It is a factory-adjusted safety device. Any attempt to adjust this switch may result in injury to personnel.**

Step 13. Check for defective overheat switch (1) by placing multimeter probes across switch terminals 9 and 30.

If multimeter reading is one ohm or more, replace overheat switch (page 2-53).

Step 14. Try to start heater (page 2-59).

- a. if heater does not start, notify Direct Support Maintenance.
- b. if heater starts, install guard (page 2-42).

ORGANIZATIONAL TROUBLESHOOTING - Continued

STEWART-WARNER 10560C24, 10560M, 10560M24B1, 10560G - Continued

MALFUNCTION

TEST OR INSPECTION

CORRECTIVE ACTION

1. HEATER DOES NOT START - Continued

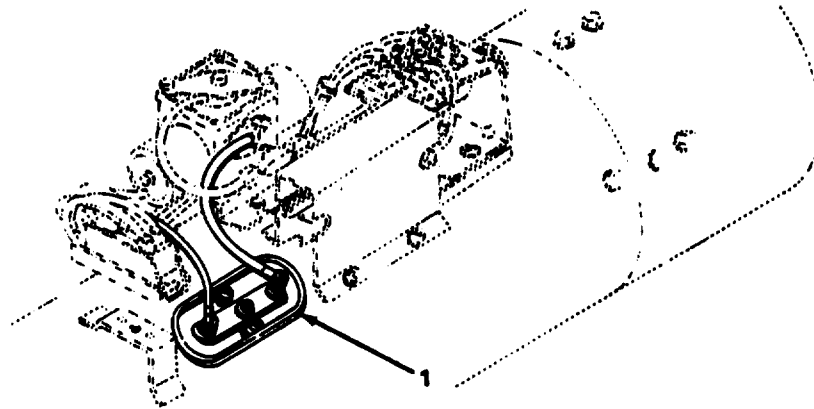

2. HEATER DOES NOT PURGE WHEN TURNED OFF

Step 1. Remove guard (page 2-42).

WARNING

The flame detector switch does not control heater temperature. Misadjustment of flame detector switch can cause damage to the heater and may result in injury to personnel. Detector switch must be adjusted when heater is cool.

Step 2. Adjust flame detector switch (page 2-44).

Step 3. Check for defective flame detector switch (step 10, malfunction 1).

Step 4. Start and stop heater (page 2-59); wait for heater to purge.

- a. if heater still does not purge, notify Direct Support Maintenance.
- b. if heater purges and operates properly, install guard (page 2-42).

ORGANIZATIONAL TROUBLESHOOTING - Continued

STEWART-WARNER 10560C24, 10560M, 10560M24B1, 10560G - Continued

MALFUNCTION

TEST OR INSPECTION

CORRECTIVE ACTION

3. HEATER DOES NOT START BELOW 40°F (4°C)

Step 1. Check for blocked air inlet or exhaust pipe.

Clear all passages to and from the heater (refer to applicable vehicle technical manuals).

Step 2. Check for adequate fuel supply and fuel waxing or freezing.

- a. Bleeding the fuel valve will ensure proper fuel delivery (page 2-57).
- b. Troubleshoot vehicle fuel system (refer to applicable vehicle technical manuals).

Step 3. Check for proper voltage requirements (step 3, malfunction 1).

Step 4. Remove guard (page 2-42).

Step 5. Check for wet pulsed fuel metering valve circuit board (1) (10560M24B1 and 10560G).

- a. If wet, dry thoroughly.
- b. Try to start heater (page 2-59).

Step 6. Choke heater (page 2-22).

Step 7. Check for flooded heater (page 2-29).

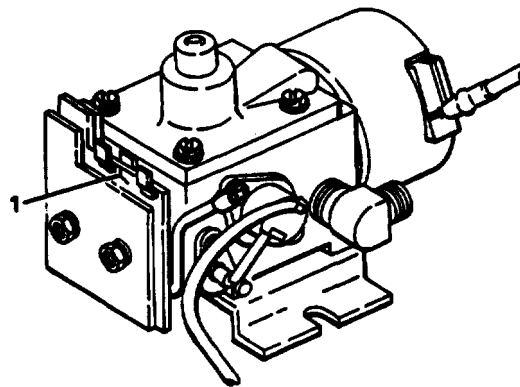

ORGANIZATIONAL TROUBLESHOOTING - Continued

STEWART-WARNER 10560C24, 10560M, 10560M24B1, 10660G - Continued

MALFUNCTION

TEST OR INSPECTION

CORRECTIVE ACTION

3. HEATER DOES NOT START BELOW 40°F (4°C) - Continued

Step 8. Remove thermostat lead (1) from terminal 3 of terminal strip (2).

Step 9. Check heat element inside fuel control valve (3) by placing multimeter leads across heating element terminal (4) and ground.

If multimeter reading is less than 5.5 ohms or more than 6.5 ohms, remove heater from vehicle and send to Direct Support Maintenance for fuel control valve servicing.

Step 10. Connect a jumper wire across terminals of thermostat (5).

Step 11. Reconnect thermostat lead (1) to terminal 3 of terminal strip (2), turn heater on, and wait a few minutes.

If valve does not become warm to the touch, replace valve thermostat (page 2-55).

Step 12. Try to start heater below 40°F (4°C) (page 2-59).

- a. If heater does not start, notify Direct Support Maintenance.
- b. If heater starts, install guard (page 2-42).

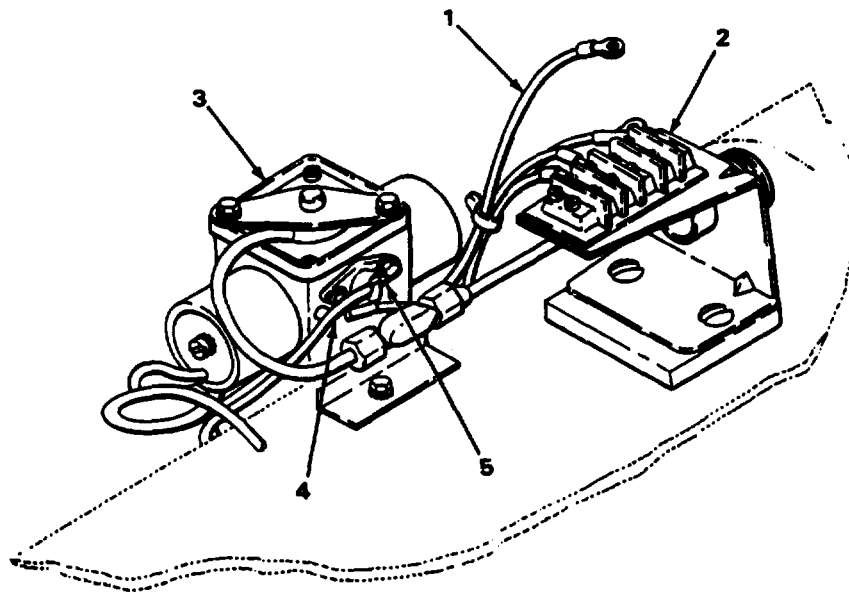

ORGANIZATIONAL TROUBLESHOOTING - Continued

STEWART-WARNER 10560C24, 10560M, 10560M24B1, 10560G - Continued

MALFUNCTION

TEST OR INSPECTION

CORRECTIVE ACTION

4. FLOODED HEATER

WARNING

Do not try to start a flooded heater with excessive amounts of fuel inside. Explosion may occur, resulting in injury or death to personnel.

Step 1. Demount heater (refer to applicable vehicle technical manuals), and drain excess fuel out of heater through exhaust pipe.

Step 2. Install heater (refer to applicable vehicle technical manuals).

Step 3. Remove guard (page 2-42).

Step 4. Disconnect shut-off solenoid lead (6) from terminal 30 of overheat switch (7).

Step 5. Turn heater on for thirty seconds.

Step 6. Turn heater off, and wait for five seconds.

Step 7. Repeat steps 5 and 6 for five to ten minutes or until heater starts.

If heater starts, let it run until fuel inside is burned up and heater shuts itself off.

Step 8. Reconnect lead 30 (6) to overheat switch (7).

Step 9. Install guard (page 2-42).

If heater does not start, go to step 5, malfunction 1.

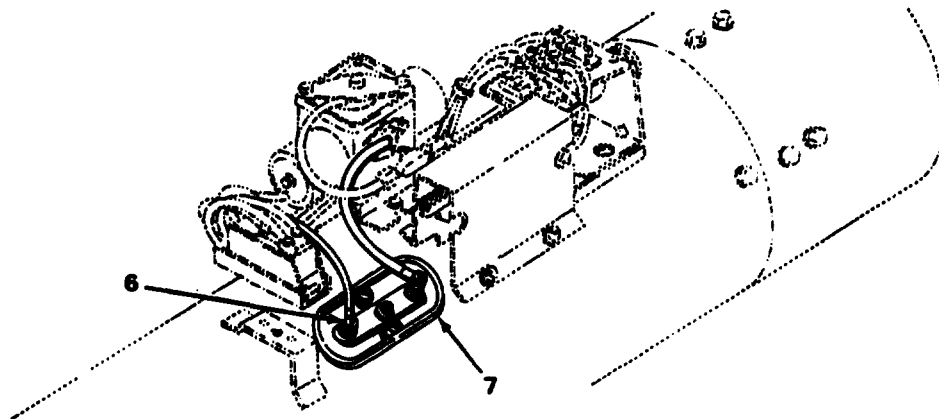

ORGANIZATIONAL TROUBLESHOOTING - Continued

STEWART-WARNER 10560C24, 10560M, 10560M24B1, 10560G - Continued

MALFUNCTION

TEST OR INSPECTION

CORRECTIVE ACTION

5. SHORT IGNITOR LIFE

WARNING

The flame detector switch does not control heater temperature. Misadjustment of flame detector switch can cause damage to the heater and may result in injury to personnel. Detector switch must be adjusted when heater is cool.

Step 2. Adjust flame detector switch (page 2-43).

Step 3. Check to make sure igniter lead (1) is connected to ignition control (2) at terminal nearest the flame detector switch (3).

If ignitor lead is connected to the wrong terminal, move it.

CAUTION

Make sure multimeter is set for dc voltage function before performing step 4 to avoid damage to equipment.

Step 4. Measure ignitor voltage by placing multimeter leads across terminal of ignition control (2) and ground.

If meter reading is more than 12 volts, replace ignition control (page 2-47).

Step 5. Install guard (page 2-42).

6. HEATER SHUTS OFF PREMATURELY

NOTE

This malfunction only applies when air inlet temperature is 60°F (16°C) or above.

Check to see if heater is or was operating in HI setting.

Operate heater in LO setting only.

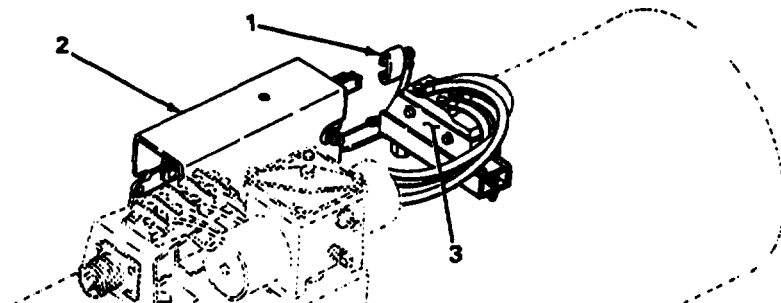

Section VI. ORGANIZATIONAL MAINTENANCE PROCEDURES

	Page		Page
Flame Detector Switch - Hupp MF510B, MF510C, MF60A-24V, MF60B-24V	2-33	Igniter - Stewart-Warner 10560C24, 10560M, 10560G, 10560M24B1 . . .	2-49
Fuel Regulator Valve - Hupp MF510B, MF510C, MF60A-24V, MF60B-24V	2-39	Overheat Switch - Stewart-Warner 10560C24, 10560M, 10560G 10560M24B1	2-53
Fuel Regulator Valve - Stewart- Warner 10560C24m, 10560M; Pulsed Fuel Metering Valve, 10560M24B1,10560G	2-57	Terminal Strip-Stewart-Warner 10560C24, 10560M, 10560G, 10560M24B1	2-45
Guard - Stewart-Warner 10560C24, 10560M, 10560M24B1, 10560G	2-42	Thermostatic Switch (Flame Detector Switch) - Stewart-Warner 10560C24, 10560M, 10560G, 10560M24B1	2-43
Guard - Hupp MF510B, MF510C, MF60A-24V, MF60B-24V	2-32	Valve Thermostat - Hupp MF510B, MF510C, MF60A-24V, MF60B-24V	2-37
Ignition Control - Stewart-Warner 10560C24, 10560M, 10560M24B1 , 10560G	2-47	Valve Thermostat - Stewart-Warner 10560C24, 10560M, 10560G, 10560M24B1	2-55
Igniter - Hupp MF510B, MF510C, MF60A-24V, MF60B-24V	2-35		

GUARD - HUPP MF510B, MF510C, MF60A-24V, MF60B-24V

This task covers:

- a. Removal
- b. Installation

INITIAL SETUP

Tools

Tool Kit, Mechanics Gen (Item 1, Appendix B)

LOCATION	ITEM	ACTION REMARKS
REMOVAL		
1. Guard (1)	Fastener (2)	Unscrew as far as necessary.
2. Heater (3)	Guard (1)	Remove.
INSTALLATION		
3. Heater (3)	Guard (1)	Install.
4. Guard (1)	Fastener (2)	Tighten.

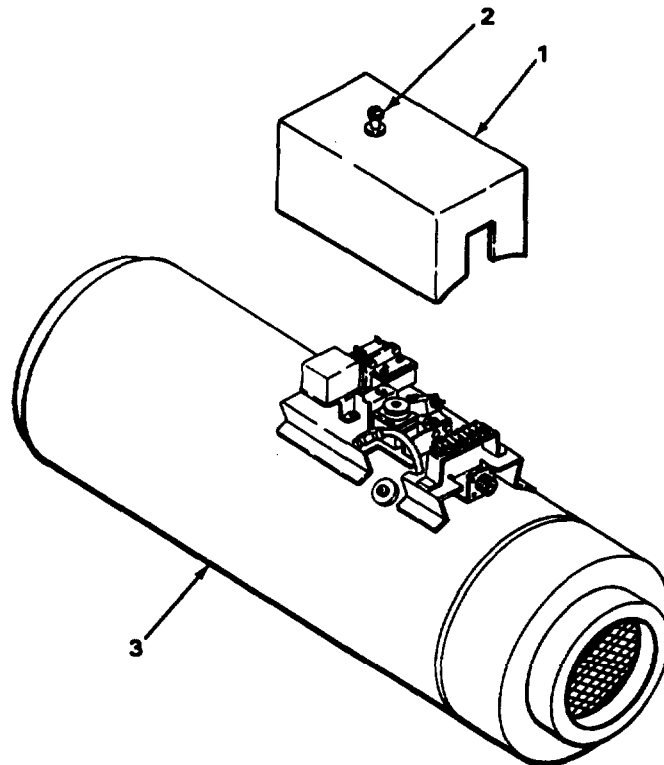

TASK ENDS HERE

FLAME DETECTOR SWITCH -HUPP MF510B, MF510C, MF60A-24V, MF60B-24V

This task covers:

- | | |
|---|---|
| <ul style="list-style-type: none"> a. Removal b. Installation | <ul style="list-style-type: none"> c. Adjustment |
|---|---|

INITIAL SETUP

<p>Tools</p> <p>Tool Kit, Mechanics Gen (Item 1, Appendix B)</p>	<p>Equipment Condition</p> <p>Guard removed (page 2-32).</p>
--	--

Materials/Parts

Sealant, silicon (Item 6, Appendix C)

LOCATION	ITEM	ACTION REMARKS
----------	------	-------------------

REMOVAL

NOTE

Tag all wires and terminals to aid during installation (page 2-3)

1. Flame detector switch (1)	Five screw assemblies (2) and eight leads (3)	Unscrew and remove.
2. Flame detector switch (1) and heater (4)	Nut (5)	Unscrew until threads are free.

CAUTION

Do not bend tube while removing or installing switch. The quartz rod inside may break.

3. Heater (4)	Flame detector switch (1)	Remove.
---------------	---------------------------	---------

INSTALLATION

CAUTION

Do not bend tubing while removing or installing switch. The quartz rod inside may break.

4. Heater (4)	Nut (5)	Screw in and tighten.
5. Flame detector switch (1) and heater (4)	Eight leads (3) and five screw assemblies (2)	Screw in and tighten.
6. Flame detector switch (1)	Insert straight into hole.	

FLAME DETECTOR SWITCH - HUPP MF510B, MF510C, MF60A-24V, MF60B-24V - Continued

LOCATION	ITEM	ACTION REMARKS
----------	------	-------------------

ADJUSTMENT

7. Flame detector switch (1)	Adjusting nut (6)	a. Unscrew until switch clicks, b. Screw in until switch clicks again, c. Screw in one more 1/2-turn. d. Apply sealant,
------------------------------	-------------------	--

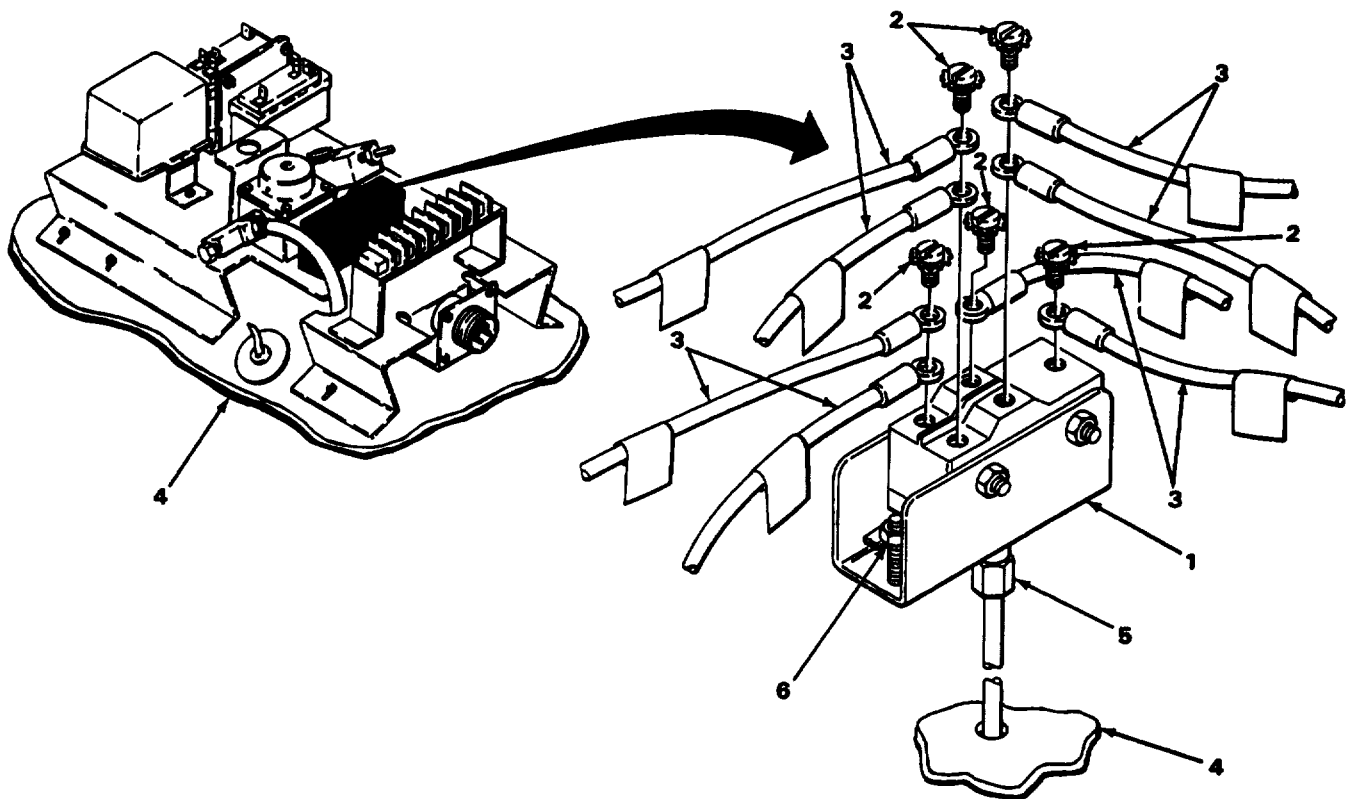

NOTE

FOLLOW-ON MAINTENANCE: Install Guard (page 2-32)

TASK ENDS HERE

IGNITOR - HUPP MF510B, MF510C, MF60A-24V, MF60B-24V

This task covers:

- a. Removal
 - b. Installation
-

INITIAL SETUP

Tools

Tool Kit, Mechanics Gen (Item 1, Appendix B)
 Socket, deep-well, 1/2-inch drive, 13/16-inch
 (item 2, Appendix B)

Equipment Condition

Guard Removed (page 2-32)

Materials/Parts

Gasket

LOCATION	ITEM	ACTION	REMARKS
----------	------	--------	---------

REMOVAL

NOTE

Tag all wires and terminals to aid during Installation (page 2-3)

1. Heater (1)	igniter cover (2)	Remove.	
2. igniter (3)	Nut assembly (4)	Unscrew and remove.	
3.	Lead (5)	Remove.	
4. Heater (1)	igniter (3)	a. Unscrew until threads are free. b. Lift straight out.	Use care not to drop gasket (6) in heater (1).
5. igniter (3)	Gasket (6)	Remove.	

INSTALLATION

6. Igniter (3)	Gasket (6)	Install.	
7. Heater (1)	igniter (3)	a. Slide straight in until it stops. b. Screw in and tighten.	

IGNITOR - HUPP MF510B, MF510C, MF60A-24V, MF60B-24V - Continued

LOCATION	ITEM	ACTION REMARKS
8. Igniter (3)	Lead (5)	Install.
9.	Nut assembly (4)	Screw on and tighten.
10. Heater (1)	Igniter cover (2)	Snap into place.

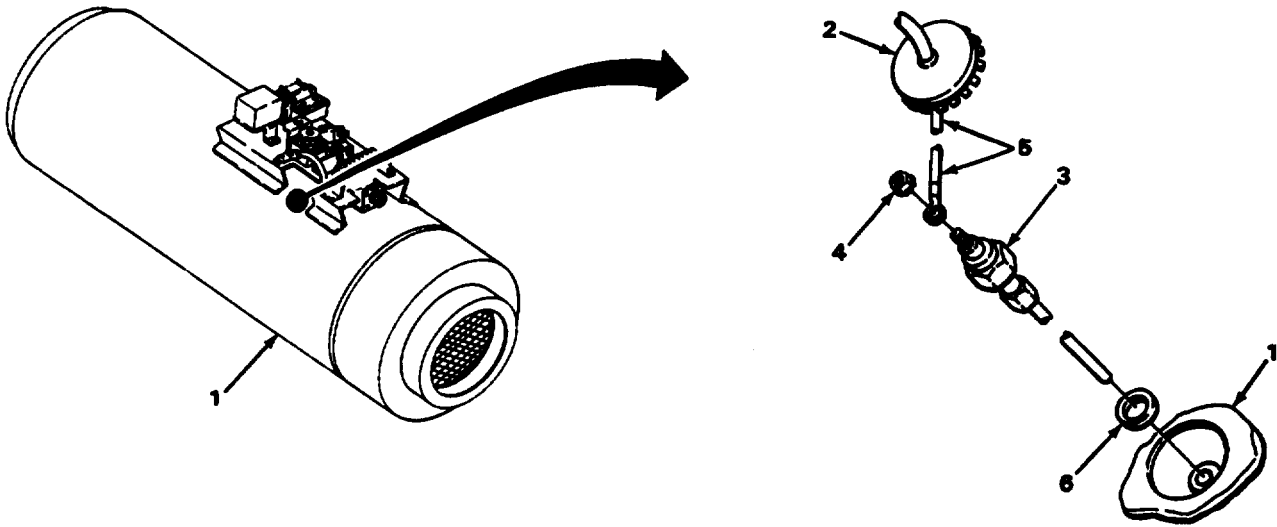

NOTE

FOLLOW-ON MAINTENANCE: Install guard (page 2-32).

TASK ENDS HERE

THERMOSTAT ASSEMBLY - HUPP MF510B, MF510C, MF60A-24V, MF60B-24V

This task covers:

- a. Removal
 - b. Installation
-

INITIAL SETUP

Tools	Equipment Condition
Tool Kit, Mechanics Gen (Item 1, Appendix B)	Guard removed (page 2-32)

LOCATION	ITEM	ACTION	REMARKS
----------	------	--------	---------

REMOVAL

NOTE

Tag all wires and terminals to aid during installation (page 2-3).

- | | | |
|----------------------------|-----------------------------------|-----------------------|
| 1. Terminal strip (1) | Four leads (2) and two screws (3) | Unscrew and remove. |
| 2. Thermostat assembly (4) | Two screws (5) | Unscrew and remove. |
| 3. Reservoir (6) | Thermostat assembly (4) | Lift out of position. |

INSTALLATION

- | | | |
|----------------------------|-----------------------------------|--|
| 4. Reservoir(6) | Thermostat assembly (4) | Place in position with number 3 wire closest to terminal strip (1). |
| 5. Thermostat assembly (4) | Two screws (5) | Screw in and tighten. |
| 6. Terminal strip (1) | Four leads (2) and two screws (3) | a. Place leads in position on terminals 3 and 5.
b. Screw in and tighten. |

THERMOSTAT ASSEMBLY - HUPP MF510B, MF510C, MF60A-24V, MF60B-24V - Continued

LOCATION	ITEM	ACTION REMARKS
----------	------	-------------------

INSTALLATION - Continued

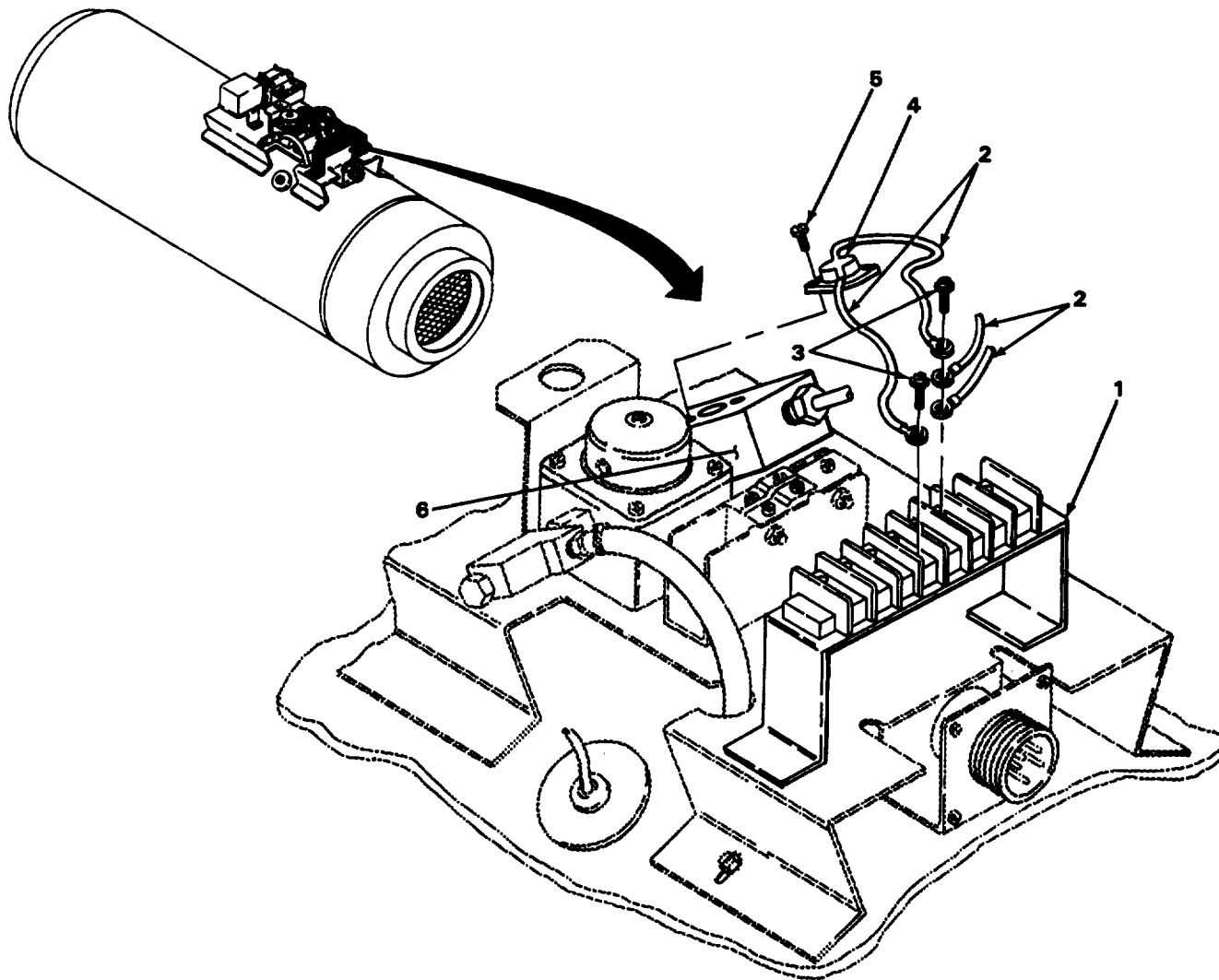

NOTE

FOLLOW-ON MAINTENANCE: Install guard (page 2-32).

TASK ENDS HERE

FUEL REGULATOR VALVE - HUPP MF50B, MF510C, MF60A-24V, MF50B-24V

This task covers:

Service

INITIAL SETUP

Tools

Tool Kit, Mechanics Gen (Item 1, Appendix B)

Equipment Condition

Guard removed (page 2-32)

Materials/Parts

Container, glass, 1/2-gallon capacity
 Goggles, protective
 Hose assembly, non-metallic

LOCATION	ITEM	ACTION REMARKS
SERVICE		
1. Hose clamp (1)	Screw (2)	Unscrew part way.
2. Inlet tube (3)	Hose (4) with hose clamp (1)	a. Remove tube (3). b. Put in glass container. c. Hold RUN/OFF/START switch at RUN. d. Let fuel run steady into glass container until it is clear and bubble free. e. Place RUN/OFF/START switch in Off position.

CAUTION

When removing hose from container, be careful not to let any dirt or particles get into fuel.

		f. Pull hose (4) out of glass container. g. Install on tube (3). h. Discard fuel in container.
3. Hose clamp (1)	Screw (2)	Screw in and tighten.
4. Tee pipe (5)	Plug (6)	Unscrew and remove.

FUEL REGULATOR VALVE - HUPP MF50B, MF510C, MF50A-24V, MF60B-24V - Continued

LOCATION	ITEM	ACTION REMARKS
----------	------	-------------------

SERVICE - Continued

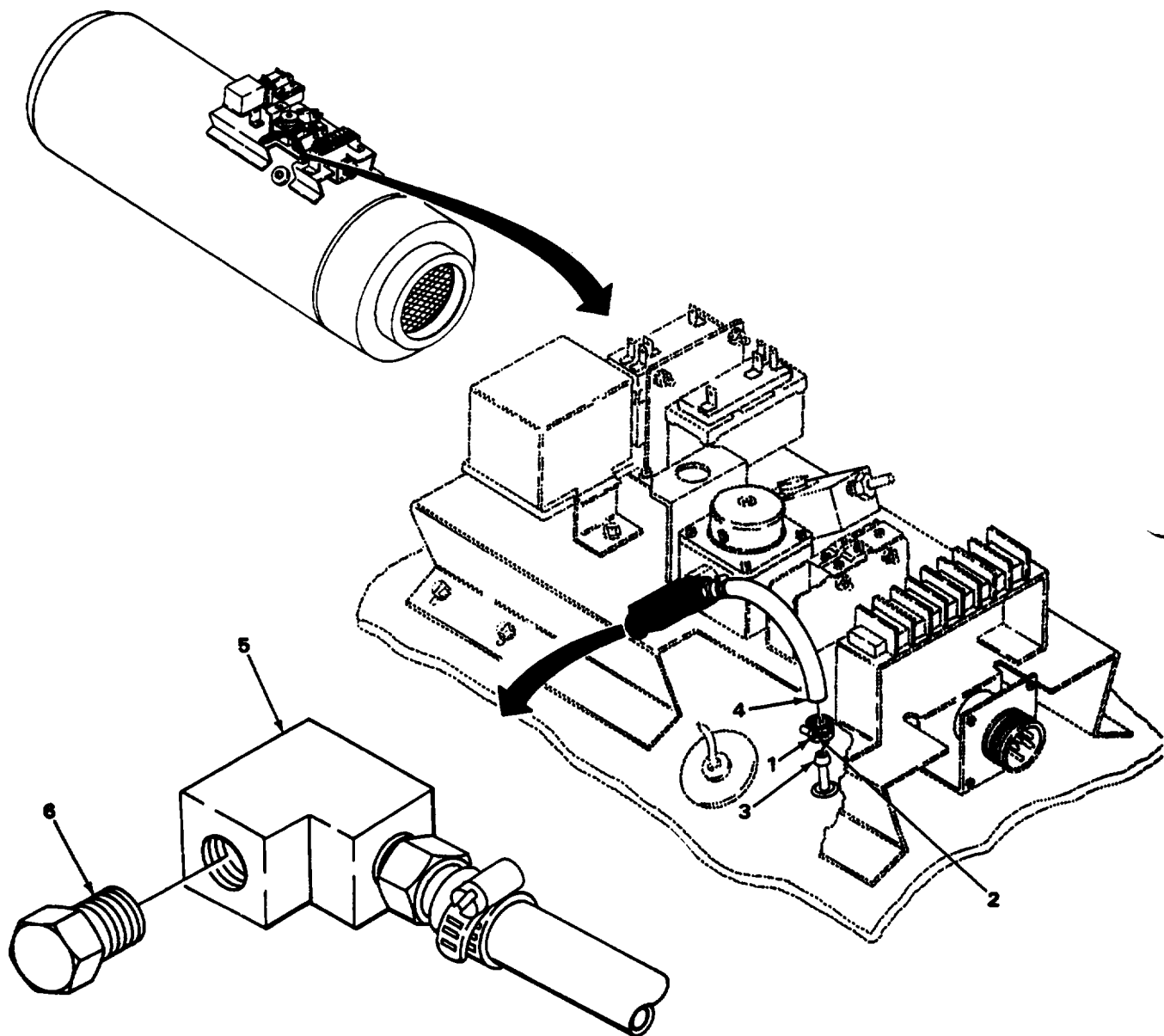

FUEL REGULATOR VALVE - HUPP MF50B, MF510C, MF60A-24V, MF60B-24V - Continued

LOCATION	ITEM	ACTION	REMARKS
----------	------	--------	---------

SERVICE - Continued

- | | | | |
|-----------------|------------|------------------------|--|
| 5. Tee pipe (1) | Nozzle (2) | a. Unscrew and remove. | |
|-----------------|------------|------------------------|--|

WARNING

Particles blown by compressed air are hazardous. Do not exceed 30 psi (207 kPa) air pressure. Make certain airstream is directed away from user and other personnel in the area. To prevent injury, user must wear protective goggles or face shield when using compressed air.

- b. Using compressor, hose, and air gun, blowout until clear.

If nozzle often requires repeated cleaning, notify Direct Support Maintenance.

- c. Screw in and tighten.

- | | | | |
|----|----------|-----------------------|--|
| 6. | Plug (3) | Screw in and tighten. | |
|----|----------|-----------------------|--|

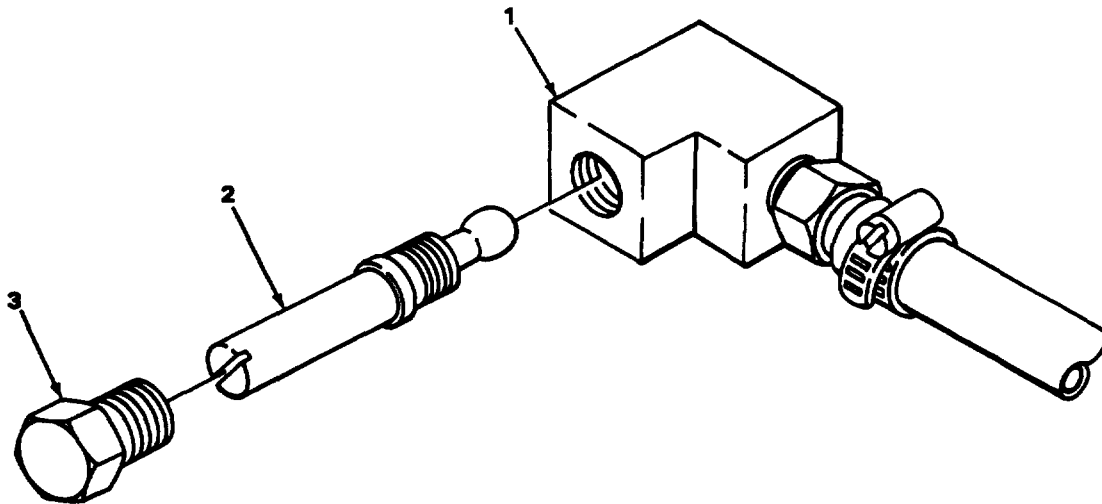

NOTE

FOLLOW-ON MAINTENANCE: Install guard (page 2-32)

TASK ENDS HERE

GUARD - STEWART-WARNER 10560C24, 10560M, 10560M24B1, 10560G

This task covers:

- a. Removal
- b. Installation

INITIAL SETUP

Tools

Tool Kit, Mechanics Gen (Item 1, Appendix B)

LOCATION	ITEM	ACTION	REMARKS
----------	------	--------	---------

REMOVAL

- | | | |
|---------------|-------------------|------------------------|
| 1. Guard (1) | Two fasteners (2) | Unscrew one-half turn. |
| 2. Heater (3) | Guard (1) | Remove. |

INSTALLATION

- | | | |
|---------------|-------------------|-------------------------|
| 3. Heater (3) | Guard (1) | Install. |
| 4. Guard (1) | Two fasteners (2) | Screw in one-half turn. |

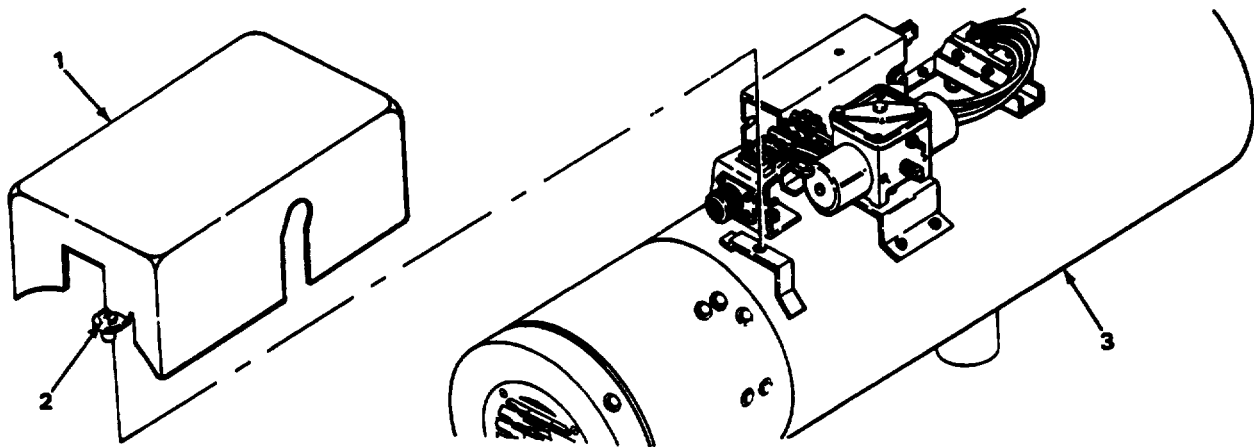

TASK ENDS HERE

THERMOSTATIC SWITCH (FLAME DETECTOR SWITCH) - STEWART-WARNER 10560C24, 10560M, 10560M24B1, 10560G

This task covers:

- a. Removal
- b. Installation
- c. Adjustment

INITIAL SETUP

Tools	Equipment Condition
Tool Kit, Mechanics Gen (Item 1, Appendix B)	Guard removed (page 2-42)
Materials/Parts	
Sealant, silicon (Item 6, Appendix C)	

LOCATION	ITEM	ACTION REMARKS
----------	------	-------------------

REMOVAL

NOTE

Tag all wires and terminals to aid during installation (page 2-3).

- | | | |
|---|---|---------------------------------|
| 1. Flame detector switch (1) | Four screw assemblies (2) and leads (3) | Unscrew and remove. |
| 2. Flame detector switch (1) and heater (4) | Nut (5) | Unscrew until threads are free. |
| 3. Heater (4) | Flame detector switch (1) | Lift straight out. |

INSTALLATION

- | | | |
|---|---|--|
| 4. Heater (4) | Flame detector switch (1) | a. Insert straight into hole.
b. Turn so adjustment screw (6) is away from overheat switch (7). |
| 5. Flame detector switch (1) and heater (4) | Nut (5) | Screw on and tighten. |
| 6. Flame detector switch (1) | Four screw assemblies (2) and leads (3) | Screw in and tighten. |

THERMOSTATIC SWITCH (FLAME DETECTOR SWITCH) - STEWART-WARNER 10560C24, 10560M, 10560M24B1, 10560G - Continued

LOCATION	ITEM	ACTION	REMARKS
----------	------	--------	---------

ADJUSTMENT

WARNING

Only adjust flame detector switch when heater is off and cool. Hot or operating heater can cause serious injury to personnel.

WARNING

The flame detector switch dose not control heater temperature. Misadjustment of flame detector switch can cause damage to the heater and may result in injury to personnel.

CAUTION

Failure to apply sealant to screw will cause switch to go out of adjustment because of vibration. Tell operator to leave adjusting screw alone.

- | | | |
|------------------------------|----------------------|--|
| 7. Flame detector switch (1) | Adjustment screw (6) | <ul style="list-style-type: none"> a. Unscrew partway. b. Screw in until switch (1) clicks. c. After switch (1) clicks, turn 1/2-turn clockwise. d. Apply sealant. |
|------------------------------|----------------------|--|

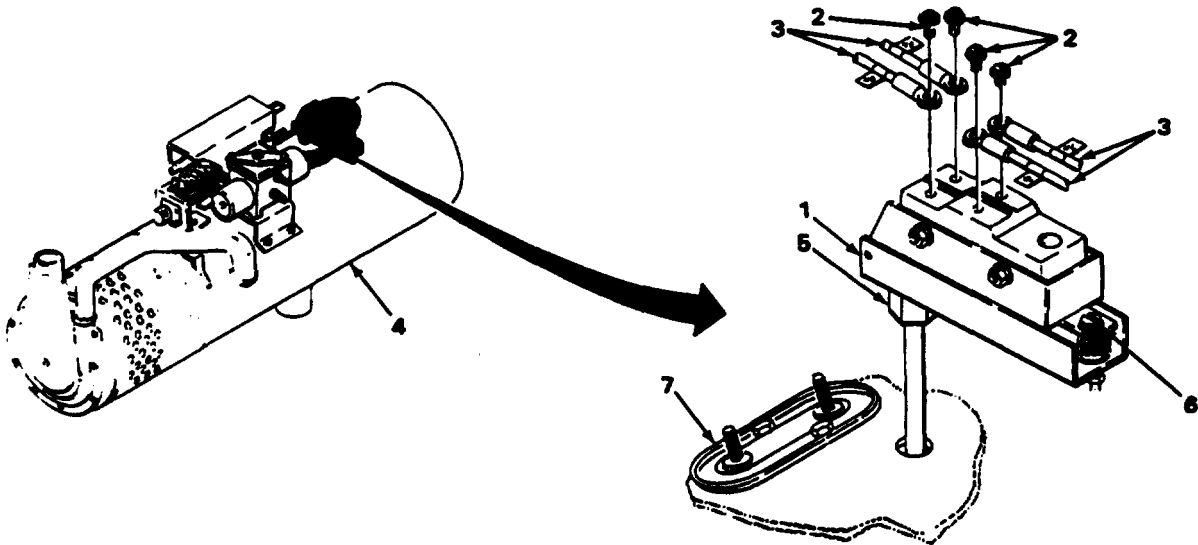

NOTE

FOLLOW-ON MAINTENANCE: Install guard (page 2-42).

TASK ENDS HERE

TERMINAL STRIP - STEWART-WARNER 10560C24, 10560M, 10560M24B1, 10560G

This task covers:

- a. Removal
- b. Installation

INITIAL SETUP

Tools

Equipment Condition

Tool Kit, Mechanics Gen (Item 1, Appendix B)

Guard removed (page 2-42)

LOCATION

ITEM

ACTION

REMARKS

REMOVAL

NOTE

Tag all wires and terminals to aid during installation (page 2-3).

- | | | |
|-----------------------|-------------------------------------|---------------------|
| 1. Terminal strip (1) | Seven screws (2) and nine leads (3) | Unscrew and remove. |
| 2. Terminal strip (1) | Four screws (4) | Unscrew and remove. |

INSTALLATION

- | | | |
|-----------------------|-------------------------------------|----------------------|
| 3. Terminal strip (1) | Four screws (4) | Install. |
| 4. Terminal strip (1) | Seven screws (2) and nine leads (3) | Install and tighten. |

TERMINAL STRIP - STEWART-WARNER 10560C24, 10560M, 10560M24B1, 10560G - CONTINUED

LOCATION	ITEM	ACTION	REMARKS
----------	------	--------	---------

INSTALLATION - Continued

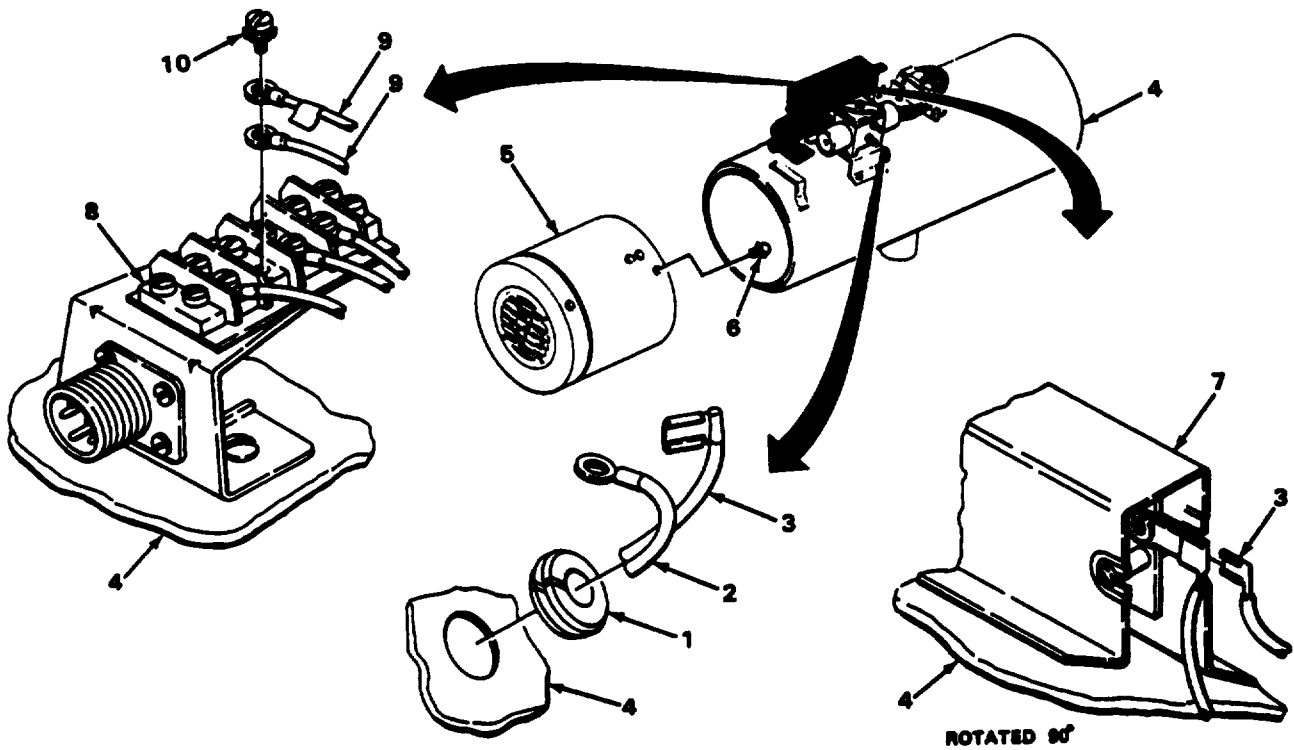

NOTE

FOLLOW-ON MAINTENANCE: Install guard (page 2-42)

TASK ENDS HERE

IGNITION CONTROL - STEWART-WARNER 10550C24, 10560M, 10560M24B1, 10560G

This task covers:

- a. Removal
 - b. Installation
-

INITIAL SETUP

Tools

Equipment Condition

Tool Kit, Mechanics Gen (Item 1, Appendix B)

Guard removed (page 2-42)

LOCATION

ITEM

ACTION

REMARKS

REMOVAL

NOTE

Tag all wires and terminals to aid during installation (page 2-3).

- | | | |
|-------------------------|----------------------------------|--|
| 1. Ignition control (1) | Lead (2), lead (3), and lead (4) | Remove. |
| 2. | Four screw assemblies (5) | <ul style="list-style-type: none"> a. Loosen two assemblies (5) on mounting bracket nearest fuel control valve (6). b. Unscrew and remove other two mounting bracket screw assemblies (5). |
| 3. Heater (7) | Ignition control (1) | Slide out from under screw assemblies (5), and remove. |

INSTALLATION

- | | | |
|-------------------------|----------------------------------|---|
| 4. Heater (7) | Ignition control (1) | Slide slotted mounting bracket under two screw assemblies (5) nearest fuel control valve (6). |
| 5. Ignition control (1) | Two screw assemblies (5) | <ul style="list-style-type: none"> a. Screw in and tighten. b. Tighten two screw assemblies (5) nearest fuel control valve (6). |
| 6. | Lead (4), lead (3), and lead (2) | Install. |

IGNITION CONTROL - STEWART-WARNER 10560C24, 10560M, 10560M24B1, 10560G - Continued

LOCATION	ITEM	ACTION	REMARKS
----------	------	--------	---------

INSTALLATION - Continued

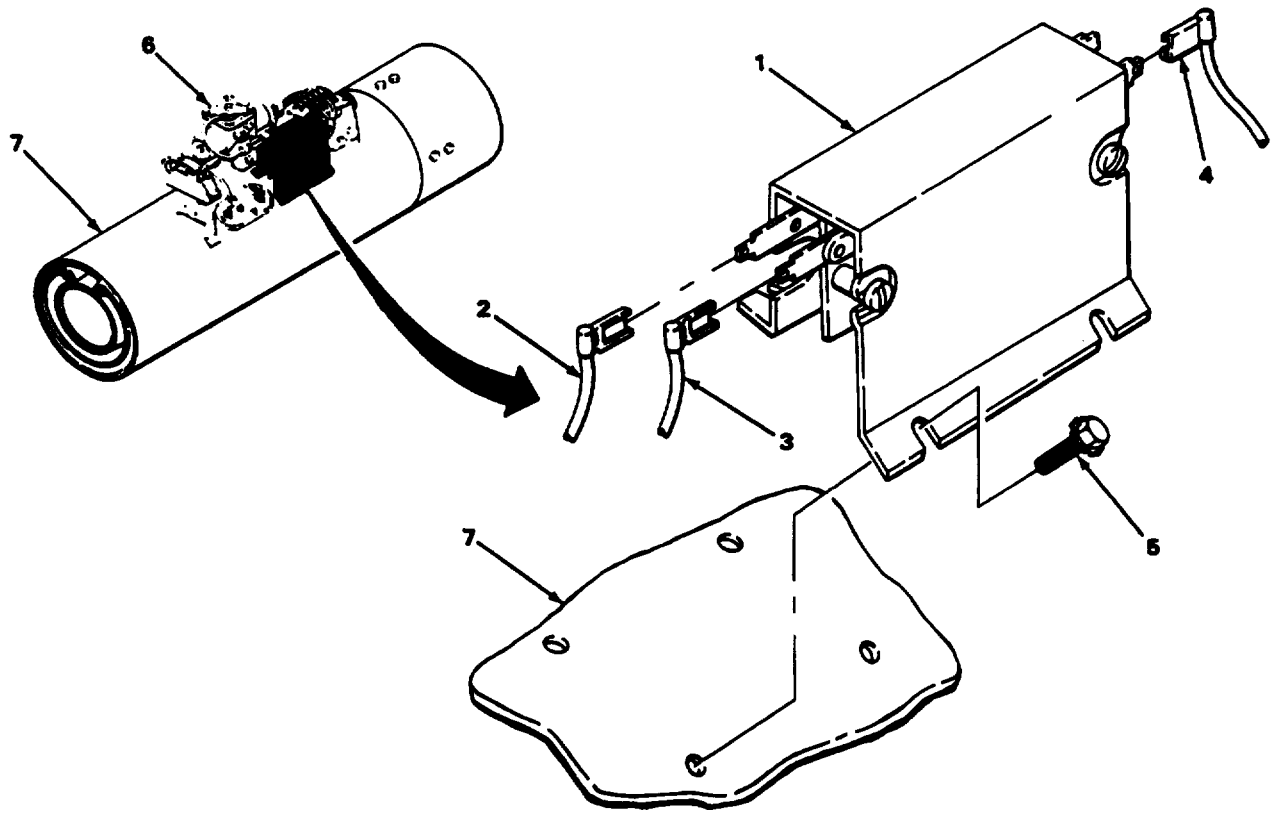

NOTE

FOLLOW-ON MAINTENANCE: Install guard (page 2-42).

TASK ENDS HERE

IGNITOR - STEWART-WARNER 10560C24, 10560M, 10560M24B1, 10560G

This task covers:

- a. Removal
 - b. Installation
-

INITIAL SETUP

Tools

Equipment Condition

Tool Kit, Mechanics Gen (Item 1, Appendix B)

Guard removed (page 2-42)

LOCATION

ITEM

ACTION

REMARKS

REMOVAL

NOTE

Tag all wires and terminals to aid during installation (page 2-3).

1. Electrical inlet assembly (1)	Two fasteners (2)	Loosen by turning one-quarter turn counterclockwise.
2. Heater (3)	Electrical inlet assembly (1)	Lift up and over fuel regulator valve.
3.	Rubber gasket (4)	Remove.
4. Ignition control (5)	Lead (6)	Remove.
5. Ground terminal (7)	Lead (8)	Remove.
6.	Igniter (9)	a. Push in by hand. b. Turn one-eighth turn counterclockwise. c. Remove.

IGNITOR - STEWART-WARNER 10560C24, 10560M, 10560M24B1, 10560G - Continued

LOCATION	ITEM	ACTION	REMARKS
----------	------	--------	---------

REMOVAL - Continued

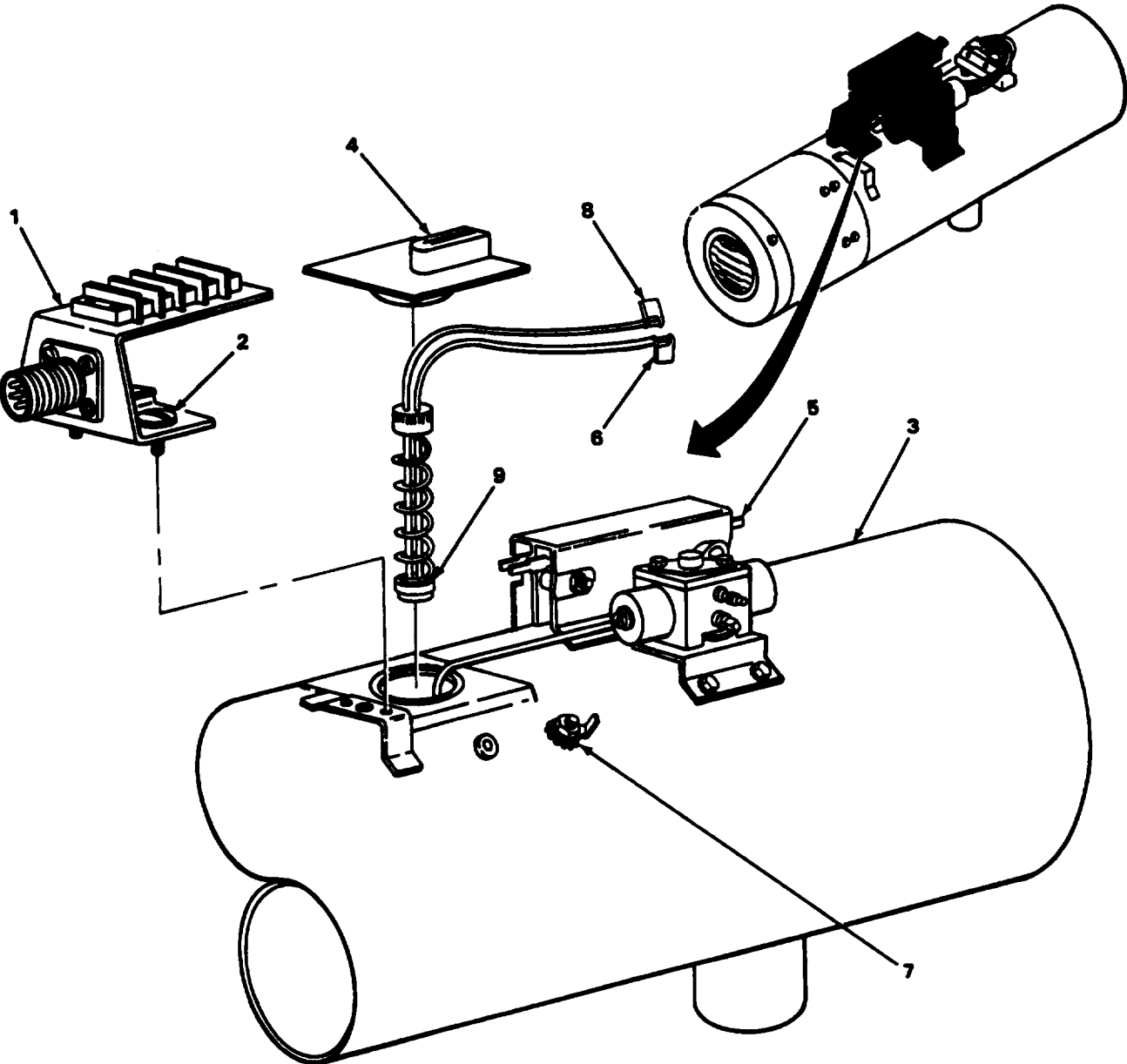

IGNITOR - STEWART-WARNER 10560C24, 10560M, 10560M24B1, 10560G - Continued

LOCATION	ITEM	ACTION REMARKS
INSTALLATION		
7. Heater (1)	Igniter (2)	a. Push in so wires are near fuel tube. b. Turn clockwise until it stops. c. Release. d. Tug slightly on igniter leads and release to seat igniter.
8. Igniton control (3)	Lead (4)	Install.
9. Ground terminal (5)	Lead (6)	Install.

WARNING

Stewart-Warner heaters must not be operated without rubber gaskets covering the igniter. Failure to install this gasket could cause deadly carbon monoxide gas to enter the vehicle and result in personnel injury or death.

10.	Rubber gasket (7)	a. Install around leads (4) and(6) and fuel tube (8). b. Push down.
11. Rubber gasket (7)	Electrical inlet assembly (9)	Install.
12. Electrical inlet assembly (9)	Two fasteners (10)	Turn one-quarter turn clockwise.

IGNITOR - STEWART-WARNER 10560C24, 10560M, 10560M24B1, 10560G - Continued

LOCATION	ITEM	ACTION REMARKS
----------	------	-------------------

INSTALLATION - Continued

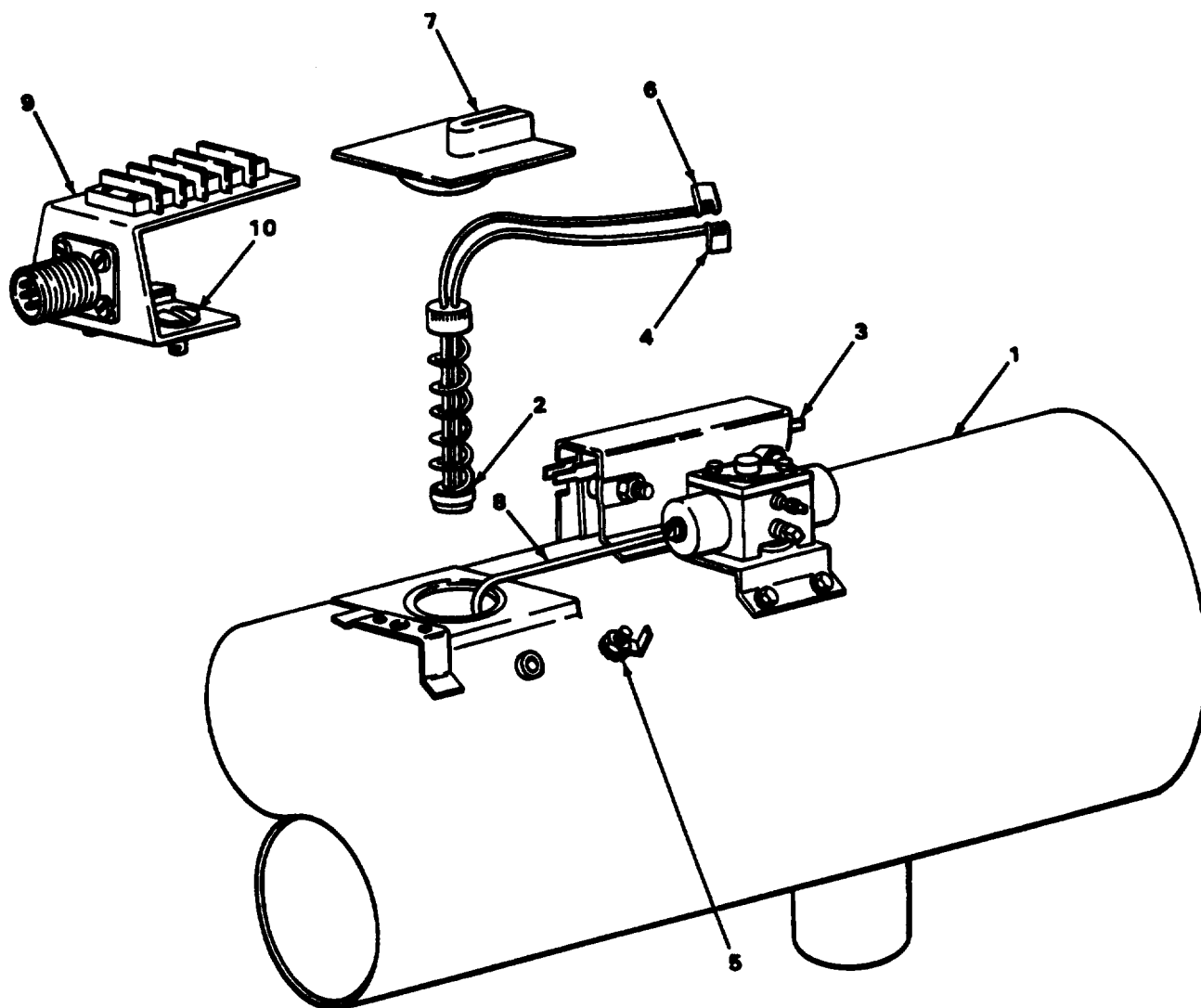

NOTE

FOLLOW-ON MAINTENANCE: Install Guard (page 2-42).

TASK ENDS HERE

OVERHEAT SWITCH - STEWART-WARNER 10560C24, 10560M, 10560M24B1, 10560G

This task covers:

- a. Removal
 - b. Installation
-

INITIAL SETUP

Tools	Equipment Condition
Tool Kit, Mechanics Gen (Item 1, Appendix B)	Guard removed (page 2-42)

LOCATION	ITEM	ACTION	REMARKS
----------	------	--------	---------

REMOVAL

NOTE

Tag all wires and terminals to aid during installation (page 2-3).

1. Overheat switch (1)	Two nut assemblies (2)	Unscrew and remove.
2.	Two leads (3)	Remove.
3.	Two screw assemblies (4)	Unscrew and remove.
4. Heater (5)	Overheat switch (1)	Remove.

INSTALLATION

WARNING

The overheat switch does not control heater temperature. It is a factory-adjusted safety device. Any attempt to adjust this switch may result in injury to personnel.

5. Heater (5)	Overheat switch (1)	Install. Terminal marked "g" goes toward ignition control (6).
6. Overheat switch (1)	Two screw assemblies (4)	Screw in and tighten.
7.	Two leads (3)	Slip onto terminals as marked on leads.
8.	Two nut assemblies (2)	Screw on and tighten.

OVERHEAT SWITCH - STEWART-WARNER 10550C24, 10560M, 10550M24B1, 10560G - Continued

LOCATION	ITEM	ACTION	REMARKS
----------	------	--------	---------

INSTALLATION - Continued

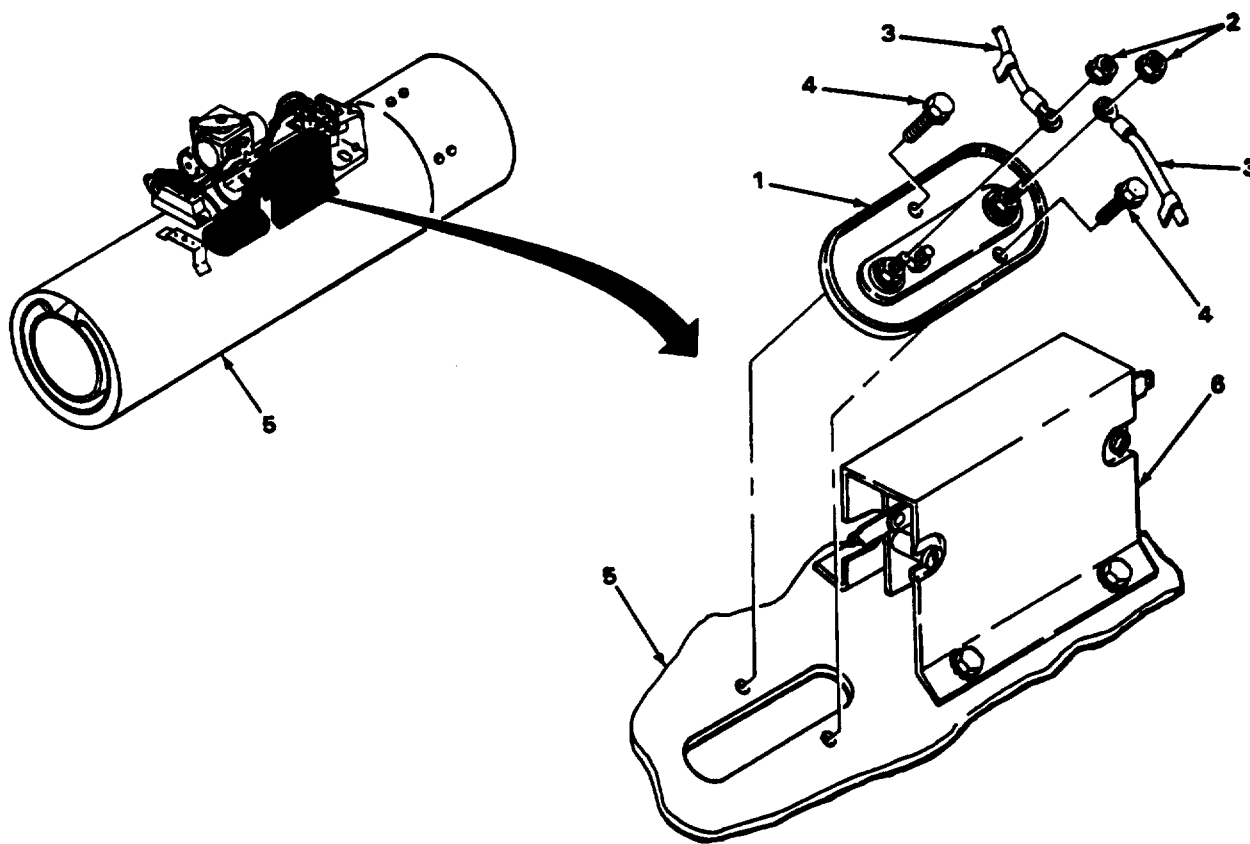

NOTE

FOLLOW-ON MAINTENANCE: Install guard (page 2-42).

TASK ENDS HERE

VALVE THERMOSTAT - STEWART-WARNER 10560C24, 10560M, 10560M24B1, 10560G

This task covers:

- a. Removal
 - b. Installation
-

INITIAL SETUP

Tools	Equipment Condition
Tool Kit, Mechanics Gen (Item 1, Appendix B)	Guard removed (page 2-42)
Soldering tool, gun-type, 115-Vac (Item 4, Appendix B)	

Materials/Parts

- Alcohol, denatured (Item 1, Appendix C)
- Brush, acid swabbing (Item 2, Appendix C)
- Flux, soldering (Item 3, Appendix C)
- Solder (Item 7, Appendix C)

LOCATION	ITEM	ACTION	REMARKS
----------	------	--------	---------

REMOVAL

NOTE

Tag wires and terminals to aid during installation (page 2-3).

1. Valve thermostat (1)	Lead (2)	a. Unsolder. b. Liftoff terminal.
2. Terminal board (3)	Screw assembly (4) and lead (5)	Unscrew and remove.
3. Valve thermostat (1)	Two screws (6)	Unscrew and remove.
4. Fuel regulator valve (7)	Valve thermostat (1)	Remove.

INSTALLATION

5. Fuel regulator valve (7)	Valve thermostat (1)	Install.
6. Valve thermostat (1)	Two screws (6)	Screw in and tighten.

NOTE

Clean all soldered joints with denatured alcohol and acid swabbing brush.

VALVE THERMOSTAT - STEWART-WARNER 10560C24, 10560M, 10560M24B1, 10560G - Continued

LOCATION	ITEM	ACTION	REMARKS
----------	------	--------	---------

INSTALLATION - Continued

- | | | | |
|----|--------------------|---|--|
| 7. | Lead (2) | Solder to bottom terminal. | |
| 8. | Terminal board (3) | Lead (5) and screw assembly (4) Screw in and tighten. | |

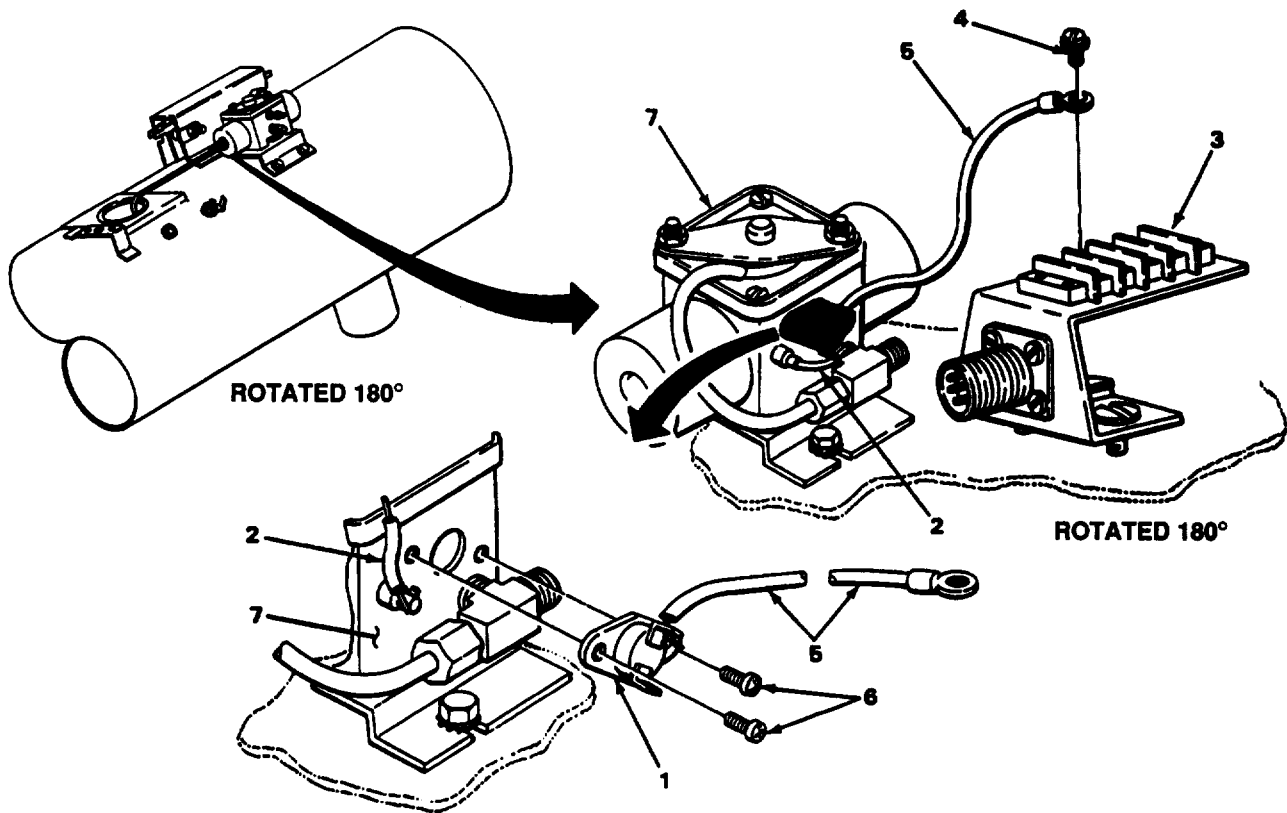

NOTE

FOLLOW-ON MAINTENANCE: install guard (page 2-42).

TASK ENDS HERE

FUEL REGULATOR VALVE - STEWART -WARNER 10560C24, 10560M; PULSED FUEL METERING VALVE, 10560M24B1, 10560G

This task covers:

Service

INITIAL SETUP

Tools

Tool Kit, Mechanics Gen (Item 1, Appendix B)

Equipment Condition

Guard removed (page 2-42).

Materials/Parts

Container, glass, 1/2-gallon,
Hose, plastic, 5/32-inch, 1. D., 8-inch

LOCATION	ITEM	ACTION	REMARKS
----------	------	--------	---------

SERVICE

NOTE

This service procedure applies to both fuel regulator valve and pulsed fuel metering valve. Fuel regulator valve shown.

1. Flame detector switch (1)	Screw (2) and wire lead (3)	Unscrew and take off lead (3), marked "NO" from igniter control to flame detector switch.
2. Regulator valve (4)	Bleeder valve (5)	<ul style="list-style-type: none"> a. Unscrew part way. b. Put one end of hose on bleeder valve (5) and the other end in glass container. c. Hold RUN/OFF/START switch at START. d. Let fuel run steady into glass container until it is clear and bubble free. e. Place RUN/OFF/START switch in OFF position. f. Take hose off bleeder valve (5). g. Screw in and tighten. h. Discard fuel in container.
3. Flame detector switch (1)	Screw (2) and wire lead (3)	Screw in and tighten.

FUEL REGULATOR VALVE - STEWART -WARNER 10560C24, 10560M; PULSED FUEL METERING VALVE, 10560M24B1, 10560OG - Continued

LOCATION	ITEM	ACTION	REMARKS
----------	------	--------	---------

SERVICE - Continued

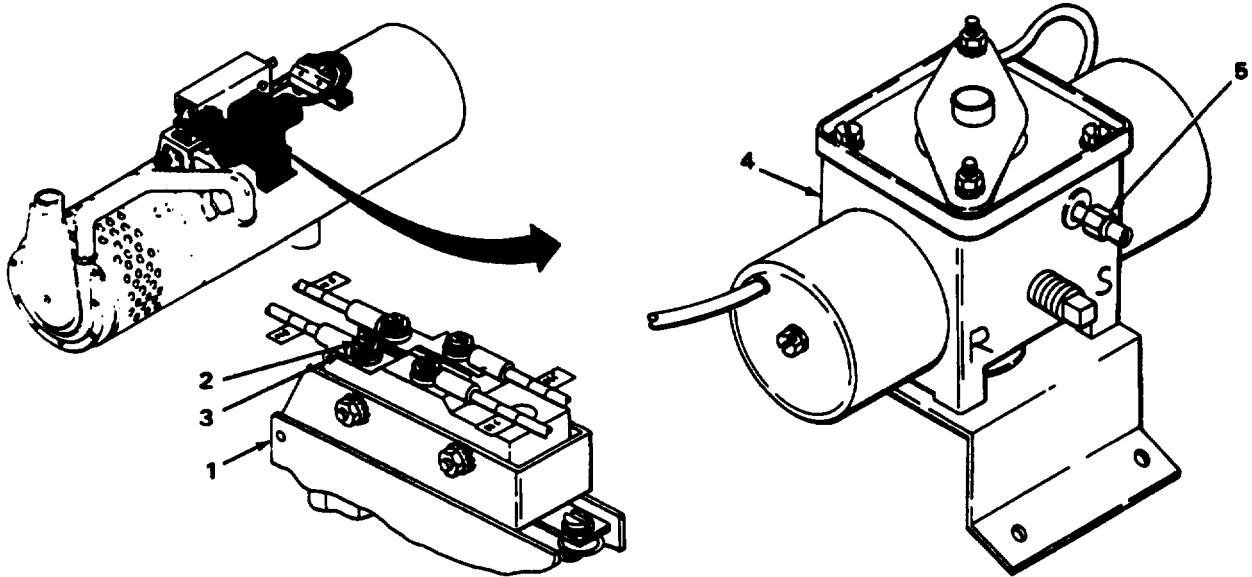

NOTE

FOLLOW-ON MAINTENANCE: Install guard (page 2-42).

TASK ENDS HERE

Section VII. START-UP AND SHUT-DOWN PROCEDURES

	Page		Page
General	2-59	Start-Up Procedure - Hupp	
Shut-Down Procedure - Stewart-		Heaters	2-60
Warner, Hupp, and ESPAR		Start-Up Procedure - Stewart-	
Heaters .,	2-61	Warner Heaters	2-59
Start-Up Procedure - ESPAR V7S	2-61		

GENERAL

STEWART-WARNER, HUPP, AND ESPAR HEATERS

This section is provided to give you Information on how to start personnel heaters. Follow these steps exactly as they appear, otherwise the heater may become flooded or parts in the ignition system maybe damaged.

START-UP PROCEDURE - STEWART-WARNER HEATERS

LOCATION	ITEM	ACTION	REMARKS
----------	------	--------	---------

CAUTION

Do not hold RUN/OFF/START switch for longer than time limits given. Damage to heater can result by burning out igniter or igniter control register.

1. Check that heater master switch is on.
2. Press PRESS TO TEST switch to check for power. Indicator light should come on.
3. Hold RUN/OFF/START switch at START for not longer than two minutes or until indicator light comes on. Indicator light will come on when heater starts.
If heater starts, go to step 6.
4. Place RUN/OFF/START switch to OFF position, and wait ten seconds. Indicator light will come on when heater starts.
1. If heater does not start, repeat steps 4 and 5.
5. Hold RUN/OFF/START switch to START for not longer than one minute or until indicator light comes on. **2. If heater does not start after repeating steps 4 and 5, troubleshoot (page 2-15).**
6. Place RUN/OFF/START switch in RUN position.

TASK ENDS HERE

START-UP PROCEDURE - HUPP HEATERS

LOCATION	ITEM	ACTION REMARKS
----------	------	-------------------

CAUTION

Do not hold RUN/OFF/START switch for longer than time limits given. Damage to heater can result by burning out igniter or igniter control register.

- | | |
|---|--|
| 1. Check that heater master switch is on. | |
| 2. Press PRESS TO TEST switch to check for power. | Indicator light should come on. |
| 3. Hold RUN/OFF/START switch at START for not longer than four minutes or until indicator light comes on. | Indicator light will come on when heater starts.
If heater starts, go to step 6. |
| 4. Place RUN/OFF/START switch in OFF position, and wait 15 minutes. | |
| 5. Hold RUN/OFF/START switch at START for not longer than four minutes or until indicator light comes on. | Indicator light will come on when heater starts.
If heater does not start, troubleshoot (page 2-15). |
| 6. Place RUN/OFF/START switch in RUN position. | |

TASK ENDS HERE

START-UP PROCEDURE - ESPAR V7S

LOCATION	ITEM	ACTION	REMARKS
----------	------	--------	---------

NOTE

Be sure vehicle ignition switch is in ON position.

NOTE

If heater has overheated, be sure to depress the overheat reset button on the switchbox.

- | | |
|--|---|
| 1. Place function switch in HEATING position. | Heater will start if ignition is successful or shut itself off if ignition does not occur within 3 minutes.
If heater runs, go to step 3. |
| 2. Place function switch in OFF position momentarily, and then return to HEATING position. | Results will be the same as for step 1.
If heater shuts down again, notify Direct Support Maintenance. |
| 3. Adjust temperature selector knob for desired outlet temperature. | |

TASK ENDS HERE

SHUT-DOWN PROCEDURE - STEWART-WARNER, HUPP, AND ESPAR HEATERS

LOCATION	ITEM	ACTION	REMARKS
----------	------	--------	---------

NOTE

It takes 1 -1/2 to 2-1/2 minutes for frame switch to cool down to trip, permitting excess fuel to vaporize and purge heat exchanger of unburned gases.

- | | |
|--|--|
| Place RUN/OFF/START switch or function switch in OFF position. | After switch has been turned to OFF position, the blower motor will continue to run, purging the remaining fuel in the heater. When all fuel has been burned and heater cooled down, the indicator light will go out and blower motor will shut off. |
|--|--|

TASK ENDS HERE

CHAPTER 3

DIRECT SUPPORT AND GENERAL SUPPORT MAINTENANCE

OVERVIEW

This chapter contains all of the maintenance authorized to be performed by Direct Support and General Support Maintenance. Included is information covering Repair Parts, Special Tools; Test, Measurement and Diagnostic Equipment (TMDE); and Support Equipment, Troubleshooting, Direct Support and General Support Maintenance instructions, and testing requirements for all the personnel heaters covered in this TM.

		Page
Section I.	Repair Parts, Special Tools; Test, Measurement and Diagnostic Equipment (TMDE); and Support Equipment	3-1
Section II.	Direct Support and General Support Troubleshooting Procedures	3-2
Section III.	Direct Support and General Support Maintenance Procedures	3-26
Section IV.	Direct Support and General Support Test Procedures	3-192

Section 1. REPAIR PARTS, SPECIAL TOOLS; TEST, MEASUREMENT AND DIAGNOSTIC EQUIPMENT (TMDE); AND SUPPORT EQUIPMENT

		Page			Page
Common Tools and Equipment	3-1	Special Tools, TMDE, and Support Equipment	3-1		
Repair Parts	3-1				

COMMON TOOLS AND EQUIPMENT

For authorized common tools and equipment, refer to the Modified Table of Organization and Equipment (MTOE) that applies to your unit.

SPECIAL TOOLS, TMDE, AND SUPPORT EQUIPMENT

Heater test stand, model VHTS-89102 is required to maintain the heater. See TM 9-4910-755-13&P,

REPAIR PARTS

Repair parts are listed and illustrated in appendix D of this manual.

Section II. DIRECT SUPPORT AND GENERAL SUPPORT TROUBLESHOOTING PROCEDURES

	Page		Page
Espar V7S Wiring Diagram	3-25	Symptom Index	3-2
Explanation of Columns	3-2	Troubleshooting	3-3
Introduction	3-2		

INTRODUCTION

This section contains information about locating and correcting most problems reported by Organizational Maintenance. It covers components that are authorized for repair or replacement at the Direct Support Maintenance level.

EXPLANATION OF COLUMNS

MALFUNCTION	Visual or operational indication that something is wrong with the heater.
TEST/inspection	Procedure to isolate the problem to a component or system.
CORRECTIVE ACTION	Procedure to correct problem.

SYMPTOM INDEX

This symptom index is provided as a quick way to get you to the part of the troubleshooting table that will help you solve the problem you are having. It lists all the malfunctions covered in the Direct Support and General Support troubleshooting table.

SYMPTOM	HUPP MF510B M F 5 1 0 C MF60A-24V MF60B-24V	S-W 10560C24 10560M 10560M24B1 10560G	ESPAR V7S
Heater Does Not Start	3-3	3-11	
Heater Does Not Start Below 40°F(4°C)	3-7	3-7	
Heater Does Not Shut Off	3-10	3-15	
Heater Output Too Low	3-8	3-16	3-21
Heater Smokes or Bangs while Starting	3-8	3-17	
Surging Combustion, or Heater Overheats and Stops Burning	3-10	3-17	
Heater Does Not Energize			3-18
Heater Does Not Ignite (Goes Out After 3 Minutes)			3-19
Heater Overheated			3-22
Heater Does Not Switch Off After Purge Cycle			3-22
Heater Operates On Half-Rated Output After 3 Minutes			3-22
Temperature Of Output Heating Air Too High			3-23
Heater Emits Soot And Heavy Smoke			3-23

TROUBLESHOOTING

HUPP MF510B, MF510C, MF60A-24V, MF60B-24V

MALFUNCTION

TEST OR INSPECTION

CORRECTIVE ACTION

1. HEATER DOES NOT START

NOTE

Igniter and flame detector switch test good or have been replaced.

CAUTION

Multimeter must be set for dc voltage measurements before performing steps 2 and 3. Damage to multimeter may result.

Step 1. Set multimeter for dc voltage measurements.

Step 2. Remove guard (page 2-32).

Step 3. With an ohmmeter, check the resistance of the igniter to the ground. If OPEN, replace igniter; if igniter resistance is 4 ohms or more, igniter function is OK. Set multimeter for DC voltage measurements. Turn heater to START; measure voltage from igniter to ground. If voltage is 20-24VDC, the voltage regulator is OK. If reading is outside acceptable range, replace voltage regulator.

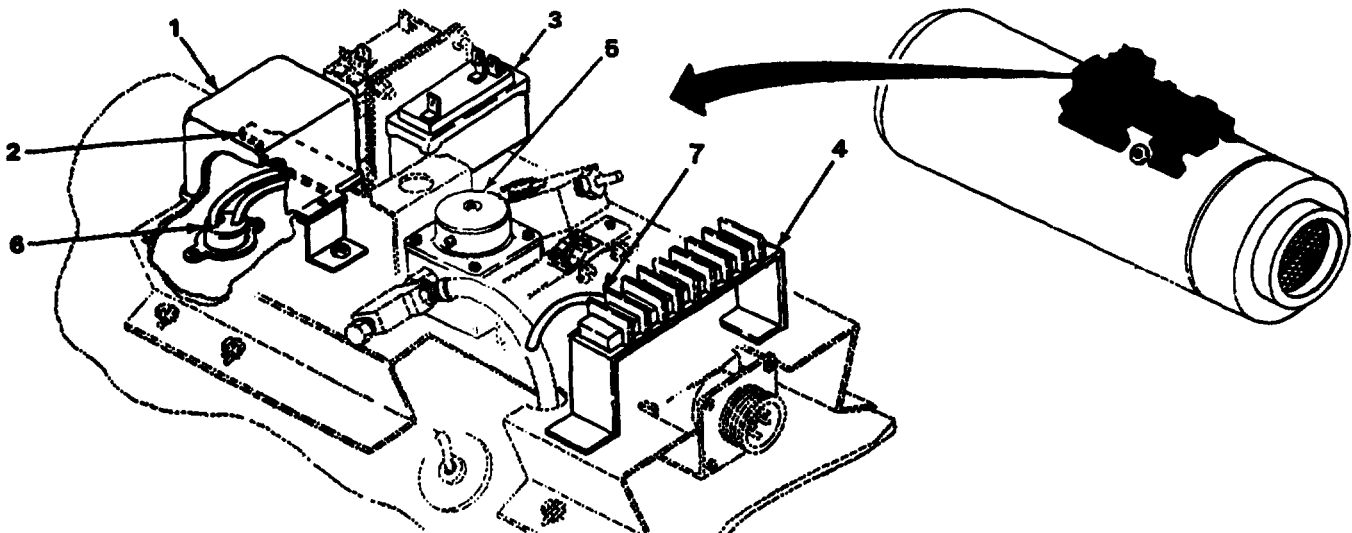

Step 4. Check for defective igniter relay/power control (1) by starting heater (page 2-60) and placing red multimeter probe on output terminal E (2) and black probe on ground.

a. If multimeter reading on MF510B heater is less than 19 volts or more than 26 volts, replace igniter relay (page 3-41).

b. If multimeter readings on MF510C, MF60A-24V, and MF60B-24V heaters are less than 17 volts or more than 18 volts, replace power control (page 3-43).

TROUBLESHOOTING-CONTINUED

HUPP MF510B, MF510C, MF60A-24V, MF60B-24V - CONTINUED

MALFUNCTION
 TEST OR INSPECTION
 CORRECTIVE ACTION

NOTE

If multimeter reading exceeded the limits, also replace the igniter (page 2-35).

1. HEATER DOES NOT START-CONTINUED

Step 5. Check for defective valve relay (3) by connecting a jumper wire between terminals 1 and 7 of terminal strip (4) and placing red multimeter probe on terminal 7 of terminal strip (4) and black probe on ground.

If there is no voltage present on terminal 7, replace valve relay (page 3-32).

Step 6. Set multimeter for resistance measurements.

Step 7. Check for defective shut-off solenoid (5) by disconnecting solenoid lead 7 (7) from terminal 7 of terminal strip(4) and placing red multimeter probe on lead 7 (7) and black probe on ground.

If multimeter reading is less than 80 ohms or more than 100 ohms, replace fuel regulator valve (page 3-47).

Step 8. Remove flame detector switch, and check for obvious signs of damage (page 2-33).

Replace if necessary (page 2-33).

Step 9. Check for defective overheat switch (6) by placing red multimeter probe on terminal 1 and black probe on terminal 7 of terminal strip (4).

If multimeter reading is one ohm or more, replace overheat switch (page 3-57).

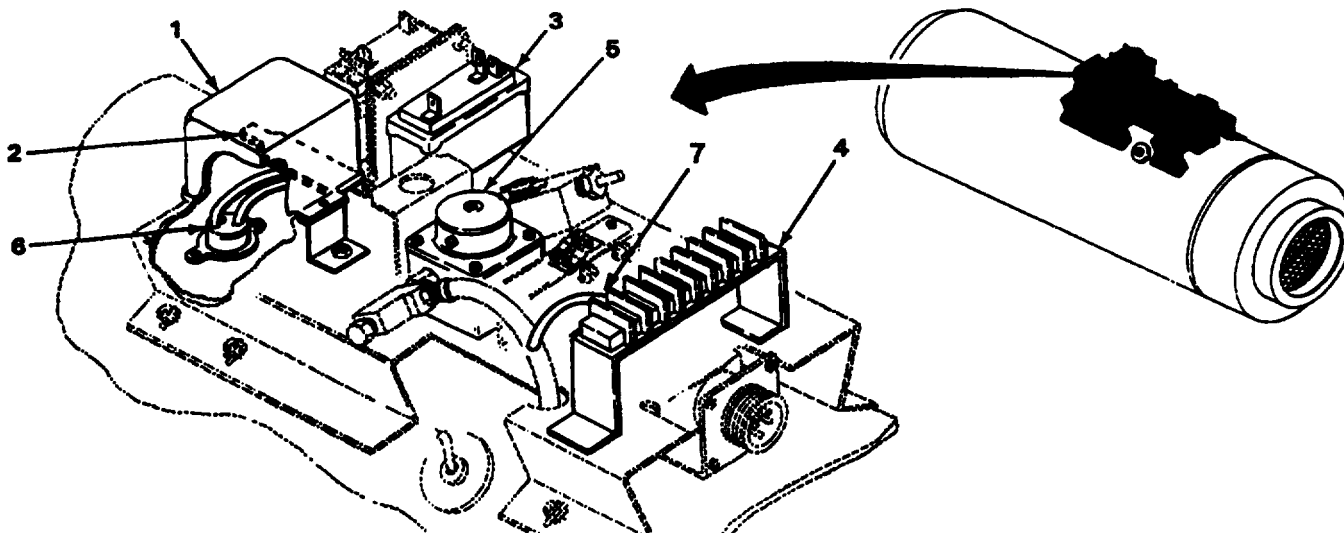

TROUBLESHOOTING-CONTINUED

HUPP MF510B, MF510C, MF60A-24V, MF60B-24V - CONTINUED

MALFUNCTION	TEST OR INSPECTION	CORRECTIVE ACTION
-------------	--------------------	-------------------

1, HEATER DOES NOT START-CONTINUED

Step 10. Remove fuel nozzle and position container to catch fuel. Place jumper wire between terminal No. 3 and No. 7 on terminal board. Place heater control switch on control box panel to START. If fuel flows, turnoff heater; clean or replace nozzle. If fuel does not flow, clean remote filter, replace regulator valve, or inspect fuel pump. Adjust if necessary.

Step 11. Check for defective burner thermostat/preheater.

a. Disconnect burner thermostat leads (1) and (2) from terminals 1 and 3 of terminal strip (3).

b. Place one multimeter probe on each burner thermostat lead (1) and (2).

If multimeter indicates continuity, replace burner thermostat/preheater (page 3-58).

c. Start heater (page 2-60), and watch for multimeter reading change.

If multimeter reading does not fall to zero ohms within 3 minutes replace burner thermostat/preheater. If burner thermostat does not close in 3 minutes, the burner thermostat maybe OK if the preheater is bad.

Step 12. Check for defective preheater by placing red multimeter probe on terminal 6 of terminal strip (3) and black probe on ground.

If multimeter reading is greater than 20 ohms, replace preheater (page 3-58).

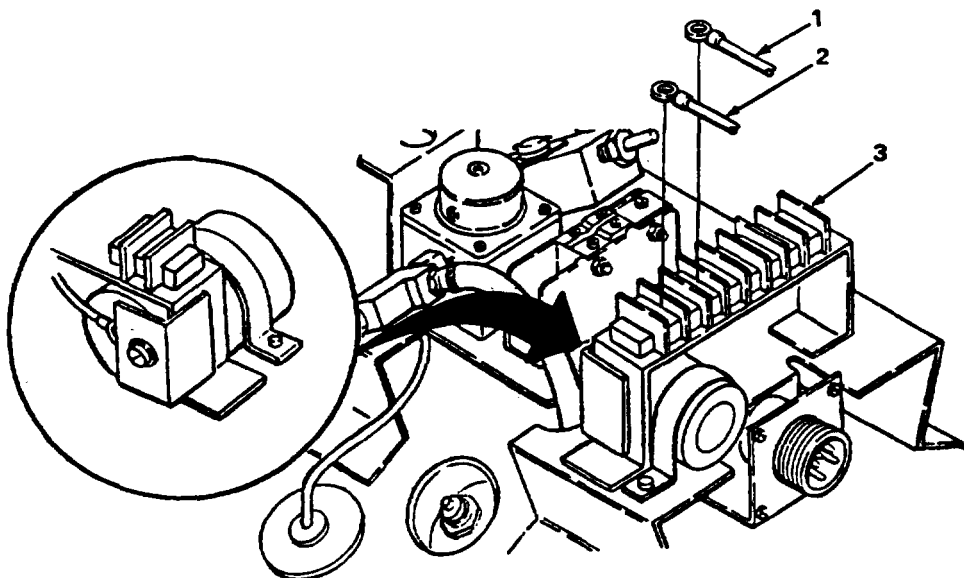

TROUBLESHOOTING-CONTINUED

HUPP MF510B, MF510C, MF60A-24V, MF60B-24V - CONTINUED

MALFUNCTION

TEST OR INSPECTION

CORRECTIVE ACTION

1, HEATER DOES NOT START-CONTINUED

Step 13. Check for defective capacitor. Remove wire 8 (4) from terminal 8 and place red multimeter probe on wire 8 (4) while placing black multimeter probe on capacitor ground screw (5). If reading is one ohm or more, replace capacitor (page 3-39).

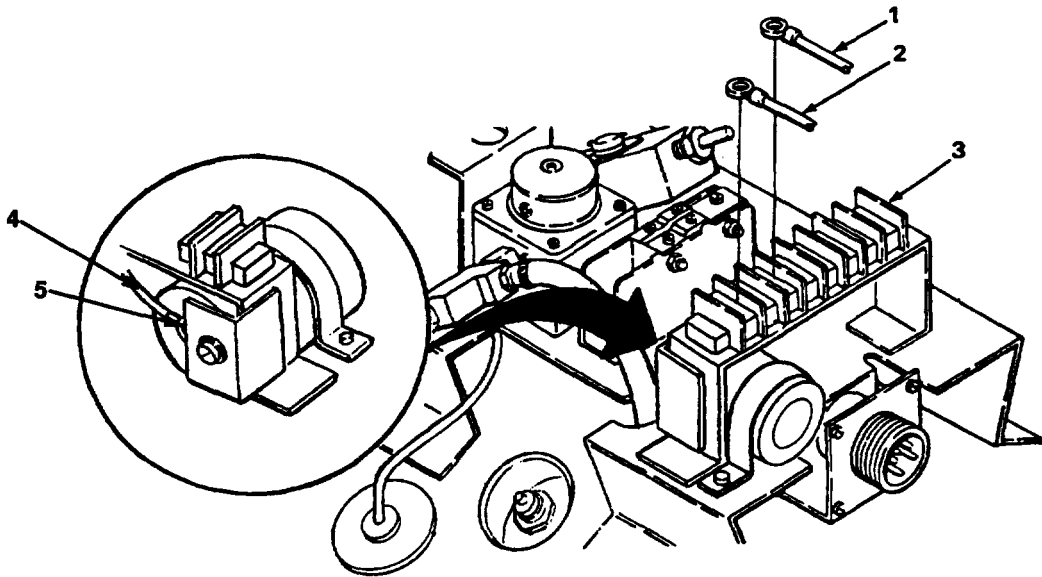

Step 14. Check for defective blower motor by placing red multimeter probe on terminal 8 of terminal strip (3) and black probe on ground.

If multimeter reading is greater than 0.5 ohms, replace blower motor (page 3-62).

Step 15. Check for defective flame detector switch resistor by placing red multimeter probe on common terminal of flame detector switch (6) and black probe on terminal 8 of terminal strip (3).

If multimeter reading is less than 7 ohms or more than 9 ohms, replace flame detector switch (page 2-33).

TROUBLESHOOTING-CONTINUED**HUPP MF510B, MF510C, MF60A-24V, MF60B-24V - CONTINUED**

MALFUNCTION

TEST OR INSPECTION

CORRECTIVE ACTION

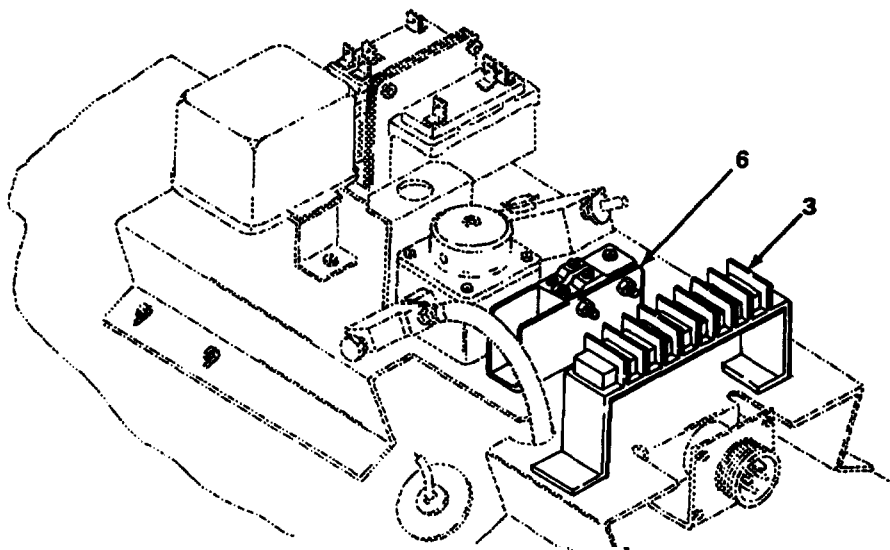
1. HEATER DOES NOT START-CONTINUED

Step 16. Remove burner plate, and inspect it (page 3-60).

- a. If burner is carbon fouled, clean burner plate (page 3-60).
- b. If burner plate is damaged, replace (page 3-61).

Step 17. Start heater (page 2-59).

- a. If heater starts, install guard (page 2-32).
- b. If heater does not start, replace heater.

2. HEATER DOES NOT START BELOW 40°F (4°C)

Step 1. Remove guard (page 2-32).

TROUBLESHOOTING-CONTINUED

HUPP MF510B, MF510C, MF60A-24V, MF60B-24V - CONTINUED

MALFUNCTION

TEST OR INSPECTION

CORRECTIVE ACTION

2. HEATER DOES NOT START BELOW 40°F (4°C) -CONTINUED

Step 2. Check for defective heating elements in fuel regulator valve (1) and reservoir (2) as fol-

- a. Disconnect all three heating element leads (3) from terminal 5 on terminal strip (4).
- b. Measure resistance of each heating element by placing red multimeter probe on heating element lead (3) and black probe on ground.
 1. If any multimeter reading is less than 10 ohms or greater than 20 ohms, replace fuel regulator valve (page 3-47).
 2. If all multimeter readings are within limits, replace heater.

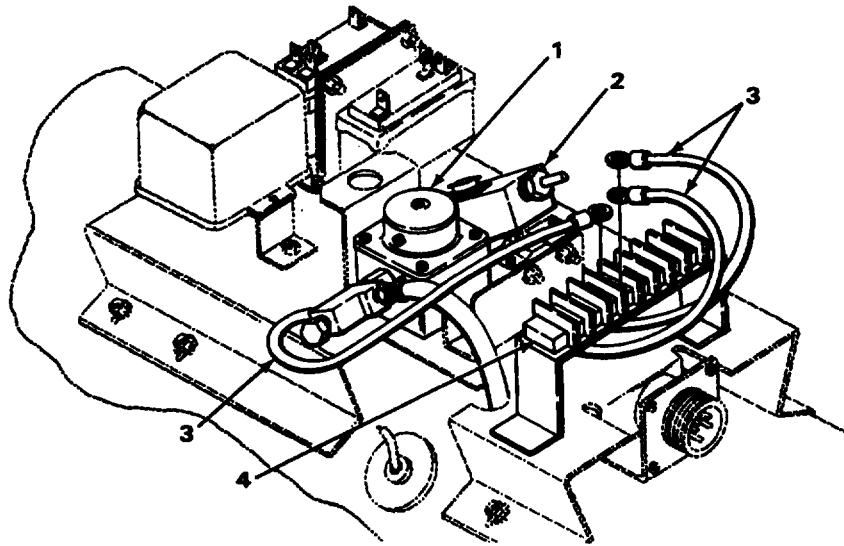

3. HEATER SMOKES OR BANGS WHILE STARTING

Step 1. Check for defective blower motor (step 12, malfunction 1).

Step 2. Check for defective flame detector switch (step 13, malfunction 1).

Step 3. Check for defective burner plate or combustion chamber (step 14, malfunction 1).

4. HEATER OUTPUT TOO LOW

Step 1. Remove guard (page 2-32).

Step 2. Clean, and inspect fuel regulator valve (page 3-47).

TROUBLESHOOTING-CONTINUED

HUPP MF510B, MF510C, MF60A-24V, MF60B-24V - CONTINUED

MALFUNCTION

TEST OR INSPECTION

CORRECTIVE ACTION

4. HEATER OUTPUT TOO LOW-CONTINUED

Step 3. Check for defective HI/LO pressure regulator in fuel regulator valve (1) as follows:

- a. Disconnect HI/LO pressure regulator lead (5) from terminal 4 of terminal strip (4).
- b. Place red multimeter probe on HI/LO pressure regulator lead (5) and black probe on ground.

If multimeter reading is less than 70 ohms or greater than 110 ohms, replace fuel regulator valve (page 3-47).

Step 4. Check for defective HI/LO fire relay (6) as follows:

- a. Set multimeter for dc voltage measurements.
- b. Start heater (page 2-60).
- c. Place red multimeter probe on terminal 4 of terminal strip (4) and black probe on ground.

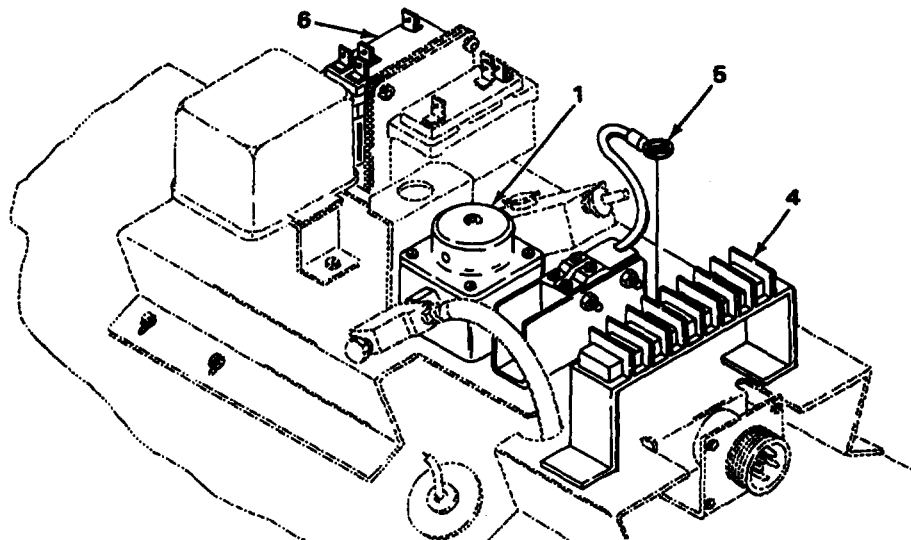

- d. Switch heater back and forth between HI and LO operation.

If multimeter reading does not change back and forth between zero volts supply voltage value, replace HI/LO fire relay (page 3-30).

TROUBLESHOOTING-CONTINUED

HUPP MF510B, MF510C, MF60A-24V, MF60B-24V - CONTINUED

MALFUNCTION	TEST OR INSPECTION	CORRECTIVE ACTION
-------------	--------------------	-------------------

4. HEATER OUTPUT TOO LOW - CONTINUED

Step 5. Check fuel regulator valve for adequate fuel delivery (page 3-55).

Adjust if necessary (page 3-53).

Step 6. Test heater (page 3-193).

a. If heater output is still too low, replace heater.

b. If heater output is normal, install guard (page 2-32).

5. SURGING COMBUSTION, OR HEATER OVERHEATS AND STOPS BURNING

Step 1. Check for defective overheat switch (step 8, malfunction 1).

Step 2. Check fuel regulator valve for proper fuel delivery (page 3-55).

Adjust if necessary (page 3-53).

Step 3. Clean fuel nozzle (page 2-39).

Step 4. Check for defective valve relay (step 4, malfunction 1).

Step 5. Test heater (page 3-193).

If heater still does not run properly, replace heater.

6. HEATER DOES NOT SHUT OFF

NOTE

Flame detector switch contacts test good or switch has been replaced.

Check flame detector switch for obvious signs of damage (step 7, malfunction 1).

TROUBLESHOOTING - CONTINUED

STEWART-WARNER 10560C24, 10560M, 10560M24B1, 10560G

MALFUNCTION	TEST OR INSPECTION	CORRECTIVE ACTION
-------------	--------------------	-------------------

1. HEATER DOES NOT START

NOTE

Igniter, ignition control, flame detector switch, and overheat switch test good or have been replaced.

Step 1. Remove guard (page 2-42).

Step 2. Check shut-off solenoid (1) as follows:

- a. Start heater (page 2-59).
- b. Using multimeter set for resistance, put red probe on terminal (2) and black probe to good ground.

If multimeter reading is not 130-140 ohms, replace solenoid(1) (10560C24, 10560M and 10560G, page 3-74; 10560M24B1, page 3-88).

- c. Turn off heater (page 2-61).

Step 3. Check for proper igniter voltage as follows:

- a. Set multimeter for dc voltage measurements.
- b. Place red multimeter probe on output terminal of ignition control (3) and black probe on ground.
- c. Start heater (page 2-59).

If multimeter reading is more than 12.0 volts, replace voltage limiter assembly (10560C24, 10560G, page 3-1 14; 10560M, 10560M24B1, page 3-1 16).

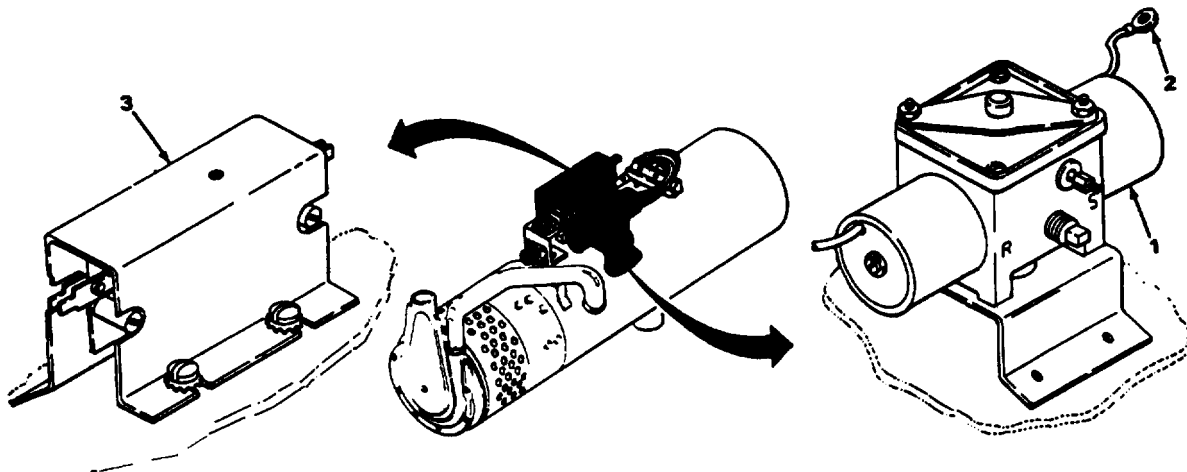

TROUBLESHOOTING-CONTINUED

STEWART- WARNER 10560C24, 10560M, 10560M24B1, 10560G - CONTINUED

MALFUNCTION	TEST OR INSPECTION	CORRECTIVE ACTION
-------------	--------------------	-------------------

1. HEATER DOES NOT START-Continued

Step 4. Check for proper fuel flow (10560C24,10560M,10560G, page 3-74; 10560M24B1, page 3-88).

Adjust if necessary (page 3-84 and 3-96).

Step 5. Check wick (1) as follows:

- a. Remove igniter (2)(page 2-49).
- b. Visually inspect wick (1) for carbon buildup or burn damage by shining flash-light down tube.

If wick (1) is burned away or filled with carbon, repair burner (page 3-131).

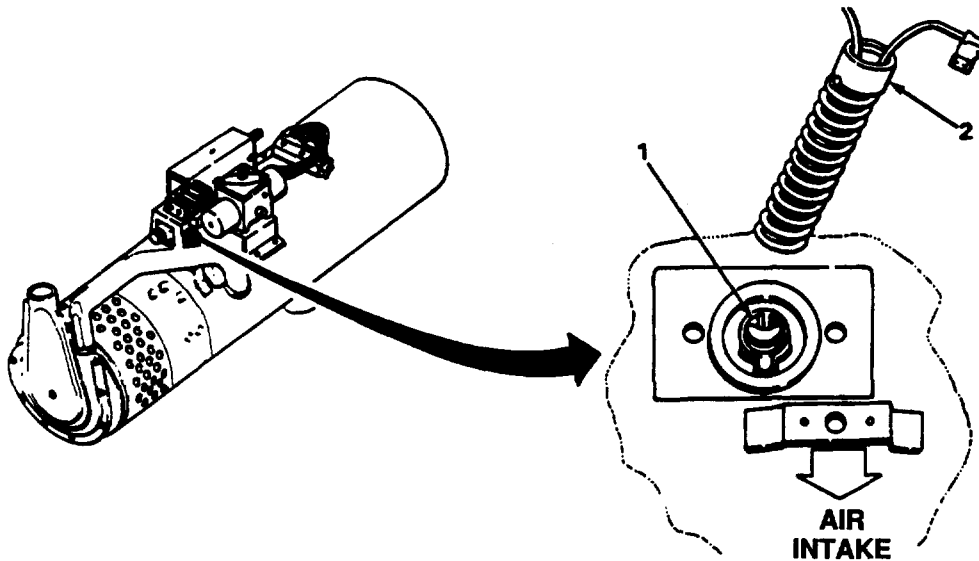

TROUBLESHOOTING-CONTINUED

STEWART- WARNER 10560C24, 10560M, 10560M24B1, 10560G - CONTINUED

MALFUNCTION	TEST OR INSPECTION	CORRECTIVE ACTION
-------------	--------------------	-------------------

1. HEATER DOES NOT START-Continued

Step 6. Check blower motor (3) as follows:

- a. Remove blower assembly (10560C24 and 10560G, page 3-99; 10560M and 10560M24B1, page 3-105).
- b. Remove motor subassembly (10560M and 10560M24B1 only, page 3-105).
- c. Take out two screws (4) holding semiconductor device/diode mounting assembly (5) to case of blower assembly (6) (10560C24 and 10560G).
- d. Disconnect motor lead (7) from semiconductor device diode mounting assembly output terminal (8).
- e. Place red multimeter probe on motor lead (7) and black probe on case of blower motor (3).
 1. If multimeter reading is greater than 0.5 ohms, replace blower motor (10560C24 and 10560G, page 3-99; 10560M and 10560M24B1, page 3-105).
 2. If multimeter reading is less than 0.5 ohms, go on to step 7. Do not reinstall blower assembly or motor subassembly at this time.

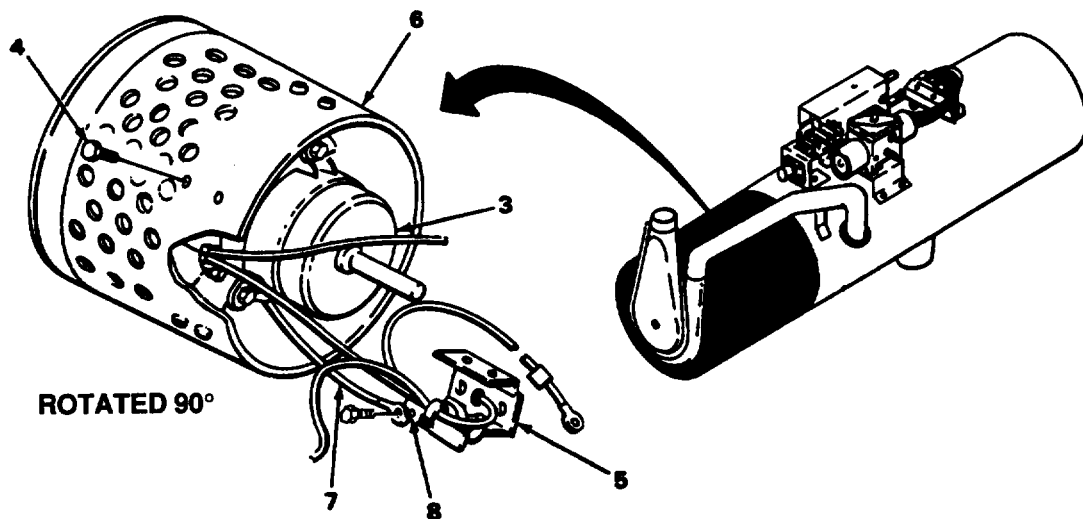

TROUBLESHOOTING-CONTINUED

STEWART- WARNER 10560C24, 10560M, 10560M24B1, 10560G - CONTINUED

MALFUNCTION	TEST OR INSPECTION	CORRECTIVE ACTION
-------------	--------------------	-------------------

1. HEATER DOES NOT START-Continued

Step 7. Check semiconductor device/diode mounting assembly (1) as follows:

- a. Set multimeter for resistance measurements.
- b. Place red multimeter probe on output terminal (2) and black probe on un-marked lead (3). Note multimeter reading.
- c. Reverse multimeter probes, and note reading.

One multimeter reading should be high and the other low. If both are high or both are low, replace semiconductor device/diode mounting assembly (10560C24 and 10560G, page 3-120; 10560M and 10560M24B1, page 3-122).

- d. Place red multimeter probe on output terminal (2) and black probe on lead.4. Note multimeter reading.
- e. Reverse multimeter leads, and note reading.

One multimeter reading should be high and the other low. If both are high or both are low, replace semiconductor device/diode mounting assembly (10560C24 and 10560G, page 3-120; 10560M and 10560M24B1, page 3-122).

- f. Place red multimeter probe on output terminal (2) and black probe on case of blower motor (4). Note multimeter reading.
- g. Reverse multimeter leads. Note multimeter reading.

One multimeter reading should be high and the other low. If both are high or both are low, replace semiconductor device/diode mounting assembly (10560C24 and 10560G, page 3-120; 10560M and 10560M24B1, page 3-122).

- h. Reattach motor lead (5) to output terminal (2).
- i. Reattach semiconductor device/diode mounting assembly (1) to case of blower assembly (6) with screw (7) (10560C24 and 10560G only).
- j. Install motor subassembly (10560M and 10560M24B1 only, page 3-11 1).

Step 8. Remove, and inspect burner assembly (10560C24 and 10560G, page 3-125; 10560M and 10560M24B1, page 3-1 27).

- a. If burner assembly is full of carbon, repair (page 3-131).

TROUBLESHOOTING-CONTINUED

STEWART- WARNER 10560C24, 10560M, 10560M24B1, 10560G - CONTINUED

MALFUNCTION	
TEST OR INSPECTION	
	CORRECTIVE ACTION

1. HEATER DOES NOT START-Continued

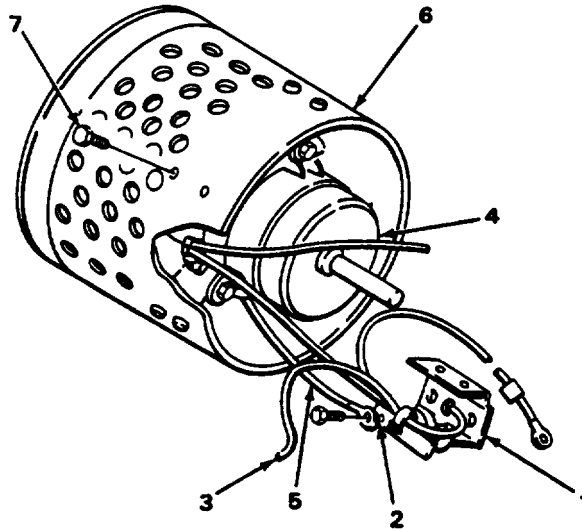

b. If burner assembly shows signs of burn damage, replace (10560C24 and 10560G, page 3-125; 10560M and 10560M24B1, page 3-127).

Step 9. Test heater (page 3-193).

- a. If heater still does not start, replace heater.
- b. If heater starts, install guard (page 2-42).

2. HEATER DOES NOT SHUTOFF

NOTE

Flame detector switch continuity and adjustment are good.

Step 1. Disassemble flame detector switch, and inspect for defective rod or tube (page 3-72), and make sure that it is properly adjusted (page 2-43).

Replace if necessary (page 2-43).

Step 2. Test heater (page 3-193).

If heater still does not shut off, replace switch (page 2-43).

TROUBLESHOOTING-CONTINUED

STEWART-WARNER 10560C24, 10560M, 10560M24B1, 10560G - CONTINUED

MALFUNCTION
TEST OR INSPECTION
CORRECTIVE ACTION

3. HEATER OUTPUT TOO LOW

Step 1. Remove guard (page 2-42).

Step 2. Clean and inspect fuel regulator valve (page 3-74).

Step 3. Check restriction solenoid (1) as follows (10560C24, 10560G and 10560M only):

a. Start heater (page 2-59).

b. Using multimeter set for resistance, put red probe on terminal (2) and black probe to good ground.

If multimeter reading is not 130-140 ohms, replace restriction solenoid (page 3-74).

Step 4. Check for proper fuel delivery during HI operation (10560C24, 10560G and 10560M, page 3-84; 10560M24B1, page 3-96).

Adjust if necessary (page 3-84 and 3-96).

Step 5. Remove and inspect burner assembly (malfunction 1), step 8.

Step 6. Test heater (page 3-193).

a. If heater output is still too low, replace heater.

b. If heater output is normal, install guard (page 2-42).

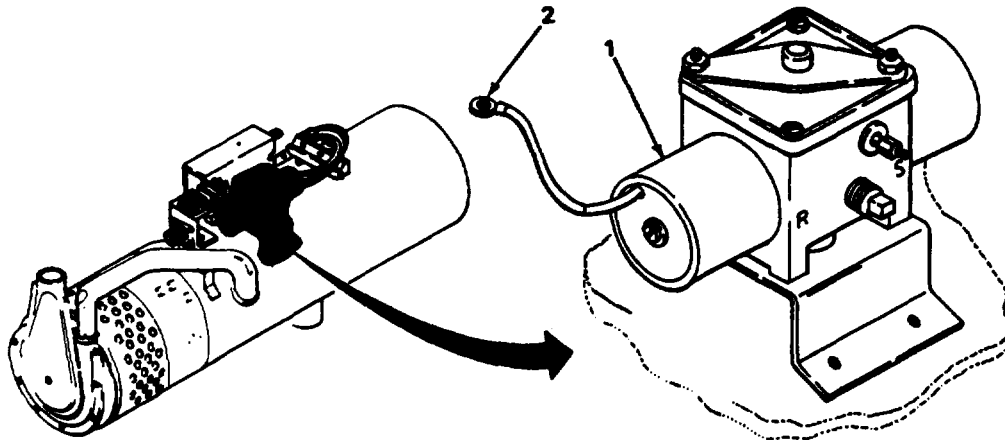

TROUBLESHOOTING-CONTINUED**STEWART- WARNER 10560C24, 10560M, 10560M24B1, 10560G - CONTINUED**

MALFUNCTION	TEST OR INSPECTION	CORRECTIVE ACTION
-------------	--------------------	-------------------

4. HEATER SMOKES OR BANGSWHILE STARTING

Step 1. Check for proper fuel delivery during HI operation (10560C24, 10560G and 10560M, page 3-74; 10560M24B1, page 3-88).

Adjust if necessary (page3-74 and 3-88).

Step 2. Test heater (page 3-192).

If heater still is not running properly, replace heater.

Step 3. Remove and inspect burner (malfunction 1), step 8.

5. SURGING COMBUSTION, OR HEATER OVERHEATS AND STOPS BURNING**NOTE**

Overheat switch tests good or has been replaced (page 3-146).
Fuel delivery on the 10560M24B1, pulsed fuel metering valve will pulse.

Step 1. Check fuel regulator valve 10560C24 and 10560M (page 3-74) and pulsed fuel metering valve, 10560M24B1, 10560G (page 3-88) for steady fuel delivery.

a. If fuel delivery rate is unsteady, replace fuel regulator valve (10560C24 and 10560M, (page 3-74); pulsed fuel metering valve 10560M24B1 and 10560G (page 3-88).

b. If fuel delivefy rate is steady, replace heater.

TROUBLESHOOTING-CONTINUED

ESPAR V7S

MALFUNCTION
 TEST OR INSPECTION
 CORRECTIVE ACTION

1. HEATER DOES NOT ENERGIZE

NOTE

Heater will shut down automatically if vehicle voltage drops below 21 volts. If heater does not start in three minutes, start switch will automatically shut off.

Step 1. Check for proper voltage requirements as follows:

- a. Disconnect switchbox cable (1) to heater (2).
- b. Using multimeter set to read dc voltage, put red probe on terminal 30 and black probe on terminal 31 of switchbox cable (1).

If multimeter reads anything other than 21 volts to 28 volts, troubleshoot vehicle electrical system (refer to applicable vehicle technical manuals),

Step 2. Depress the overheat reset button (3) on the switchbox (4).

Step 3. Replace Air/Heat switch of switchbox. (refer to applicable vehicle technical manuals).

Step 4. Check switchbox cables (1) and (5) for broken, corroded, or missing terminals as follows:

- a. Disconnect switchbox cables (1) and (5) from heater (2).
- b. If corroded, broken, or missing terminals are found, clean or replace (refer to applicable vehicle technical manuals).

Step 5. Replace heat regulator (page 3-179).

If heater still does not energize, replace heater.

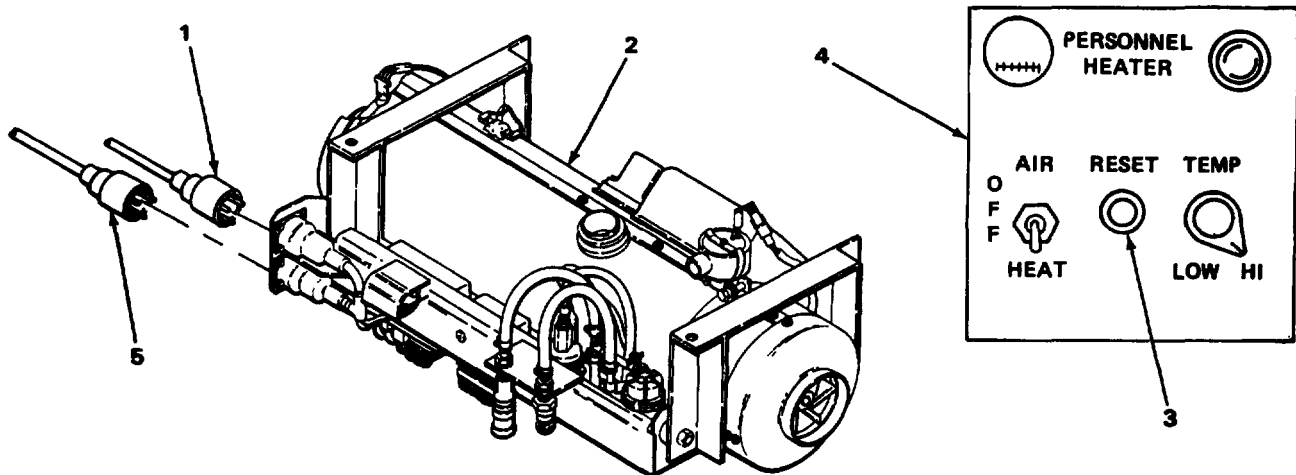

TROUBLESHOOTING-CONTINUED

ESPAR V7S - CONTINUED

MALFUNCTION	
TEST OR INSPECTION	
CORRECTIVE ACTION	

2. HEATER DOES NOT IGNITE (GOES OUT AFTER 3 MINUTES)

Step 1. Check for blocked air inlet or exhaust pipe.

Clear all passages to and from heater (refer to applicable vehicle technical manuals).

Step 2. Check for adequate fuel supply.

Troubleshoot vehicle fuel system (refer to applicable vehicle technical manuals).

Step 3. Check for defective glow plug (1) as follows:

- a. Remove hood (3-135).
- b. Remove glow plug (1) (page 3-138).
- c. Connect leads (2) to glow plug (1), and ground glow plug (1) to heater housing (3).
- d. Start heater (page 2-61).
- e. Look to see if glow plug (1) turns bright red hot.
 1. If glow plug (1) turns red hot, install (page 3-138).
Go to step 6.
 2. If glow plug (1) does not turn red hot, replace (page 3-138).
- f. Install hood (page 3-135).

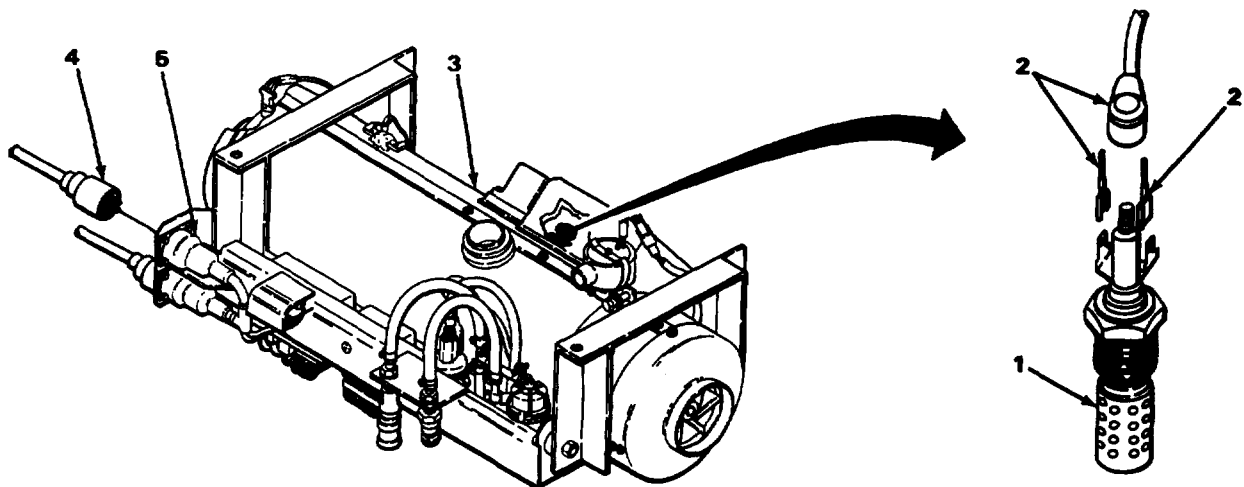

TROUBLESHOOTING-CONTINUED

ESPAR V7S - CONTINUED

MALFUNCTION	
TEST OR INSPECTION	
CORRECTIVE ACTION	

2. HEATER DOES NOT IGNITE (GOES OUT AFTER 3 MINUTES) -CONTINUED

Step 4. Replace fixed wire resistor (page 3-146).

Step 5. Replace ignition spark generator (page 3-136).

Step 6. Replace radio filter (page 3-183).

Step 7. Replace heat regulator (page 3-179).

Step 8. Replace impulse switch (page 3-181).

Step 9. Replace circulating pump (page 3-174).

Step 10. Replace fuel pump (page 3-176).

Step 11. Check for defective blower motor as follows:

- a. Disconnect switchbox cable (4) from heater (3).
- b. Apply 24-volt positive jumper lead to terminal 324 and negative jumper lead to terminal 31 of connector (5).

If blower motor does not operate, replace (page 3-185).

Step 12. Replace heater (3).

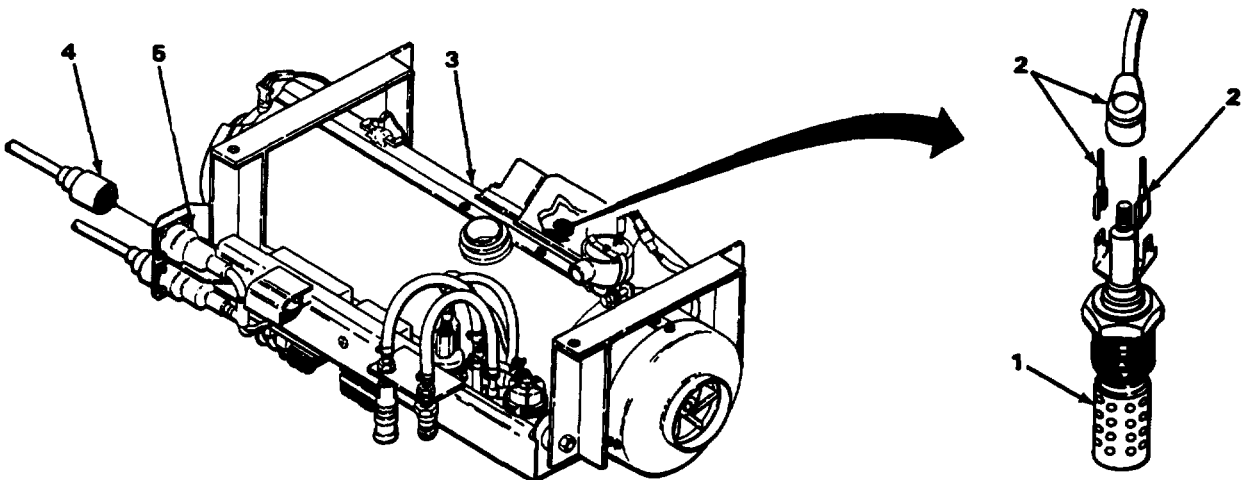

TROUBLESHOOTING-CONTINUED

ESPAR V7S - CONTINUED

MALFUNCTION
TEST OR INSPECTION
CORRECTIVE ACTION

3. HEATER OUTPUT TOO LOW

Step 1. Check all hot air ducts and hoses for cracks, damage, and proper connections (refer to applicable vehicle technical manuals).

Step 2. Check connector (1) and terminals (2) of temperature sensor (3) for a good connection.

Step 3. Check for defective temperature sensor (3) as follows:

- a. Be sure temperature sensor is at room temperature, approximately 68°F (20°C).
- b. Pull wire connector (1) off temperature sensor (3).
- c. Using multimeter set to resistance measurements, place probes on terminals (2) of temperature sensor (1).
 1. If multimeter reads between 105.5 ohms and 110.5 ohms, plug wire connector (1) onto temperature sensor (3).
 2. If multimeter does not read between 105.5 ohms and 110.5 ohms, replace temperature sensor (page 3-140).

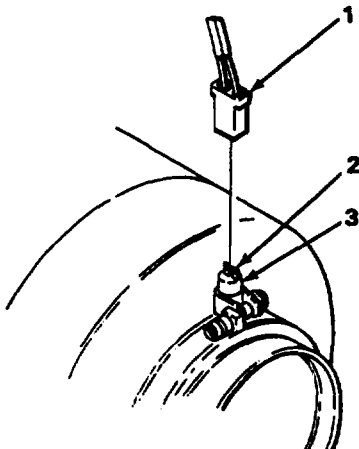

ROTATED 180°

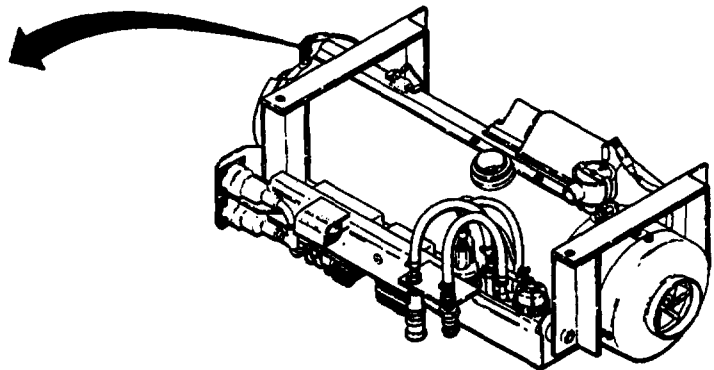

Step 4. Check switchbox for damaged temperature selector switch (refer to applicable vehicle technical manuals).

TROUBLESHOOTING-CONTINUED

ESPAR V7S - CONTINUED

MALFUNCTION	TEST OR INSPECTION	CORRECTIVE ACTION
-------------	--------------------	-------------------

3. HEATER OUTPUT TOO LOW-CONTINUED

Step 5. Check for adequate fuel supply. Troubleshoot vehicle fuel system (refer to applicable vehicle technical manuals).

Step 6. Replace circulating pump (page 3-174).

Step 7. Replace fuel pump (page 3-176).

If heater output is still too low, replace heater.

4. HEATER OVERHEATED

NOTE

In order to restart the heater after overheating has occurred, the overheat reset button on the switchbox must be depressed.

Step 1. Check for blocked air inlet, hot air outlet, or exhaust pipe.

Clear all passages to and from heater (refer to applicable vehicle technical manuals).

Step 2. Check for defective temperature sensor (step 3, malfunction 3, page 3-140).

Step 3. Check switchbox for damaged temperature selector switch (refer to applicable vehicle technical manuals).

Step 4. Replace overheat switch (page 3-148).

If heater still overheats, replace heater.

5. HEATER DOES NOT SWITCH OFF AFTER PURGE CYCLE

Step 1. Replace thermostatic switch (page 3-142).

Step 2. Replace heat regulator (page 3-179).

If heater still does not switch off after purge cycle, replace heater.

6. HEATER OPERATES ON HALF-RATED OUTPUT AFTER 3 MINUTES

Step 1. Check for defective temperature sensor (step 3, malfunction 3, page 3-140).

Step 2. Check switchbox for damaged temperature selector switch (refer to applicable vehicle — technical manuals).

If heater still operates on half rated output after 3 minutes, replace heater.

TROUBLESHOOTING-CONTINUED**ESPAR V7S - CONTINUED**

MALFUNCTION	
TEST OR INSPECTION	
CORRECTIVE ACTION	

7. TEMPERATURE OF OUTPUT HEATING AIR TOO HIGH

- Step 1. Check switchbox for damaged temperature selector switch (refer to applicable vehicle technical manuals).
- Step 2. Check for defective temperature sensor (step 3, malfunction 3, page 3-140).
- Step 3. Replace impulse switch (page 3-1 81).
- Step 4. Replace circulating pump (page 3-1 74).

If temperature of output heating air is still too high, replace heater.

8. HEATER EMITS SOOT AND HEAVY SMOKE

- Step 1. Check for proper voltage requirements (step 1, malfunction 1, page 3-18).
- Step 2. Check for blocked combustion air inlet or exhaust pipe.

Clear all passages to and from heater (refer to applicable vehicle technical manuals).

Step 3. Check for defective solenoid valve (1) as follows:

- a. Remove solenoid valve (1) (page 3-1 52).
- b. Apply battery voltage to terminals of solenoid valve(1).
 1. If solenoid valve (1) opens, install (page 3-152).
 2. If solenoid valve (1) does not open, replace (page 3-152).

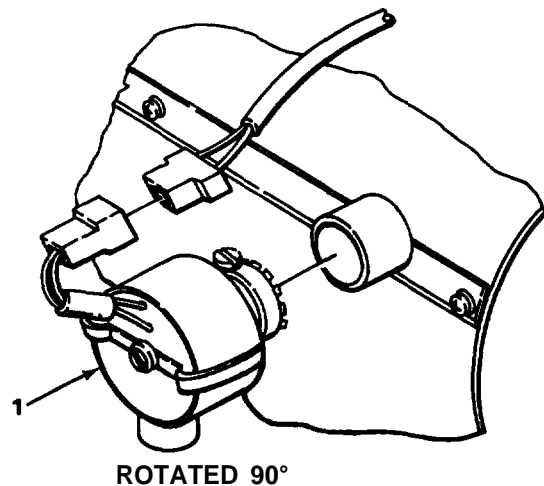
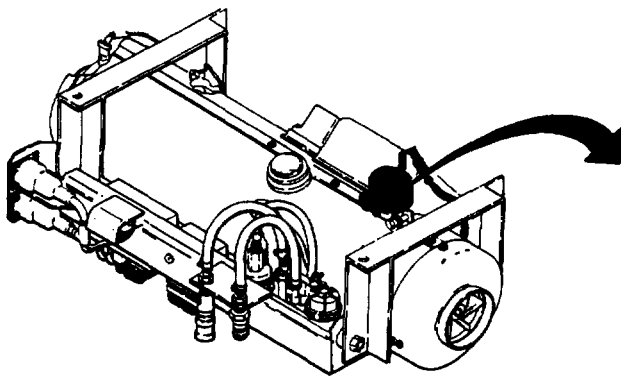

TROUBLESHOOTING-CONTINUED

ESPAR V7S - CONTINUED

MALFUNCTION	TEST OR INSPECTION	CORRECTIVE ACTION
-------------	--------------------	-------------------

8. HEATER EMITS SOOT AND HEAVY SMOKE-CONTINUED

Step 4. Replace impulse switch (page 3-181).

Step 5. Replace circulating pump (page 3-174).

Step 6. Replace blower motor (page 3-185).

If heater still emits soot and heavy smoke, replace heater.

WIRING DIAGRAM - ESPAR V7S

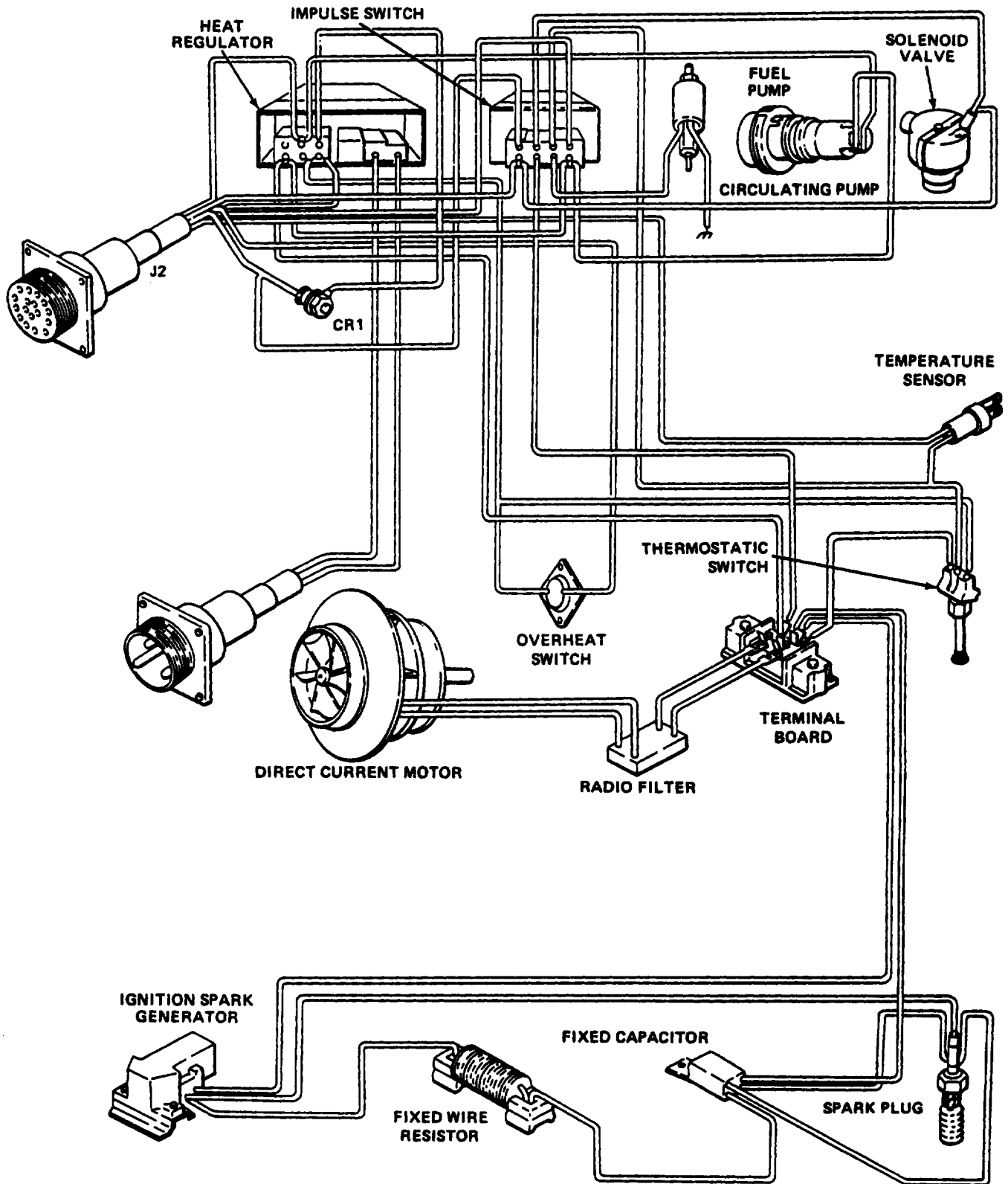

Section III. DIRECT SUPPORT AND GENERAL SUPPORT MAINTENANCE PROCEDURES

	Page		Page
Blower Assembly - Hupp MF510B, MF510C, MF60A-24V, MF60B-24V	3-62	Hi/LO Fire Relay - Hupp MF510B, MF510C, MF60A-24V, MF60B-24V	3-30
Blower Assembly - Stewart-Warner 10560C24, 10560G	3-99	Hood - Espar V7S	3-135
Blower Assembly - Stewart-Warner 10560M, 10560M24B1	3-105	Ignition Spark Generator - Espar V7S	3-136
Blower Motor and Impeller - Espar V7S	3-185	Igniter Relay - Hupp MF510B, Voltage Regulator - Hupp MF510C, MF60A-24V, MF60B-24V	3-41
Burner Assembly and Heat Exchanger - Espar V7S	3-188	Impulse Switch - Espar V7S	3-181
Burner Plate - Hupp MF510B, MF510C, MF60A-24V, MF60B-24V	3-60	Mounting Assembly - Espar V7S	3-163
Burner Repair - Stewart-Warner 10560C24, 10560M, 10560G, 10560M24B1	3-131	Overheat Switch - Espar V7S	3-148
Burner Replacement - Stewart-Warner 10560C24, 10560G,	3-125	Pulsed Fuel Metering Valve - Stewart-Warner 10560M24B1, 10560G	3-88
Burner Replacement - Stewart-Warner 10560M, 10560M24B1	3-127	Radio Filter - Espar V7S	3-183
Burner Thermostat/Preheater Assembly Hupp 510B, 510C, MF60A-24V, MF60B-24V	3-58	Receptacle Connector - Hupp MF510B, MF510C, MF60A-24V, MF60B-24V	3-27
Circulating Pump - Espar V7S	3-174	Semiconductor Device - Stewart-Warner 10560C24, 10560G	3-120
Control Bracket Assembly - Hupp MF510B, MF510C, MF60A-24V, MF60B-24V	3-34	Solenoid Valve - Espar V7S	3-152
Diode Mounting Assembly - Stewart-Warner 10560M, 10560M24B1	3-122	Temperature Sensor - Espar V7S	3-140
Fixed Capacitor - Espar V7S	3-39	Terminal Board - Espar V7S	3-150
Fixed Wire Resistor - Espar V7S	3-146	Test Procedures	3-192
Flame Detector Switch Repair - Stewart-Warner 10560C24, 10560M, 10560G, 10560M24B1	3-72	Thermostatic Switch - Espar V7S	3-142
Fuel Regulator Valve - Stewart-Warner 10560C24, 10560M	3-74	Valve Relay - Hupp MF510B, MF510C, MF60A-24V, MF60B-24V	3-32
Fuel Regulator Valve - Hupp MF510B, MF510C, MF60A-24V, MF60B-24V	3-47	Voltage Regulator Assembly - Stewart-Warner 10560C24, 10560G	3-114
Fuel Lines and Fittings - Espar V7S	3-169	Voltage Regulator Assembly - Stewart-Warner 10560M, 10560M24B1	3-116
Fuel Pump - Espar V7S	3-176	Wiring Diagram - Espar V7S	3-25
Glow Plug - Espar V7S	3-138	Wiring Harness - Espar V7S	3-154
Heat Regulator - Espar V7S	3-179	Wiring Harness Repair - Espar V7S	3-161
Heater Thermostat - Hupp MF510B, MF510C, MF60A-24V, MF60B-24V	3-57		

RECEPTACLE CONNECTOR - HUPP MF510B, MF510C, MF60A-24V, MF50B-24V

This task covers:

- a. Removal
- b. Installation

INITIAL SETUP

Tools

Tool Kit, Mechanics Gen (Item 1, Appendix B)

Personnel Required

63G

Equipment Condition

Guard removed (page 2-32)

LOCATION	ITEM	ACTION	REMARKS
----------	------	--------	---------

REMOVAL

NOTE

Tag all wires and terminals to aid durhg installation (page 2-3)

1, Flame detector switch (1)	Two screw assemblies (2) and three leads (3)	Unscrew and remove.
------------------------------	--	---------------------

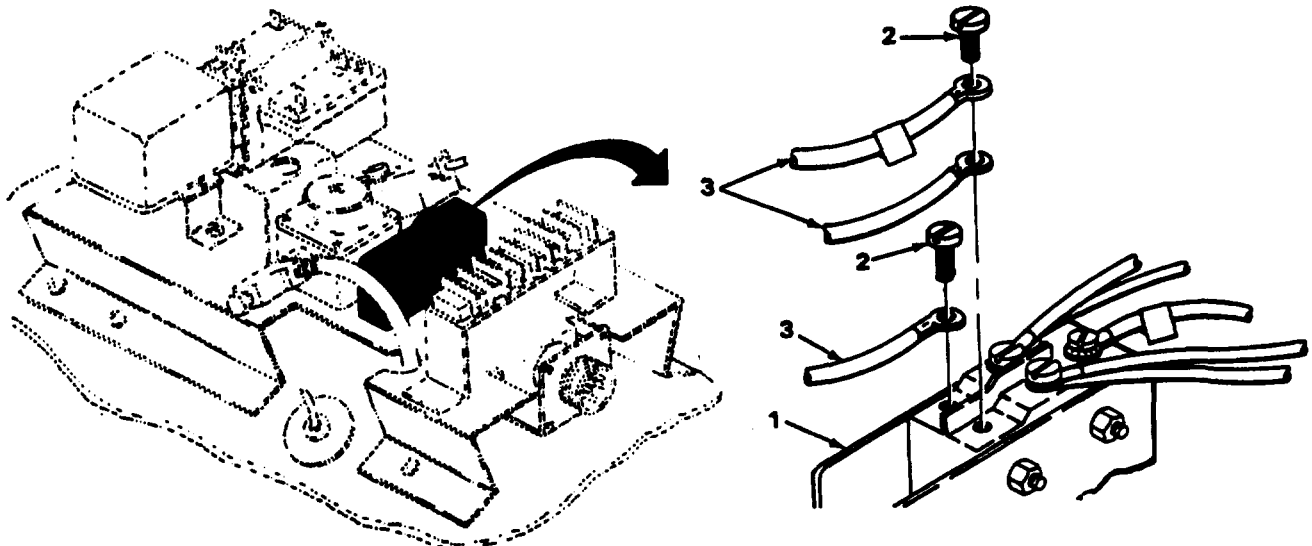

2. Control bracket assembly (1)	Screw assembly (2) and lead (3)	Unscrew and remove.
3. Terminal strip (4)	Two screw assemblies (5) and three leads (6)	Unscrew and remove.

RECEPTACLE CONNECTOR - HUPP MF510B, MF510C, MF60A-24V, MF60B-24V - Continued

LOCATION	ITEM	ACTION REMARKS
REMOVAL - Continued		
4. Control bracket assembly (1) and receptacle connector (7)	Four screw assemblies (8)	Unscrew and remove.
5. Control bracket assembly (1)	Receptacle connector (7)	Unscrew and remove.
INSTALLATION		
6. Control bracket assembly (1)	Receptacle connector (7)	a. Feed wire leads under terminal strip (9). b. Install from behind mounting lip of control bracket assembly (1),
7. Control bracket assembly (1) and receptacle connector (7)	Four screw assemblies (8)	Screw in and tighten,
8. Terminal strip (4)	Three leads (6) and two screw assemblies (5)	a. Install, noting tags made during removal. b. Screw in and tighten.
9. Control bracket assembly (1)	Lead (3) and screw assembly (2)	a. Place proper lead in position noting tags made during removal. b. Screw in and tighten.
10. Flame detector switch (9)	Three leads (10) and two screw assemblies (11)	a. Install, noting tags made during removal. b. Screw in and tighten.

RECEPTACLE CONNECTOR - HUPP MF510B, MF510C, MF60A-24V, MF60B-24V - Continued

LOCATION	ITEM	ACTION	REMARKS
----------	------	--------	---------

INSTALLATION - Continued

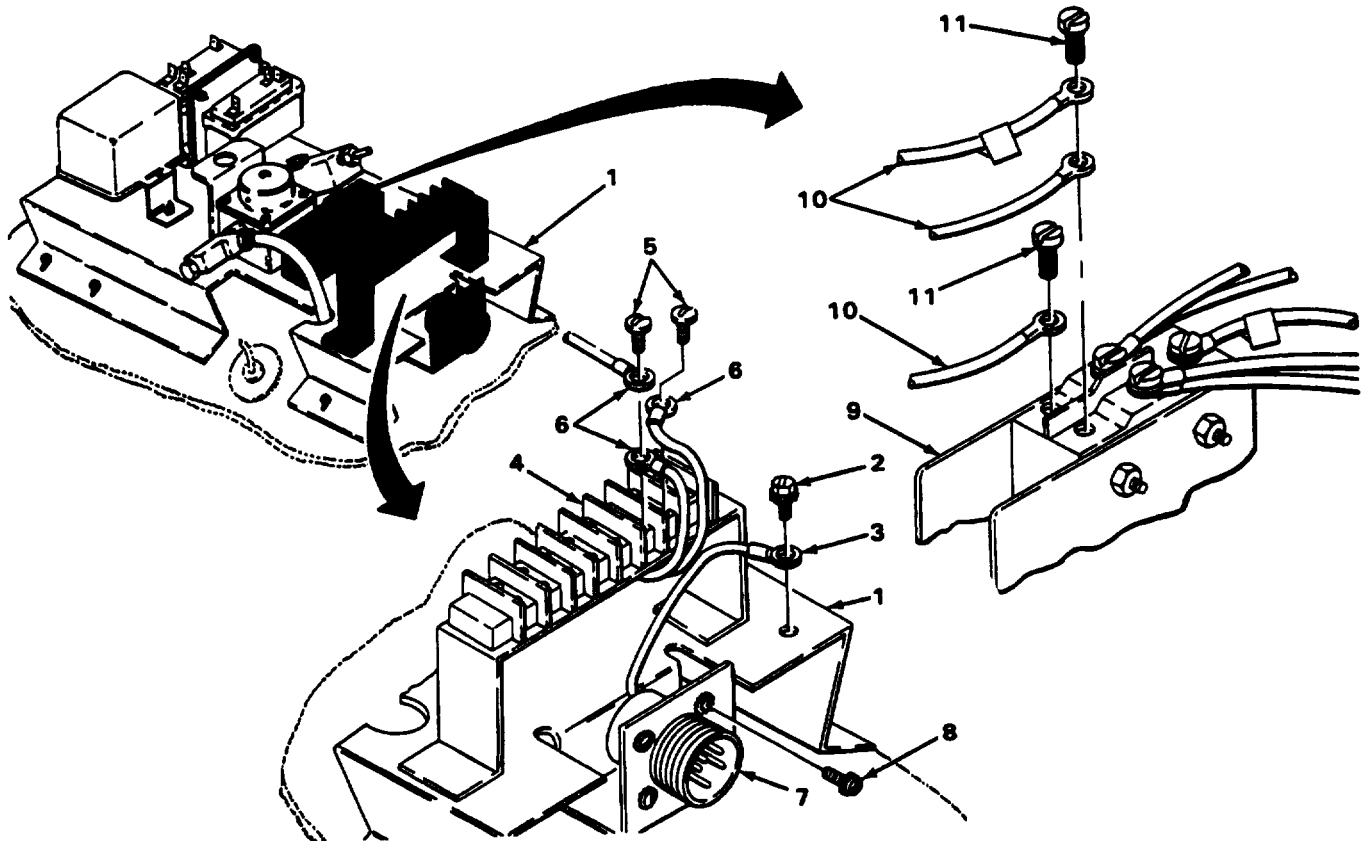

NOTE

FOLLOW-ON MAINTENANCE: Install guard (page 2-32)

TASK ENDS HERE

HI/LO FIRE RELAY - HUPP MF510B, MF510C, MF60A-24V, MF60B-24V

This task covers:

- a. Removal
 - b. Installation
-

INITIAL SETUP

Tools	Personnel Required
Tool Kit, Mechanics Gen (Item 1, Appendix B)	63G
Materials/Parts	Equipment Condition
Tags, marking, (Item 9, Appendix C)	Guard removed (page 2-32)

LOCATION	ITEM	ACTION REMARKS
----------	------	-------------------

REMOVAL

NOTE

Tag all wires and terminals to aid during installation (page 2-3).

1. Terminal strip (1)	Screw assembly (2) and lead (3)	Unscrew and remove.
2. Flame detector switch (4)	Two screw assemblies (5) and four leads (6)	Unscrew and remove.
3. Hi/LO fire relay (7) and control bracket assembly (8)	Two screw assemblies (9) and nut assemblies (10)	Unscrew and remove.
4. Control bracket assembly (8)	Hi/LO fire relay (7)	Remove,

INSTALLATION

5. Control bracket assembly (8)	Hi/LO fire relay (7)	Install.
6. Hi/LO fire relay (7) and control bracket assembly (8)	Two screw assemblies (6) and nut assemblies (10)	Screw in and tighten.
7. Terminal strip (1)	Lead (3) and screw assemblies (2)	a. Install, noting tags made during removal. b. Screw in and tighten.
8. Flame detector switch (4)	Four leads (6) and two screw assemblies (5)	a. Install, noting tags made during removal. b. Screw in and tighten.

HI/LO FIRE RELAY- HUPP MF510B, MF510C, MF60A-24V, MF60B-24V - Continued

LOCATION	ITEM	ACTION	REMARKS
----------	------	--------	---------

INSTALLATION - Continued

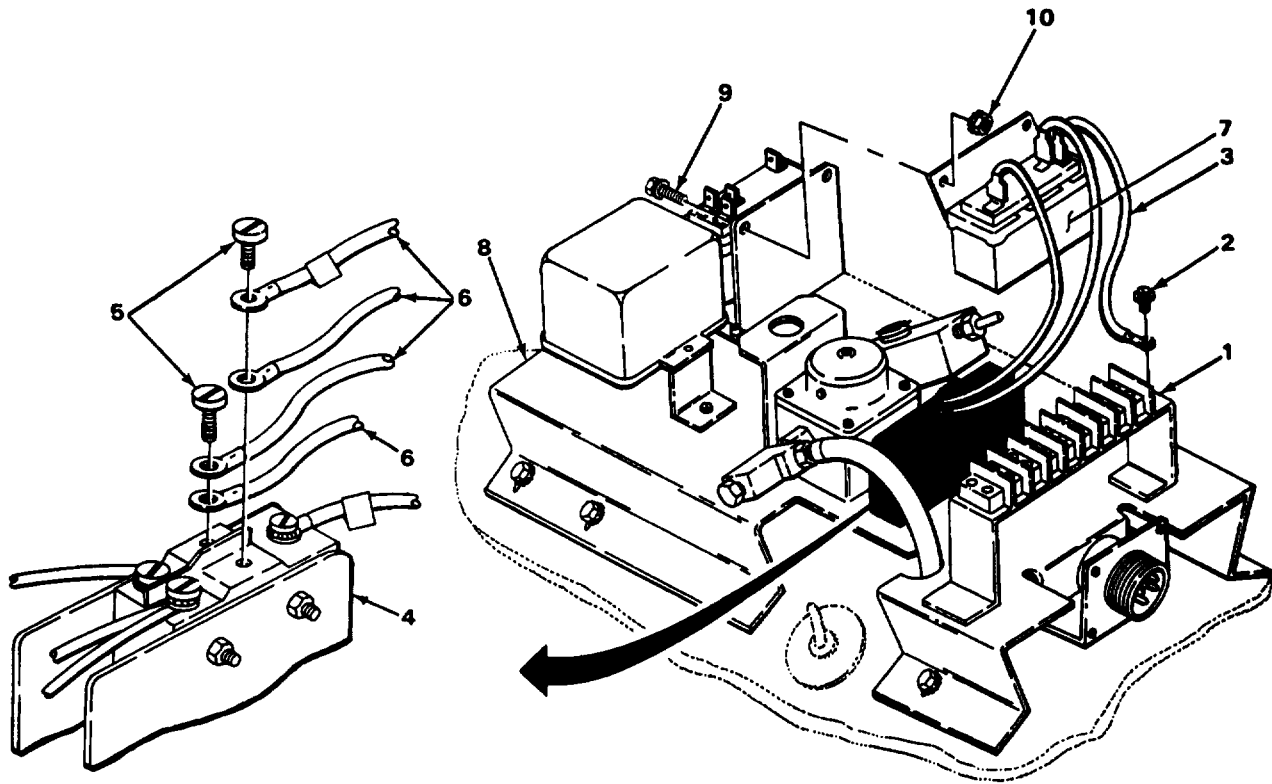

NOTE

FOLLOW-ON MAINTENANCE: install guard (page 2-32)

TASK ENDS HERE

VALVE RELAY - HUPP MF510B, MF510C, MF60A-24V, MF60B-24V

This task covers:

- a. Removal
 - b. Installation
-

INITIAL SETUP

Tools	Personnel Required
Tool Kit, Mechanics Gen (Item 1, Appendix B)	63G
Materials/Parts	Equipment Condition
Tags, marking, (Item 9, Appendix C)	Guard removed (page 2-32)

LOCATION	ITEM	ACTION REMARKS
----------	------	-------------------

REMOVAL

NOTE

Tag all wires and terminals to aid during installation (page 2-3).

1. Terminal strip (1)	Three screw assemblies (2) and leads (3)	Unscrew and remove.
2. Control bracket assembly (4) and valve relay (5)	Two screw assemblies (6) and nut assemblies (7)	Unscrew and remove.
3. Control bracket assembly (4)	Valve relay (5)	Remove.
 INSTALLATION		
4. Control bracket assembly (4)	Valve relay (5)	Install.
5. Valve relay (5) and control bracket assembly (4)	Two screw assemblies (6) and nut assemblies (7)	Screw in and tighten.
6. Terminal strip (1)	Three leads (3) and screw assemblies (2)	a. Install, noting tags made during removal. b. Screw in and tighten.

VALVE RELAY - HUPP MF510B, MF510C, MF60A-24V, MF60B-24V - Continued

LOCATION	ITEM	ACTION	REMARKS
----------	------	--------	---------

INSTALLATION - Continued

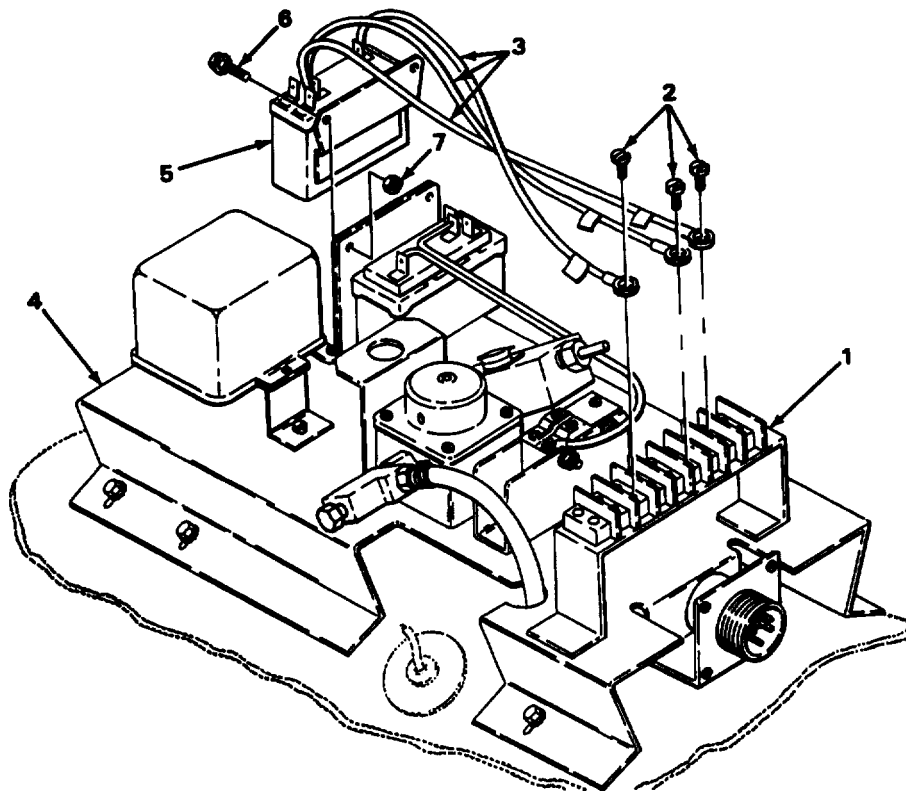

NOTE

FOLLOW-ON MAINTENANCE: Install guard (page 2-32)

TASK ENDS HERE

CONTROL BRACKET ASSEMBLY - HUPP MF510B, MF510C, MF60A-24V, MF60B-24V

This task covers:

- | | |
|--|---|
| <ul style="list-style-type: none"> a. Removal b. Replacement | <ul style="list-style-type: none"> c. Installation |
|--|---|

INITIAL SETUP

Tools	Personnel Required
Tool Kit, Mechanics Gen (Item 1, Appendix B)	63G
Materials/Parts	Equipment Condition
Tags, marking, (Item 9, Appendix C)	Guard removed (page 2-32)

LOCATION	ITEM	ACTION
		REMARKS

REMOVAL

NOTE

Tag all wires and terminals to aid during installation (page 2-3)

1. Heater (1)	Igniter cover (2)	Remove.
2. Igniter (3)	Nut assembly (4) and lead (5)	<ul style="list-style-type: none"> a. Unscrew and remove. b. Pull grommet (6) out of igniter cover (2). c. Take igniter cover (2) from lead (5),
3. Fuel hose (7)	Hose clamp (8)	Unscrew part way.
4. Fuel tube (9)	Fuel hose (7)	Remove.
5. Terminal strip (10)	Five screw assemblies (11) and nine leads (12)	Unscrew and remove.
6. Control bracket assembly (13)	Six screws (14)	Unscrew and remove.
7. Heater (1)	Control bracket assembly (13)	<ul style="list-style-type: none"> a. Lift up. b. Pull eight leads through grommet (15) one at a time,

CONTROL BRACKET ASSEMBLY-HUPP MF510B, MF510C, MF60A-24V, MF60B-24V - Continued

LOCATION	ITEM	ACTION	REMARKS
----------	------	--------	---------

REMOVAL - Continued

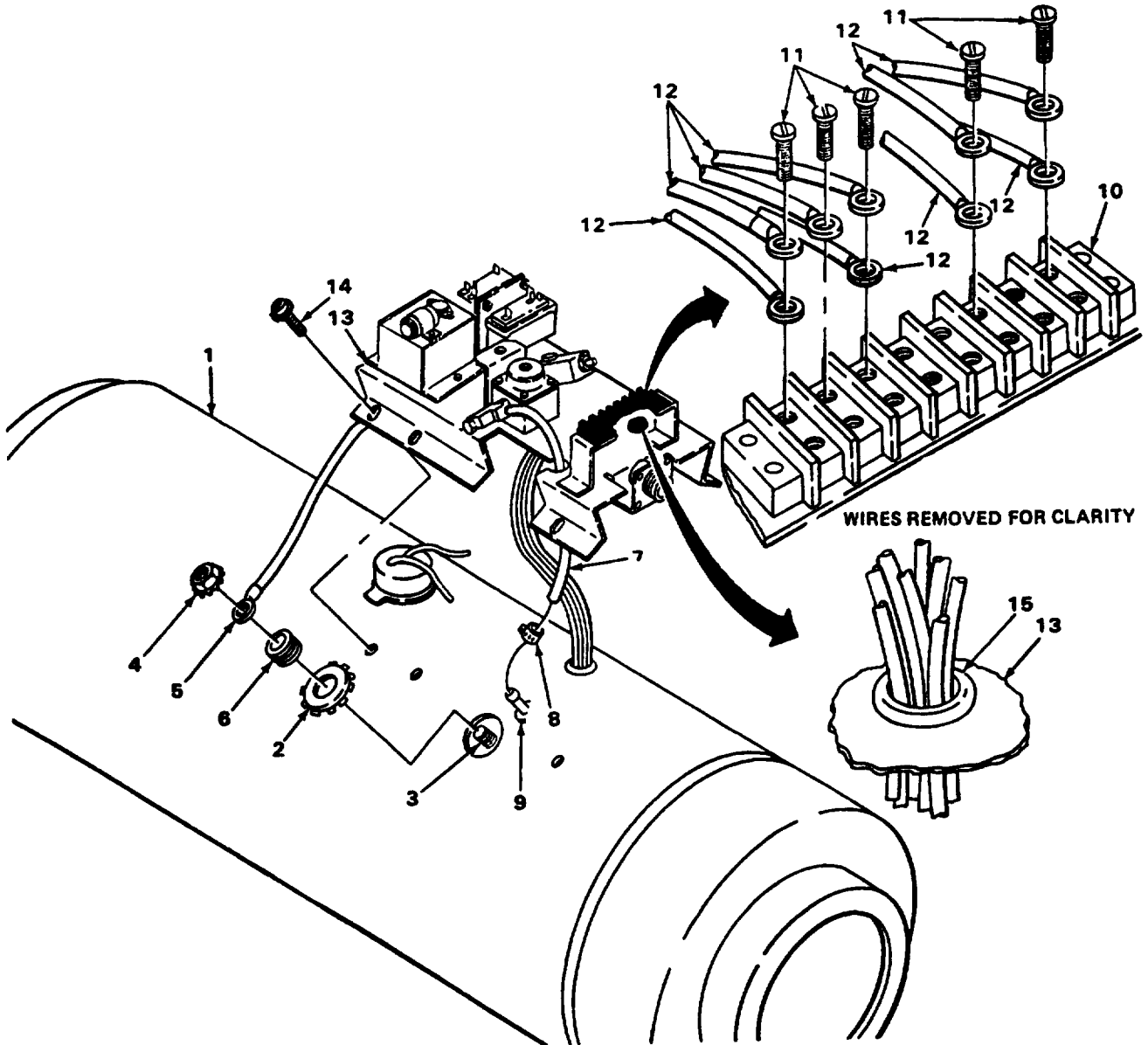

CONTROL BRACKET ASSEMBLY - HUPP MF510B, MF510C, MF60A-24V, MF60B-24V - Continued

LOCATION	ITEM	ACTION	REMARKS
----------	------	--------	---------

REPLACEMENT

NOTE

Only do steps 8 thru 23 if control bracket assembly is damaged and needs to be replaced.

8. Control bracket assembly (1)	Igniter relay/power control	Remove (page 3-41, 3-43),
9.	HI/LO fire relay	Remove (page 3-30).
10.	Valve relay	Remove (page 3-32).
11.	Electrical connector	Remove (page 3-69).
12.	Fuel regulator valve	Remove (page 3-47).
13. Terminal strip (2)	Two screw assemblies (3)	Unscrew and remove.
14. Control bracket assembly (1)	Terminal strip (2)	Remove.
15.	Grommet (4)	Remove.
16.	Grommet (4)	Install.
17.	Terminal strip (2)	install.
18. Terminal strip (2)	Two screw assemblies (3)	Screw in and tighten.
19. Control bracket assembly (1)	Fuel regulator valve	Install (page 3-47).
20.	Electrical connector	Install (page 3-69).
21.	Valve relay	Install (page 3-32).
22.	HI/LO fire relay	Install (page 3-30).
23.	Igniter relay/power control	Install (page 3-41, 43)

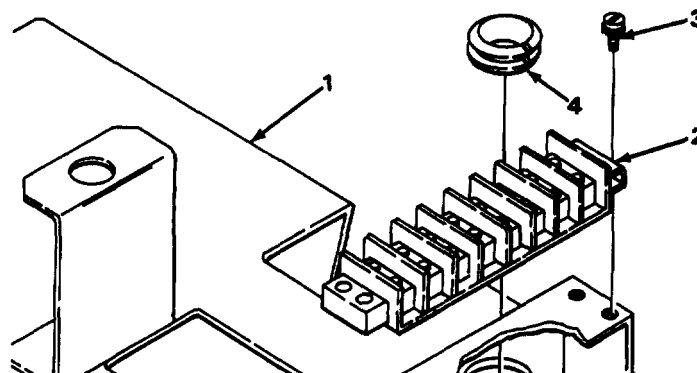

CONTROL BRACKET ASSEMBLY - HUPP MF510B, MF510C, MF60A-24V, MF60B-24V - Continued

LOCATION	ITEM	ACTION REMARKS
INSTALLATION		
24. Grommet (1)	Eight leads (2)	Feed through grommet (1), one at a time.
25. Heater (3)	Control assembly bracket (4)	Install.
26. Fuel tube (5)	Fuel hose (6)	Install.
27. Fuel hose (6)	Hose clamp (7)	Tighten.
28. Control bracket assembly (4)	Six screw assemblies (8)	Screw in and tighten.
29. Igniter (9)	Lead (10) and nut assembly (11)	a. Feed lead (10) through igniter cover (12). b. Feed lead (10) through grommet (13), and push into igniter cover (12). c. Place lead (10) on igniter (9). d. Screw on and tighten.
30. Heater (3)	Igniter cover (12)	Install.
31. Terminal strip (14)	Nine leads (15) and five screw assemblies (16)	a. Install, noting tage made during removal. b. Screw in and tighten.

CONTROL BRACKET ASSEMBLY - HUPP MF510B, MF510C, MF60A-24V, MF60B-24V - Continued

LOCATION	ITEM	ACTION	REMARKS
----------	------	--------	---------

INSTALLATION - Continued

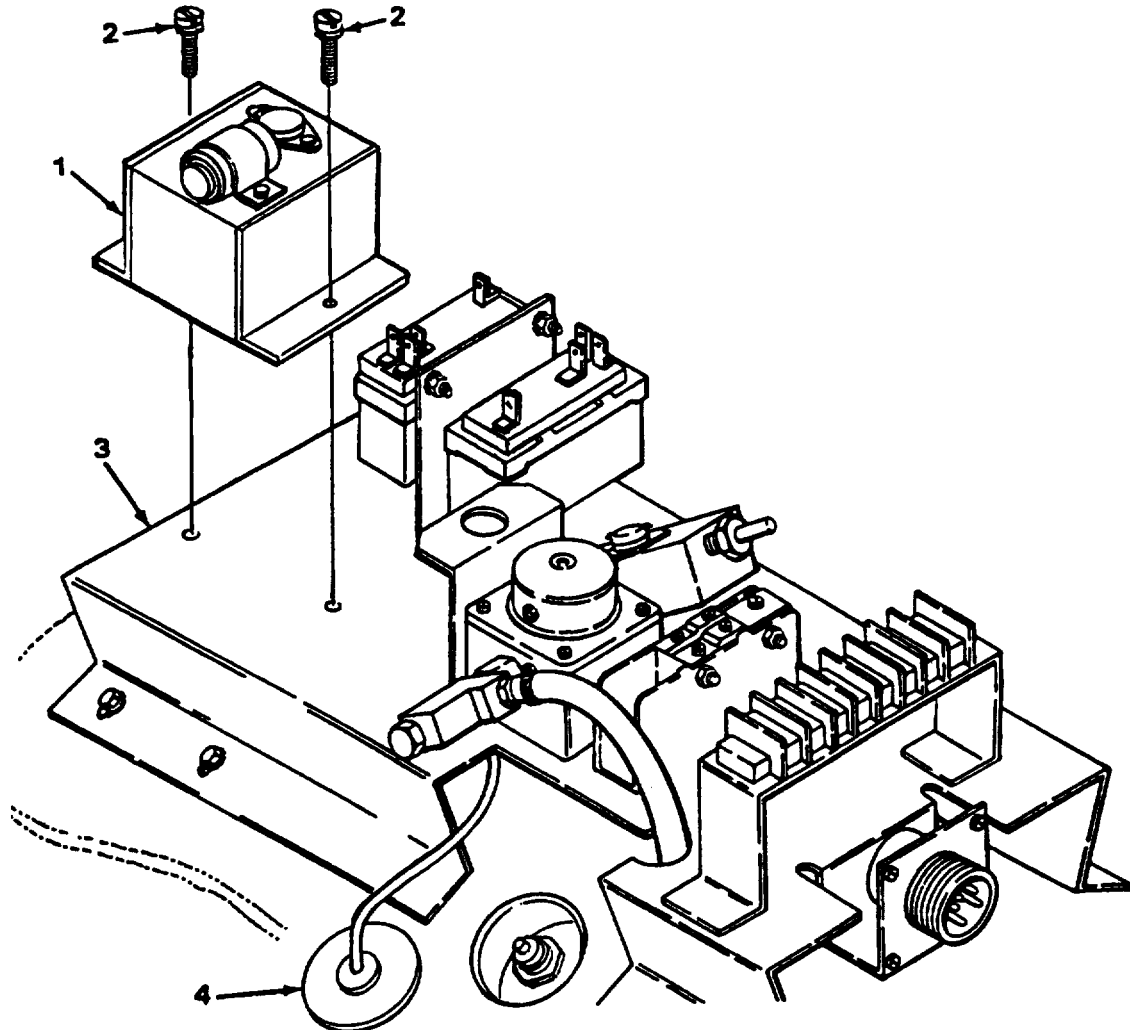

NOTE
 FOLLOW-ON MAINTENANCE: Install flame detector switch (page 2-33)

TASK ENDS HERE

CAPACITOR - HUPP MF60A-24V, MF60B-24V

This task covers:

- a. Removal
 - b. Installation
-

INITIAL SETUP

Tools	Personnel Required
Tool Kit, Mechanics Gen (Item 1, Appendix B)	63G
Materials/Parts	Equipment Condition
Hose (Item 9, Page D-17)	Guard removed (page 2-32)

LOCATION	ITEM	ACTION REMARKS
----------	------	-------------------

REMOVAL

1. Fuel hose (1)	Clamp (2)	Loosen clamp and remove fuel line.
2. Lead 8 (3)	Screw (4)	Remove screw from terminal 8.
3. Capacitor (5)	Screw (6)	Remove.
4. Capacitor (5)	Clamp (7)	Remove.

INSTALLATION

5. Capacitor (5)	Clamp (7)	Slip clamp over capacitor and install.
6. Capacitor (5)	Screw (6)	Screw in and tighten.
7. Lead 8 (3)	Screw (4)	Install and tighten.
8. Fuel hose (1)	Clamp (2)	Connect fuel hose and install clamp.

CAPACITOR - HUPP MF60A-24V, MF60B-24V - Continued

LOCATION	ITEM	ACTION	REMARKS
----------	------	--------	---------

INSTALLATION - Continued

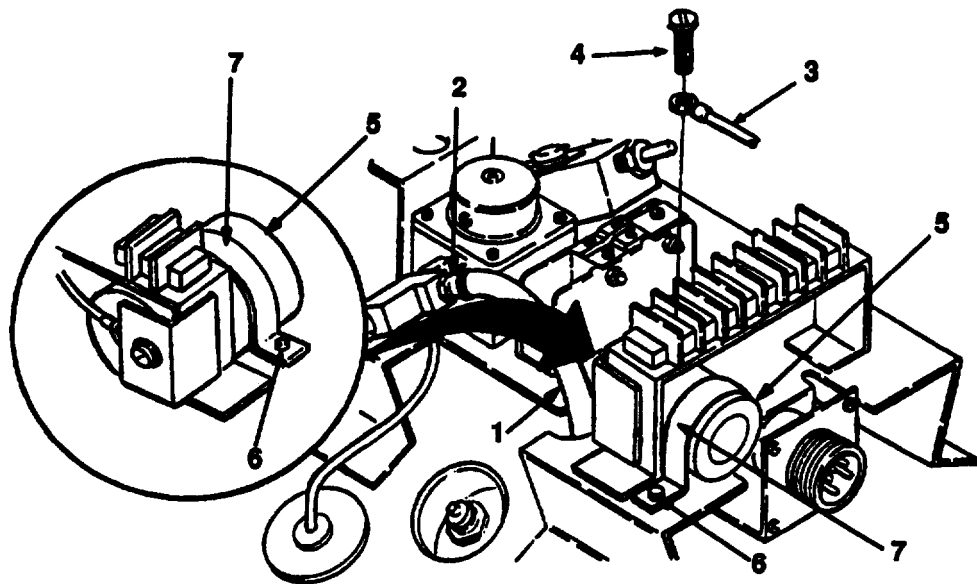

NOTE

FOLLOW-ON MAINTENANCE: Install guard (page 2-32)

TASK ENDS HERE

IGNITOR RELAY - HUPP MF510B

This task covers:

- a. Removal
 - b. Installation
-

INITIAL SETUP

Tools	Personnel Required
Tool Kit, Mechanics Gen (Item 1, Appendix B)	63G
Materials/Parts	Equipment Condition
Tags, marking, (Item 9, Appendix C)	Guard removed (page 2-32)

LOCATION	ITEM	ACTION REMARKS
----------	------	-------------------

REMOVAL

NOTE

Tag all wires and terminals to aid during installation (page 2-3).

1. Igniter relay/voltage regulator (1)	Two screw assemblies (2)	Unscrew and remove.
2. Control bracket assembly (3)	Igniter relay/voltage regulator (1)	Remove.
3. Igniter relay/voltage regulator (1)	Two screw assemblies (4), nut assemblies (5), and leads (6)	Remove.

INSTALLATION

4. Igniter relay/voltage regulator (1)	Two leads (6), screw (4), and nut assemblies (5)	Install, noting tags made during removal.
5. Control, bracket assembly (3)	Igniter relay/voltage regulator (1)	Install.
6. Igniter relay/voltage regulator (1)	Two screws (2)	Screw in and tighten.

IGNITOR RELAY - HUPP MF510B - Continued

LOCATION	ITEM	ACTION	REMARKS
----------	------	--------	---------

INSTALLATION - Continued

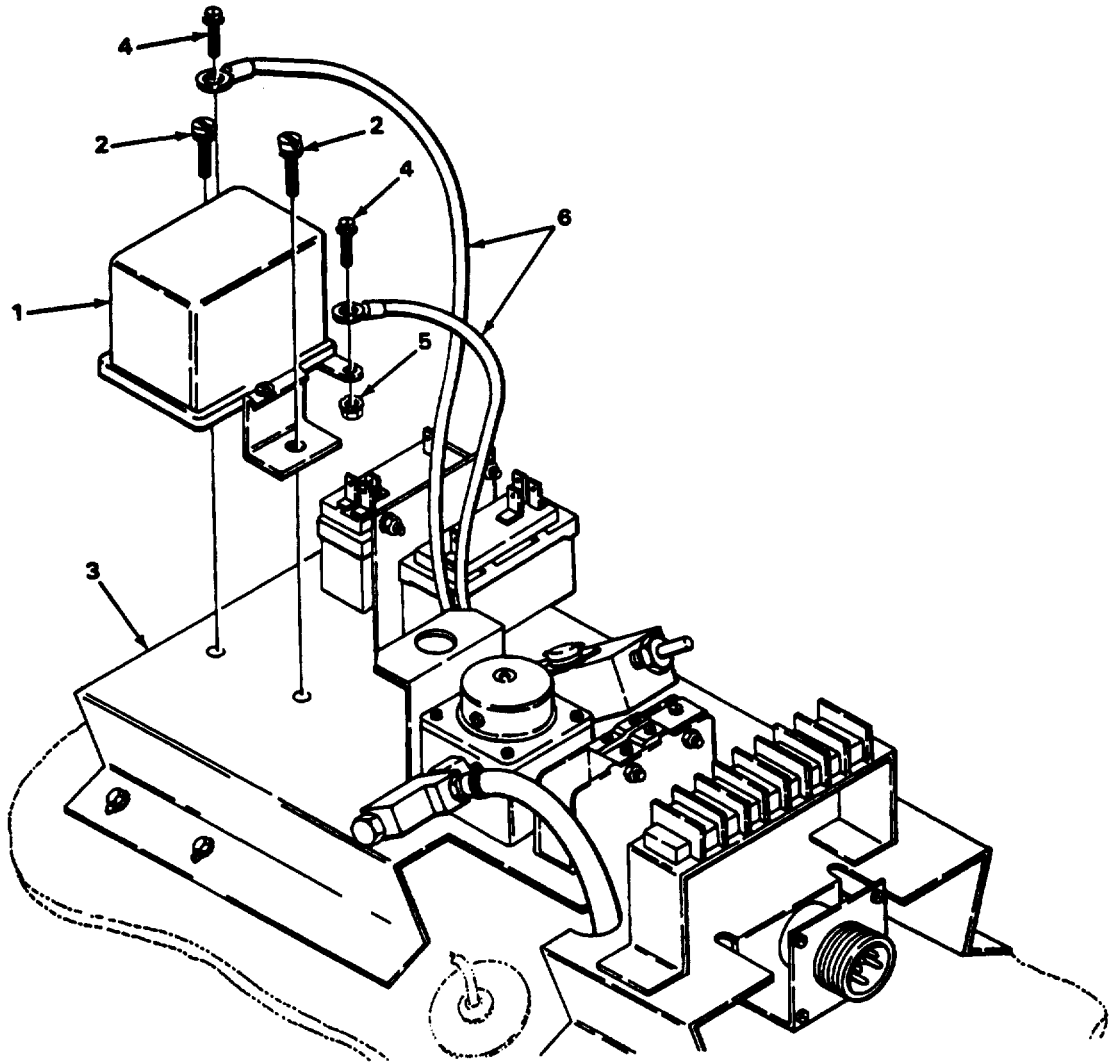

NOTE

FOLLOW-ON MAINTENANCE: Install guard (page 2-32)

TASK ENDS HERE

POWER CONTROL - HUPP MF510C, MF60A-24V, MF60B-24V

This task covers:

- | | | |
|----------------|-----------------|---------|
| a. Removal | c. Assembly | e. Test |
| b. Disassembly | d. Installation | |

INITIAL SETUP

<p>Tools</p> <p>Tool Kit, Mechanics Gen (Item 1, Appendix B) Solder gun 9 (Item 4, Appendix B)</p>	<p>Personnel Required</p> <p>63G</p>
<p>Materials/Parts</p> <p>Insulating Compound (Item 3, Appendix C) Transistor Solder (Item 7, Appendix C) Flux (Item 3, Appendix C)</p>	<p>Equipment Condition</p> <p>Guard removed (page 2-32)</p>

LOCATION	ITEM	ACTION	REMARKS
----------	------	--------	---------

REMOVAL

NOTE

Tag all wires and terminals to aid during installation (page 2-3).

- | | | |
|-----------------------|---|---------------------|
| 1. Power control (1) | Two screw assemblies (2) | Unscrew and remove. |
| 2. Igniter (3) | Igniter cover (4) | Remove. |
| 3. Igniter (3) | Nut assembly (5) and wire (6),
and grommet (7) | Remove. |
| 4. Terminal strip (8) | Screw assembly (9) and wire (10) | Remove. |

DISASSEMBLY

- | | | |
|----------------------|---|----------------------------|
| 5. Circuit board(11) | Four screws (15) and four
nuts (16) | Remove. |
| 6. Transistor (17) | Two screws (18), three nuts (19),
three washers (12), and one wire
(20) | Unsolder wires and remove. |
| 7. Power control (1) | Transistor (17) | Remove. |

POWER CONTROL - HUPP MF510C, MF60A-24V, MF60B-24V - Continued

LOCATION	ITEM	ACTION	REMARKS
----------	------	--------	---------

DISASSEMBLY - Continued

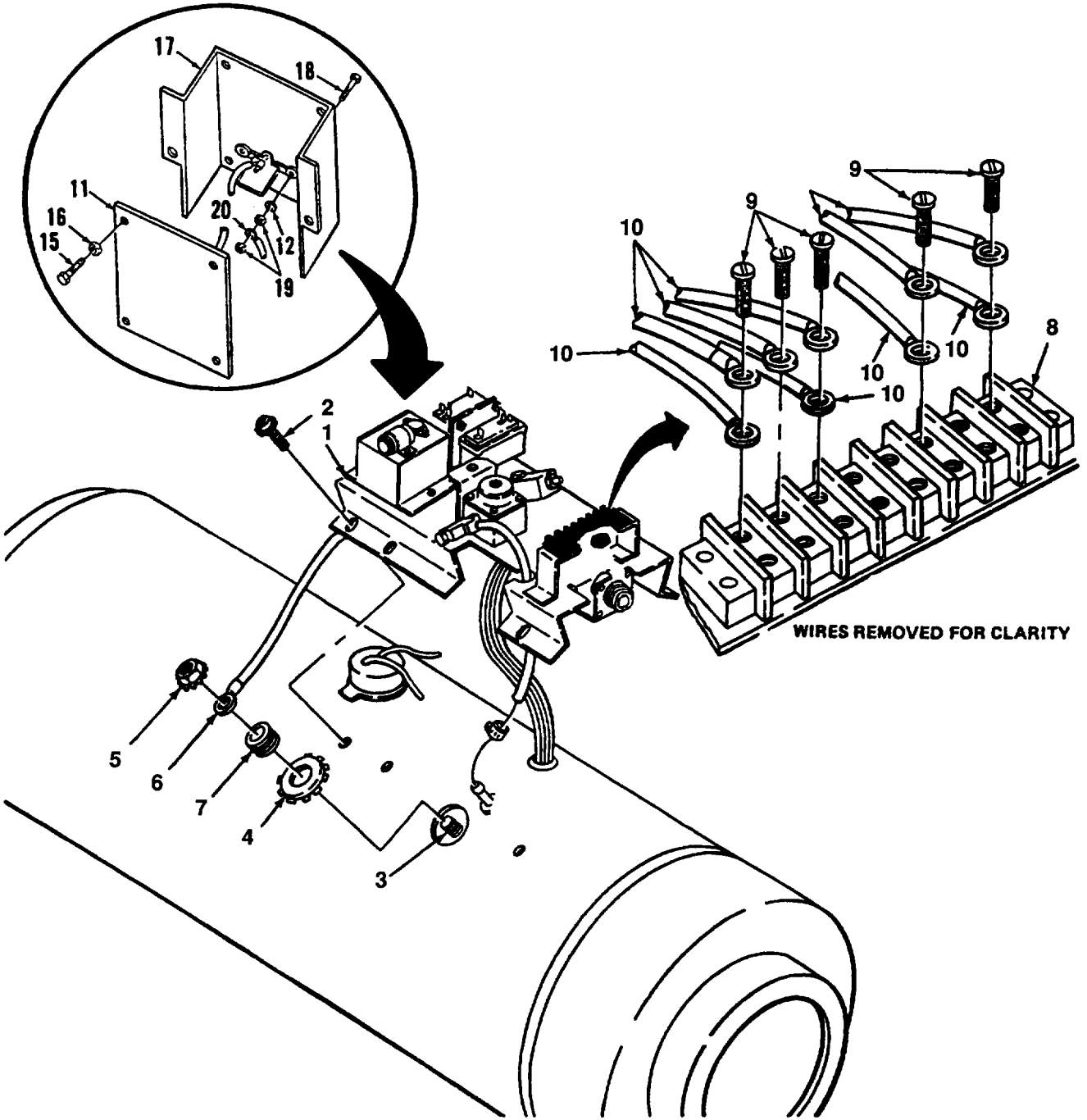

POWER CONTROL - HUPP MF510C, MF60A-24V, MF60B-24V - Continued

LOCATION	ITEM	ACTION REMARKS
ASSEMBLY		
8. Transistor (17)	Two screws (18), three nuts (19), three washers (12), and one wire (15)	Install.
9. Transistor (17)	Wire (15)	Solder wire to transistor.
10. Circuit board (11)	Four screws (15), and four nuts (16)	Screw in and tighten.
INSTALLATION		
11. Terminal strip (6)	Screw assembly (9) and wire (10)	Install wire and tighten.
12. Igniter (3)	One nut assembly (5), one wire (6) and grommet (7)	Tighten.
13. Igniter (3)	Igniter cover (4)	Install.
14. Power control (1)	Two screw assemblies (2)	Install wire and tighten.
TEST		
15. Transistor (17)	Test	See (page 3-1 92).

POWER CONTROL - HUPP MF510C, MF60A-24V, MF60B-24V - Continued

LOCATION	ITEM	ACTION	REMARKS
----------	------	--------	---------

TEST - Continued

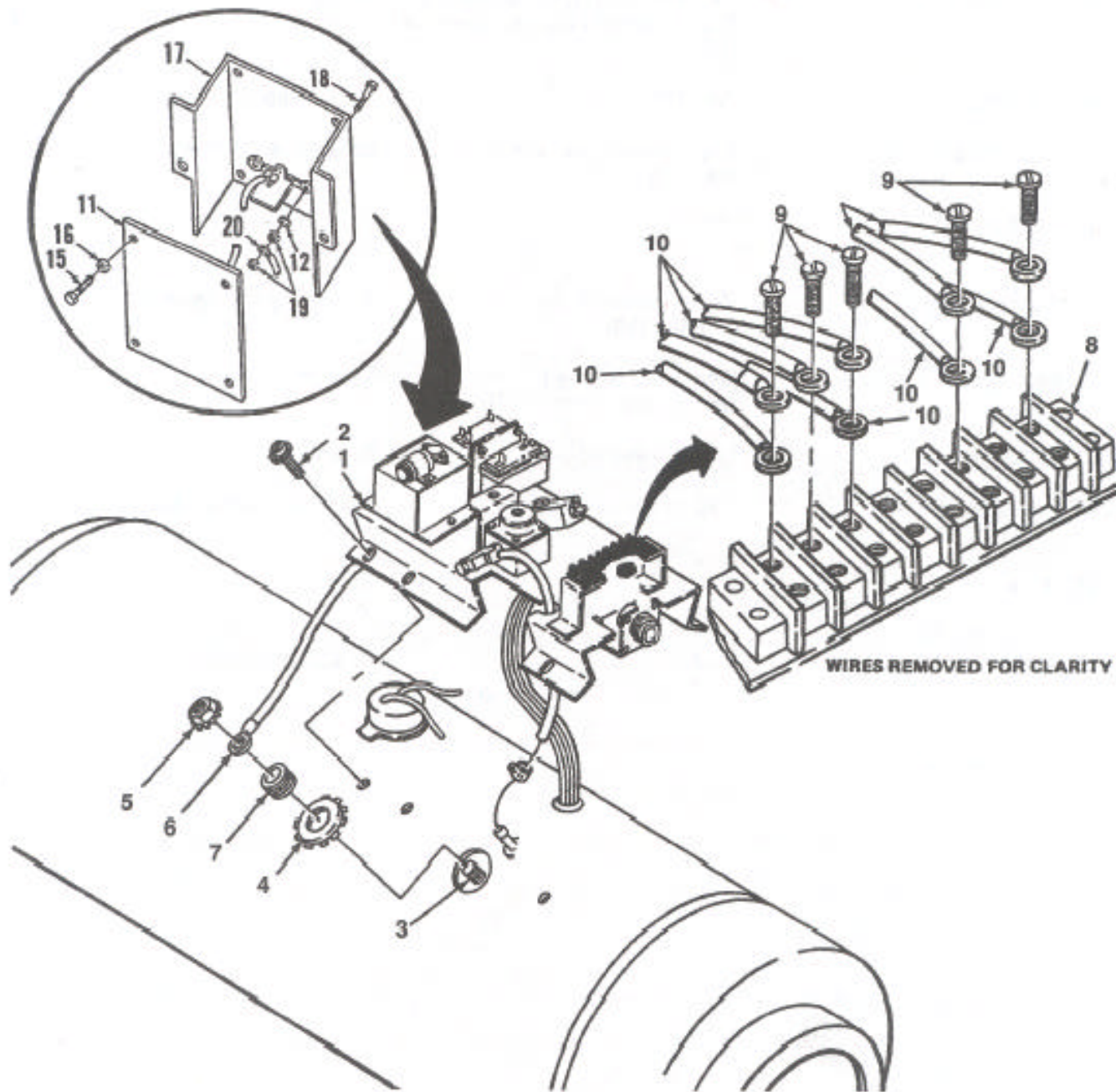

NOTE

FOLLOW-ON MAINTENANCE: Install guard (page 2-32)

FUEL REGULATOR VALVE - HUPP MF510B, MF510C, MF60A-24V, MF60B-24V

This task covers:

- | | | |
|----------------|-----------------|---------------|
| a. Removal | c. Assembly | e. Adjustment |
| b. Disassembly | d. Installation | |
-

INITIAL SETUP

Tools	Personnel Required
Tool Kit, Mechanics Gen (Item 1, Appendix B)	63G
Materials/Parts	Equipment Condition
Cylinder, graduated, 100 cc capacity Pan, drain Sealant, silicon (Item 6, Appendix C)) Tags, marking (item 9, Appendix C)	Guard removed (page 2-32)

LOCATION	ITEM	ACTION REMARKS
----------	------	-------------------

REMOVAL

NOTE

Tag all wires and terminals to aid during installation (page 2-3).

1. Terminal strip (1)	Five screws (2) and nine leads (3)	Unscrew and remove thermal valve lead from terminal 3, regulator valve lead from terminal 4, all leads from terminal 5, and regulator valve lead from terminal 7.
2. Fuel hose (4)	Hose clamp (5)	Unscrew part way.
3. Fuel tube (6)	Fuel hose (4)	Remove.
4. Control bracket assembly (7)	Two screw assemblies (8)	Unscrew and remove.
5.	Fuel regulator valve (9)	Remove.

FUEL REGULATOR VALVE - HUPP MF510B, MF510C, MF60A-24V, MF60B-24V - Continued

LOCATION	ITEM	ACTION	REMARKS
----------	------	--------	---------

REMOVAL - Continued

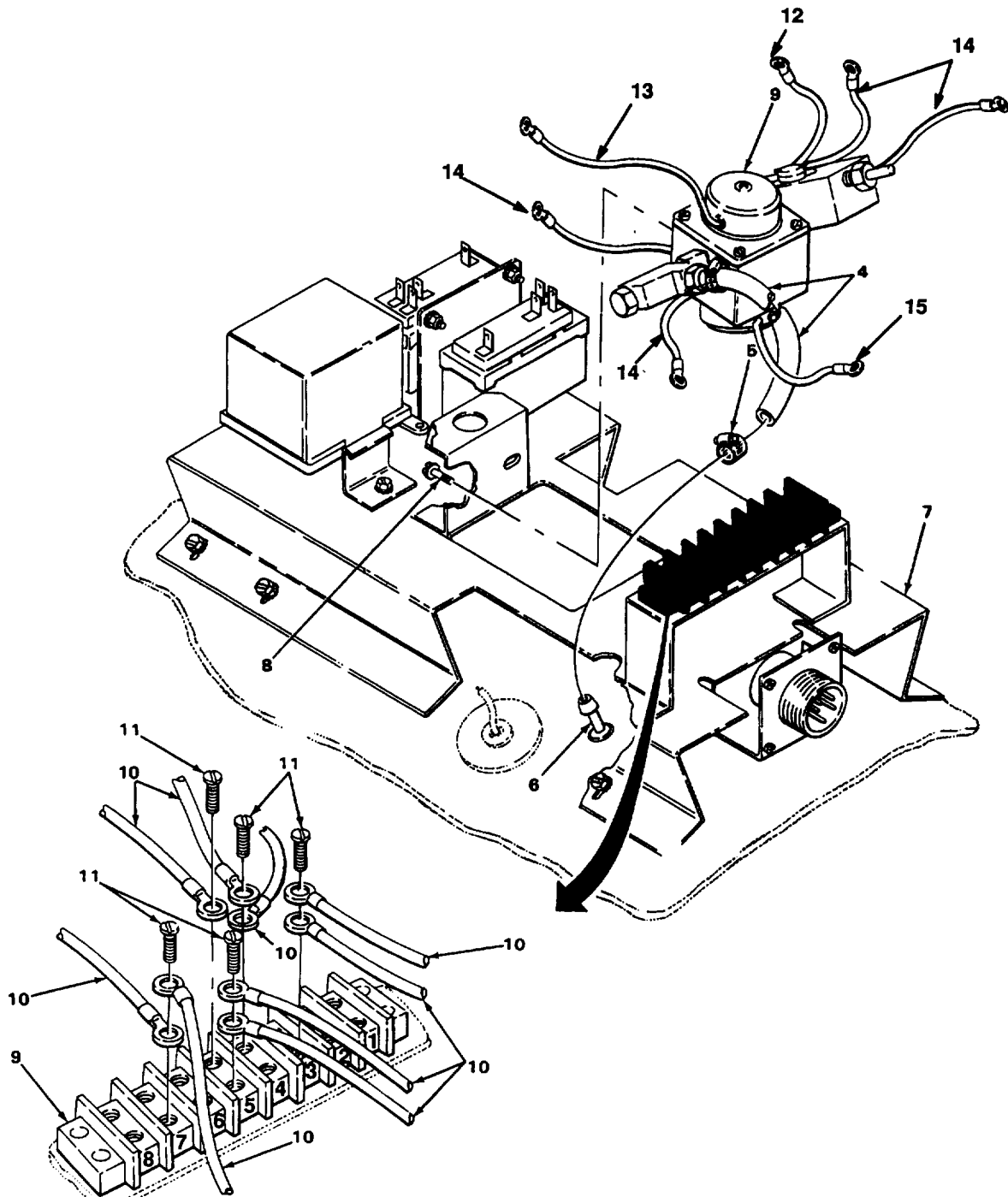

FUEL REGULATOR VALVE - HUPP MF510B, MF510C, MF60A-24V, MF50B-24V - Continued

LOCATION	ITEM	ACTION REMARKS
DISASSEMBLY		
6. Fuel hose (1)	Clamp (2)	Unscrew part way.
7. Fuel line adapter (3)	Fuel hose (1)	Remove.
8. Tee (4)	Fuel line adapter (3)	Unscrew and remove.
9.	Plug (5)	Unscrew and remove.
10.	Nozzle (6)	Unscrew and remove.
11. Adapter (7)	Tee (4)	Unscrew and remove.
12. Regulator valve (8)	Adapter (7)	Unscrew and remove.
13. Reservoir (9)	Valve thermostat	Remove (page 2-37).
14. Nipple (10)	Reservoir (9)	Unscrew and remove.
15. Regulator valve (8)	Nipple (10)	a. Place valve (8) in vise equipped with jaw caps. b. Unscrew and remove.
16. Regulator valve (8) and two element assemblies (11)	Four nuts (12)	Remove.
17. Regulator valve (8)	Two element assemblies (11)	Remove.
ASSEMBLY		
18. Regulator valve (8)	Two element assemblies (11)	a. Install two nuts (12) on element assemblies (11). b. Feed element assemblies (11) through regulator valve (8). c. Install other two nuts (12) on element assemblies (11) to secure in valve (8).
19.	Nipple (10)	a. Screw in and tighten. b. Take valve (8) out of vise.
20. Nipple (10)	Reservoir (9)	Screw on and tighten.
21. Reservoir (9)	Valve thermostat	Install (page 2-32).
22. Regulator valve (8)	Adapter (7)	Screw in and tighten.

FUEL REGULATOR VALVE - HUPP MF510B, MF510C, MF60A-24V, MF60B-24V - Continued

LOCATION	ITEM	ACTION	REMARKS
----------	------	--------	---------

ASSEMBLY - Continued

23. Adapter (7)	Tee (4)	Screw on and tighten.	
24. Tee (4)	Nozzle (6)	Screw in part way.	
25.	Plug (5)	Screw in and tighten.	
26.	Fuel line adapter (3)	Screw in and tighten.	
27. Fuel line adapter (1)	Fuel hose (2)	Install.	
28. Fuel hose (2)	Clamp (3)	a. Position clamp (3) on hose (2) so it is over adapter (1). b. Tighten.	

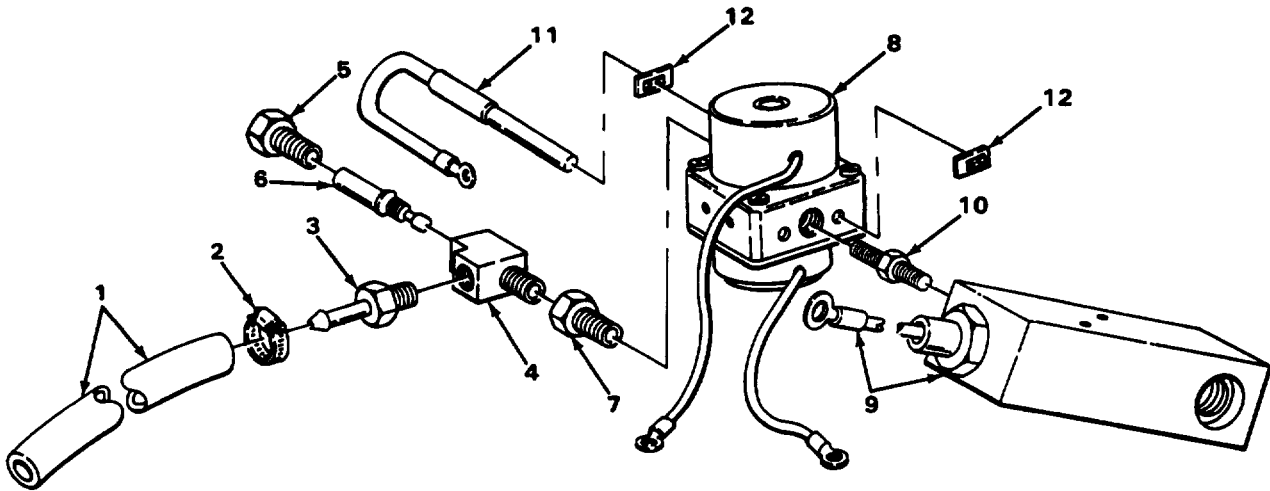

FUEL REGULATOR VALVE - HUPP MF510B, MF510C, MF60A-24V, MF60B-24V - Continued

LOCATION	ITEM	ACTION REMARKS
----------	------	-------------------

INSTALLATION

29.	Control bracket assembly (4) Fuel regulator valve (5)	Install.
30.	Two screw assemblies (6)	Screw in and tighten.

NOTE

If fuel regulator valve adjustment is required, omit steps 31 and 32.

31.	Fuel tube (7) Fuel hose (2)	install.
32.	Fuel hose (2) Clamp (8)	a. Position clamp (8) on hose (2) so it is over fuel tube (7). b. Tighten.
33.	Terminal strip (9) Nine leads (1 O) and five screw assemblies (11)	a. install, noting tags made during removal. b. Screw in and tighten.

FUEL REGULATOR VALVE - HUPP MF510B, MF510C, MF60A-24V, MF60B-24V - Continued

LOCATION	ITEM	ACTION	REMARKS
----------	------	--------	---------

INSTALLATION - Continued

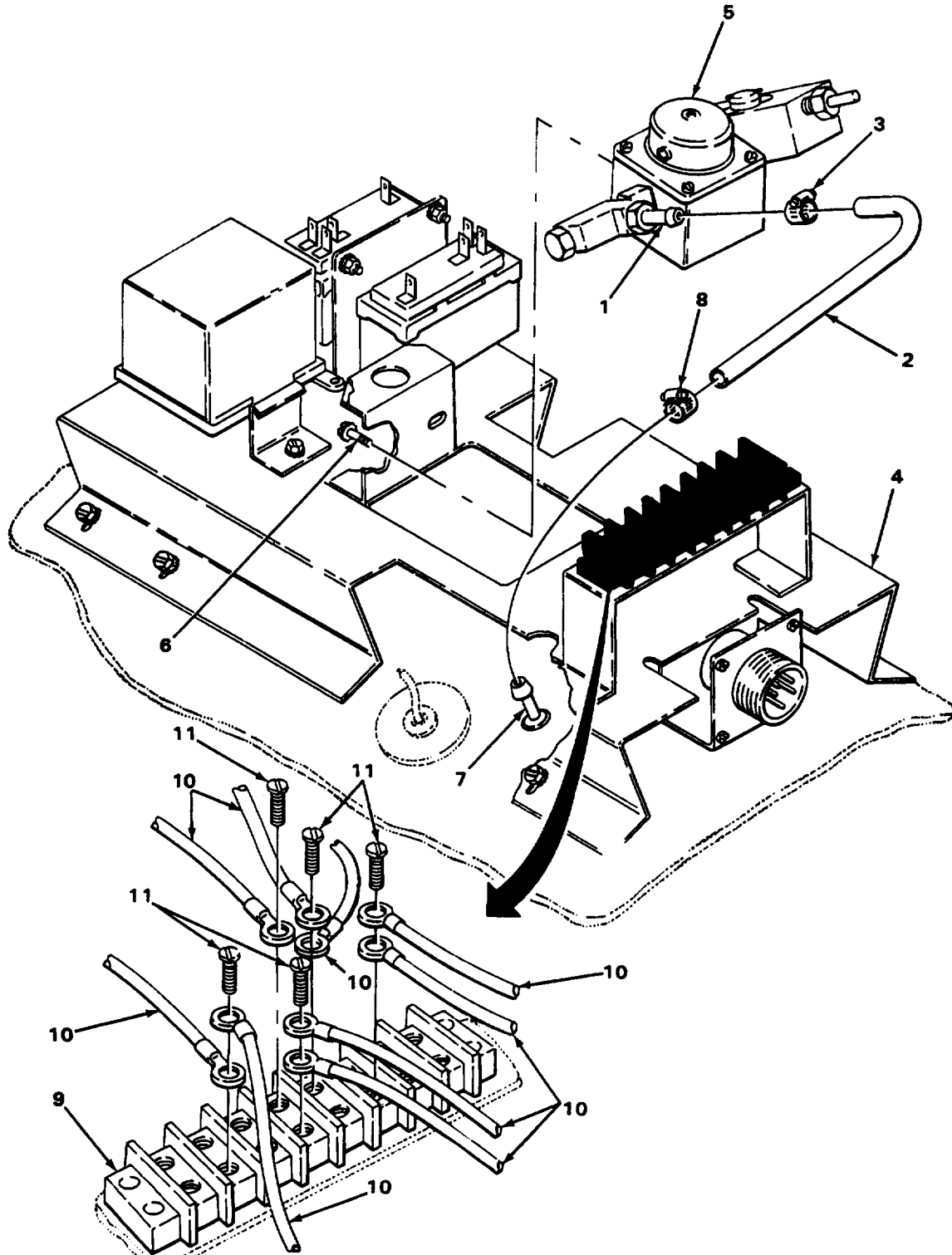

FUEL REGULATOR VALVE - HUPP MF510B, MF510C, MF60A-24V, MF60B-24V - Continued

LOCATION	ITEM	ACTION	REMARKS
----------	------	--------	---------

ADJUSTMENT

NOTE

You will need either a watch with a second hand or a stopwatch to perform these adjustments.

NOTE

If fuel hose to fuel connector is not connected, omit steps 34 and 35.

34. Fuel hose (1)	Clamp (2)	Unscrew part way.	
35. Fuel tube (3)	Fuel hose (1)	Remove.	

WARNING

The fuels these heaters run on are very explosive. Do not smoke or allow open flame nearby when performing these adjustments. serious injury or death to personnel could result if this warning is not observed.

36. Control box (4)	Hi/LO switch (5) and RUN/OFF/START switch (6)	<ol style="list-style-type: none"> a. Place end of fuel hose (1) in graduated cylinder. b. Place switch (5) in HI position. c. Place switch (6) in START position, and start timing fuel flow. d. Wait 60 seconds, and place switch (6) in OFF position. Wipe off any excess fuel that may have been spilled. e. Check table to see if fuel flow is within limits. f. Drain contents of graduated cylinder into drain-pan. 	
37. Fuel regulator valve (7)	Outer adjustment screw (8)	Adjust if fuel flow is not within limits. Turn clockwise to increase and counter-clockwise to decrease fuel flow. Repeat steps 35 and 36 until flow is within limits.	

FUEL REGULATOR VALVE - HUPP MF510B, MF510C, MF60A-24V, MF60B-24V - Continued

LOCATION	ITEM	ACTION	REMARKS
----------	------	--------	---------

ADJUSTMENT - Continued

FUEL	Cu. in./cc PER MINUTE
DF1 , DFA, JP8	2.1 to 2.5/43 to 49
DF2	2.2 to 2.6/41 to 46

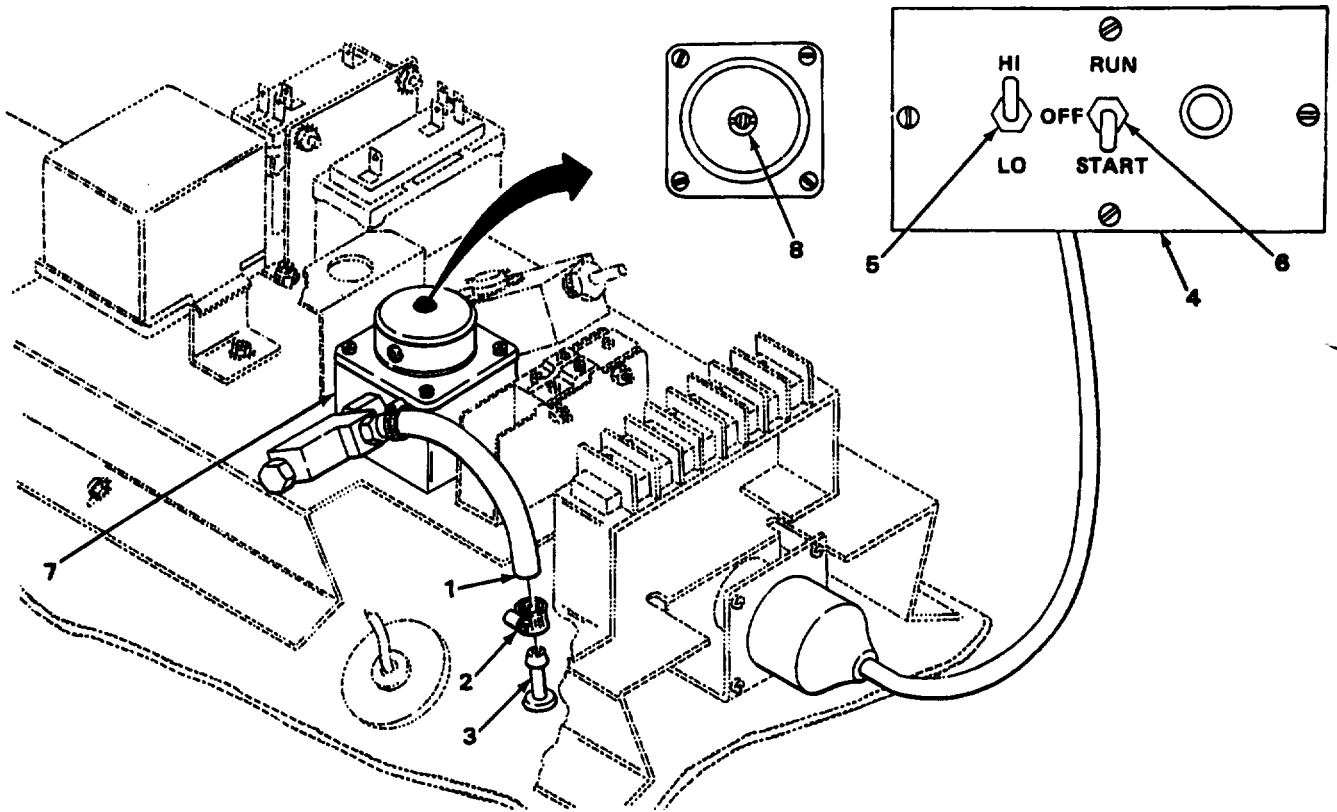

FUEL REGULATOR VALVE - HUPP MF510B, MF510C, MF50A-24V, MF60B-24V - Continued

LOCATION	ITEM	ACTION REMARKS
ADJUSTMENT - Continued		
38. Control box (1)	HI/LO switch (2) and RUN/START/OFF switch (3)	a. Place switch (2) in LO position. b. Place switch (3) in START position and start timing fuel flow. c. Wait 60 seconds and place switch (3) in OFF position. Wipe up any excess fuel that may have been Spilled. d. Checkable to see if fuel flow is within limits. e. Drain contents of graduated cylinder into drain pan and dispose of fuel in pan.
39. Fuel regulator valve (4)	inner adjustment screw (5)	Adjust if fuel flow is not within limits. Turn clockwise to increase and counter-clockwise to decrease fuel flow. Repeat steps 38 and 39 unit flow is within limits.
40.	Inner adjustment screw (5) and outer adjustment screw (6)	Apply sealant.
41. Fuel tube (7)	Fuel hose (8)	install.
42. Fuel hose (8)	Hose clamp (9)	Tighten.

FUEL	Cu. in./cc PER MINUTE
DF1, DFA, JP8	1.0 to 1.4/24 to 28
DF2	1.0 to 1.4/22 to 25

FUEL REGULATOR VALVE - HUPP MF510B, MF510C, MF60A-24V, MF60B-24V - Continued

LOCATION	ITEM	ACTION	REMARKS
----------	------	--------	---------

ADJUSTMENT - Continued

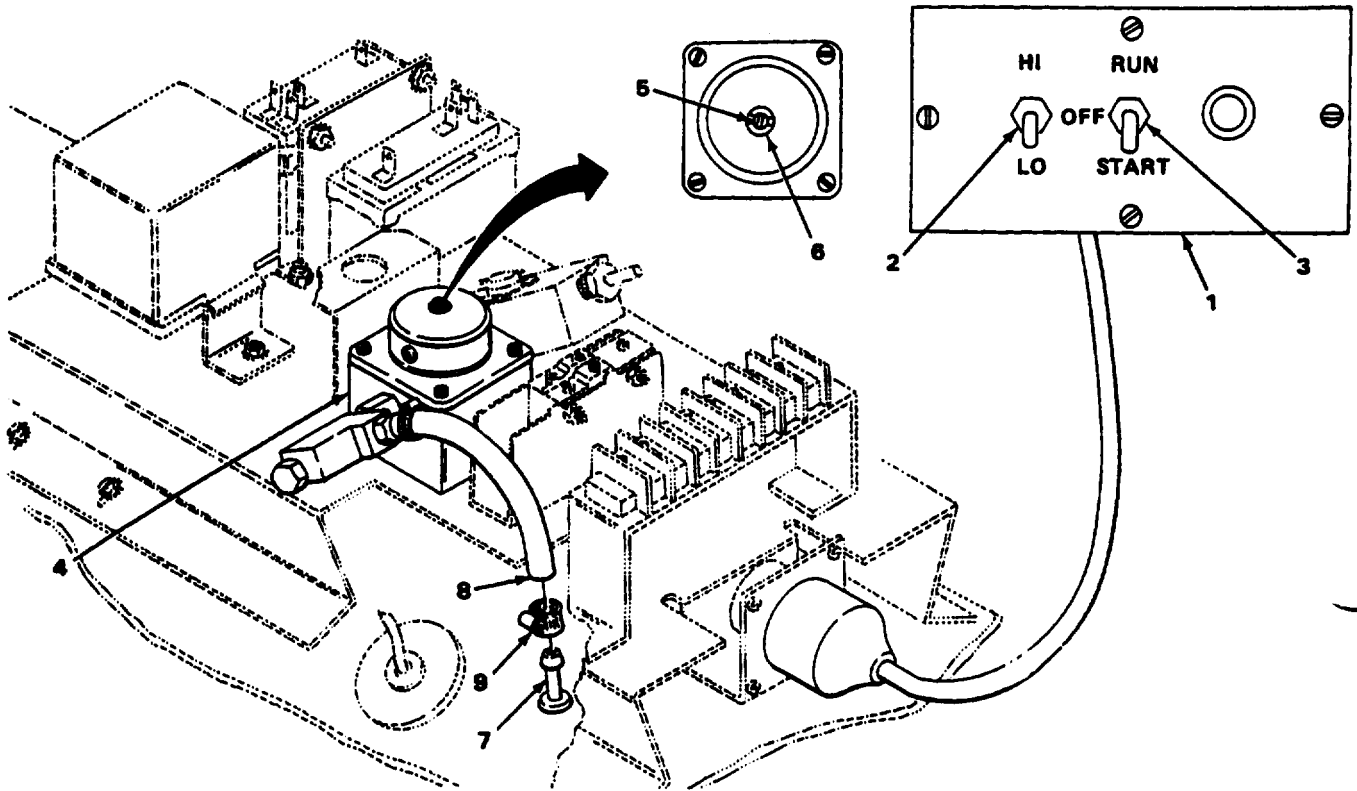

NOTE

FOLLOW-ON MAINTENANCE: Install guard (page 2-32)

TASK ENDS HERE

HEATER THERMOSTAT - HUPP MF510B, MF510C, MF60A-24V, MF60B-24V

This task covers:

- a. Removal
- b. Installation

INITIAL SETUP

Tools

Tool Kit, Mechanics Gen (Item 1, Appendix B)

Personnel Required

63G

Equipment Condition

Control bracket assembly removed (page 2-34)

LOCATION	ITEM	ACTION	REMARKS
----------	------	--------	---------

REMOVAL

- | | | |
|------------------------|--------------------------|---------------------|
| 1. Overheat switch (1) | Two screw assemblies (2) | Unscrew and remove. |
| 2. Heater (3) | Overheat switch (1) | Remove. |

INSTALLATION

- | | | |
|------------------------|--------------------------|-----------------------|
| 3. Heater (3) | Overheat switch (1) | Install. |
| 4. Overheat switch (1) | Two screw assemblies (2) | Screw in and tighten. |

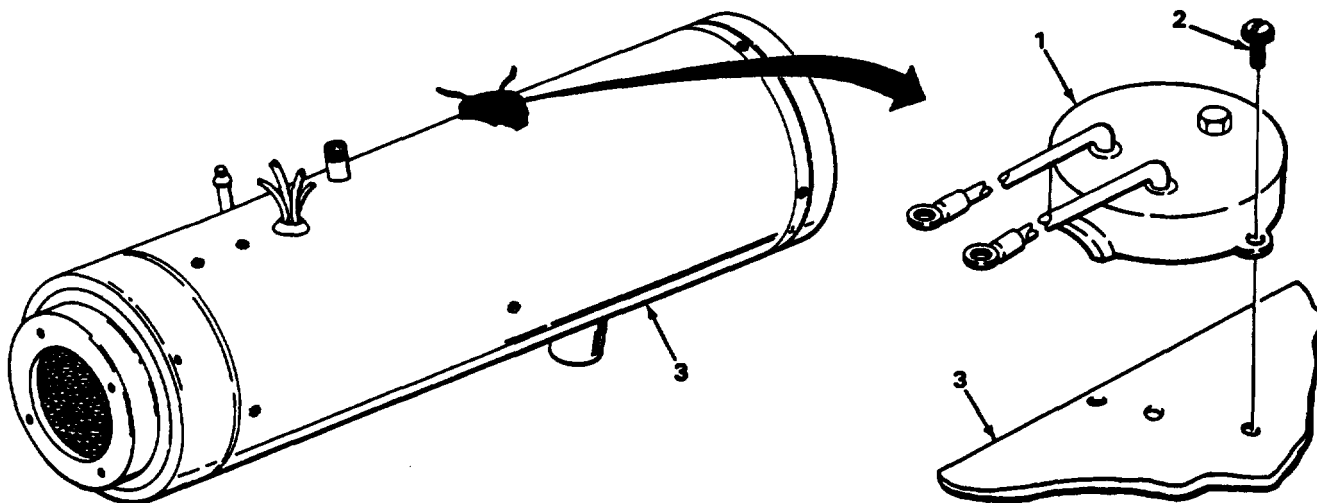

NOTE

FOLLOW-ON MAINTENANCE: Install control bracket assembly (page 3-34).

TASK ENDS HERE

BURNER THERMOSTAT/PREHEATER ASSEMBLY. HUPP MF510B, MF510C, MF60A.24V. MF60B.24V

This task covers:

- a. Removal
- b. installation

INITIAL SETUP

Tools

Tool Kit, Mechanics Gen (item 1, Appendix B)

Personnel Required

63G

Equipment Condition

Blower assembly removed (page 3-62)

LOCATION	ITEM	ACTION	REMARKS
----------	------	--------	---------

REMOVAL

- | | | |
|------------------------|--------------------------|---------------------|
| 1. Two studs (1) | Two nut assemblies (2) | Unscrew and remove. |
| 2. Burner plate (3) | Bracket (4) and lead (5) | Remove. |
| 3. Threaded collar (6) | Nut (7) | Unscrew and remove. |

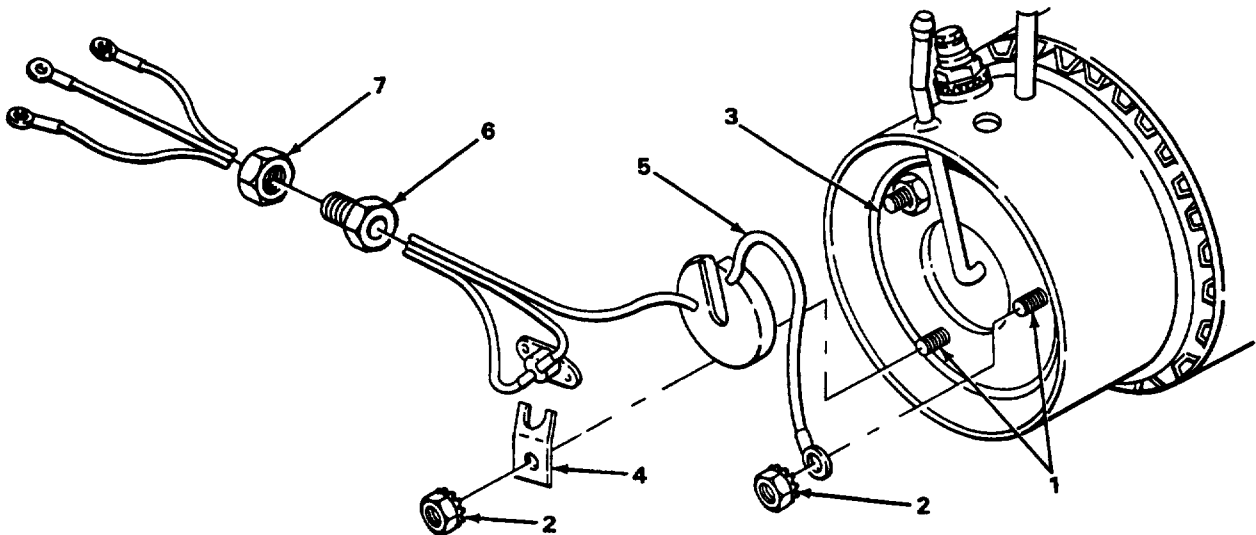

**BURNER THERMOSTAT/PREHEATER ASSEMBLY- HUPP MF510B, MF510C, MF60A-24V, MF60B-24V
-Continued**

LOCATION	ITEM	ACTION	REMARKS
----------	------	--------	---------

REMOVAL - CONTINUED

4. Combustion chamber(I)	Threaded collar (2)	Push in.	
5. Nut (3)	Three leads (4)	Pull through one at a time.	
6. Burner plate (5)	Burner thermostat (6) and preheater (7)	Remove.	

INSTALLATION

7. Combustion chamber (1)	Three leads (4)	Install from inside.	
8. Nut (3)	Three leads (4)	Put through.	
9. Threaded collar (2)	Nut (3)	Screw together and tighten.	
10. Burner plate (5)	Burner thermostat (6) and preheater (7)	Install.	
11.	Bracket (8) and lead (9)	Install.	
12. Two studs (10)	Two nut assemblies (11)	Screw on and tighten.	

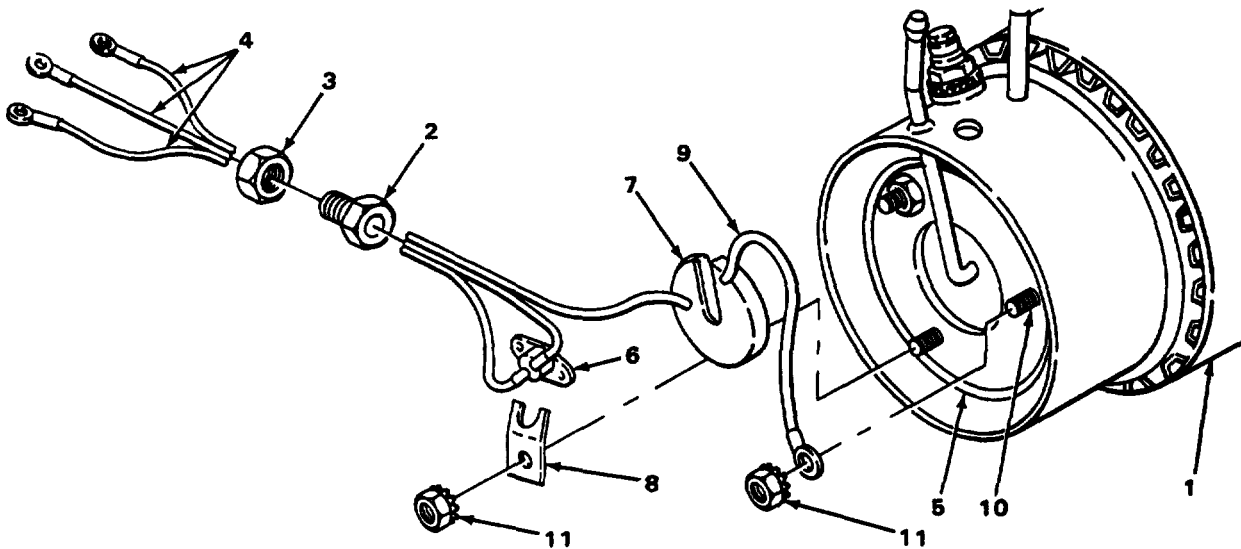

NOTE

FOLLOW-ON MAINTENANCE: Install blower assembly (page 3-62).

TASK ENDS HERE

BURNER PLATE - HUPP MF510B, MF510C, MF60A-24V, MF60B-24V

This task covers:

- | | |
|--|---|
| <ul style="list-style-type: none"> a. Removal b. Inspection/Cleaning | <ul style="list-style-type: none"> c. Installation |
|--|---|

INITIAL SETUP

<p>Tools</p> <p>Tool Kit, Mechanics Gen (Item 1, Appendix B)</p> <p>Materials/Parts</p> <p>Rags, wiping (Item 5, Appendix C) Solvent, drycleaning (Item 8, Appendix C)</p>	<p>Personnel Required</p> <p>63G</p> <p>Equipment Condition</p> <p>Burner thermostat/preheater removed (page 3-58) Igniter removed (page 2-35)</p>
--	--

LOCATION	ITEM	ACTION	REMARKS
----------	------	--------	---------

REMOVAL

1. Burner plate (1)	Nut assembly (2)	Unscrew and remove,
2. Inlet tube (3)	Nut (4)	Loosen.
3. Combustion chamber (5)	Burner plate (1)	Remove.
4. Burner plate (1)	Grommet (6)	Remove.

INSPECTION/CLEANING

NOTE

For more instructions on how to inspect and clean parts, go to General Maintenance Instructions (page 2-l).

WARNING

Drycleaning solvent PD-680 is both toxic and flammable. Wear protective goggles and gloves, and use only in well-ventilated area. Avoid contact with skin, eyes, and clothes, and don't breathe vapors. Do not use near open flame or excessive heat. The flashpoint is 100°F to 138°F (38°C to 59°C). If you become dizzy while using drycleaning solvent, get fresh air immediately, and get medical aid. If contact with eyes is made, wash your eyes with water, and get medical aid immediately.

5.	Burner plate (1)	<ul style="list-style-type: none"> a. Soak in solvent to loosen carbon. b. Wipe dry with clean, dry rags. c. Look for cracks, breaks, burned through areas, and signs of fuel leakage around fuel inlet tube. <p style="text-align: right;">Replace plate if damage is found.</p>
----	------------------	---

BURNER PLATE - HUPP MF510B, MF510C, MF60A-24V, MF60B-24V - Continued

LOCATION	ITEM	ACTION	REMARKS
----------	------	--------	---------

INSPECTION/CLEANING - Continued

6.	Combustion chamber (5)	a. Clean out carbon. b. Look for cracks and burned out areas. c. Look for cracked welds.	If damage is found, replace entire heater.
----	------------------------	--	---

INSTALLATION

7. Burner plate (1)	Grommet (6)	Install.	
8. Combustion Chamber(5)	Burner plate (1)	a. Install. b. Push onto studs.	Insert tube on fuel tube.
9. Inlet tube (3)	Nut (4)	a. Tighten by hand. b. Tighten another 1/2-turn.	
10. Burner plate (1)	Nut assembly (2)	Screw in and tighten.	

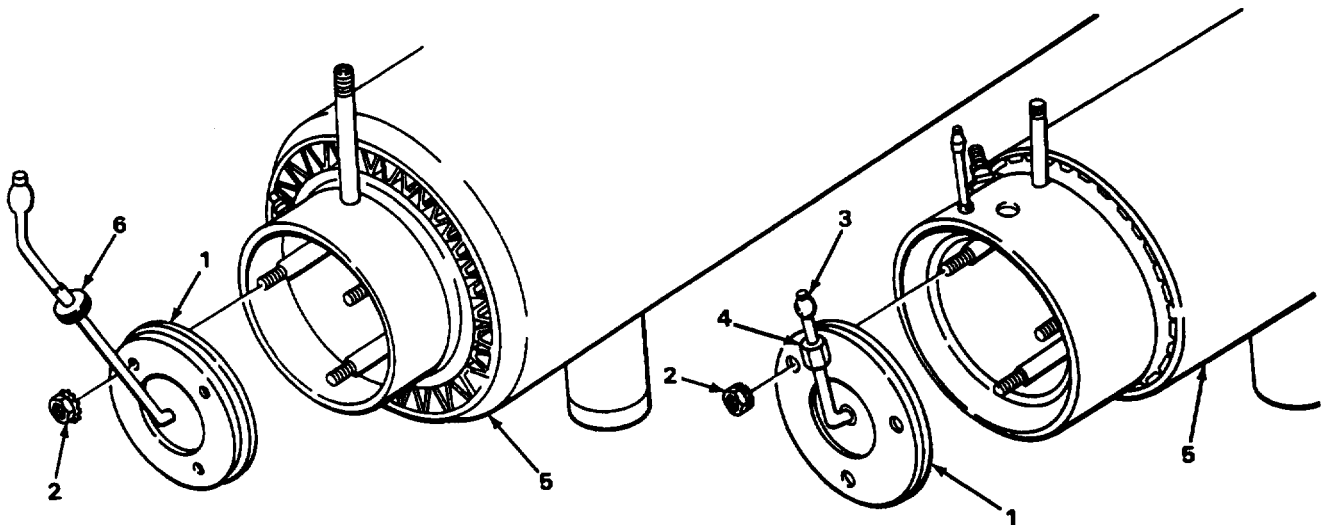

NOTE

FOLLOW-ON MAINTENANCE: Install igniter (page 2-35) and install burner thermostat/preheater assembly (page 3-58).

TASK ENDS HERE

BLOWER ASSEMBLY - HUPP MF510B, MF510C, MF60A-24V, MF60B-24V

This task covers:

- | | |
|----------------|-----------------|
| a. Removal | c. Assembly |
| b. Disassembly | d. Installation |

INITIAL SETUP

Tools	Personnel Required
Tool Kit, Mechanics Gen (Item 1, Appendix B) Key, socket-head screw, 3/32-inch (Item 2, Appendix B)	63G
Materials/Parts	Equipment Condition
Sealant, silicon (Item 6, Appendix C)	Control bracket assembly removed (page 3-34) Overheat switch removed (page 3-57)

LOCATION	ITEM	ACTION REMARKS
----------	------	-------------------

REMOVAL

1. Duct and elbow assembly (1)	Two screw assemblies (2)	Unscrew and remove.
2. Top cover (3) and bottom cover (4)	Duct and elbow assembly (1)	Lift up and remove.
3. Duct and elbow assembly (1)	Elbow (5)	a. Cut sealant. b. Remove.
4. Duct (6) and housing (7)	Two screw assemblies (8)	Unscrew and remove.
NOTE		
Step only applies to new models.		
5. Duct assembly (1)	Cover (9), gasket (10), housing (7), and gasket (11)	Remove.
6. Housing (7)	Duct (6)	Bend back tabs and separate.
7. Top cover (3) and bottom cover (4)	Four screw assemblies (12) and intake cover (13)	a. Unscrew and remove b. Remove cover (13).

BLOWER ASSEMBLY - HUPP MF510B, MF510C, MF60A-24V, MF60B-24V - Continued

LOCATION	ITEM	ACTION
REMARKS		

REMOVAL - Continued

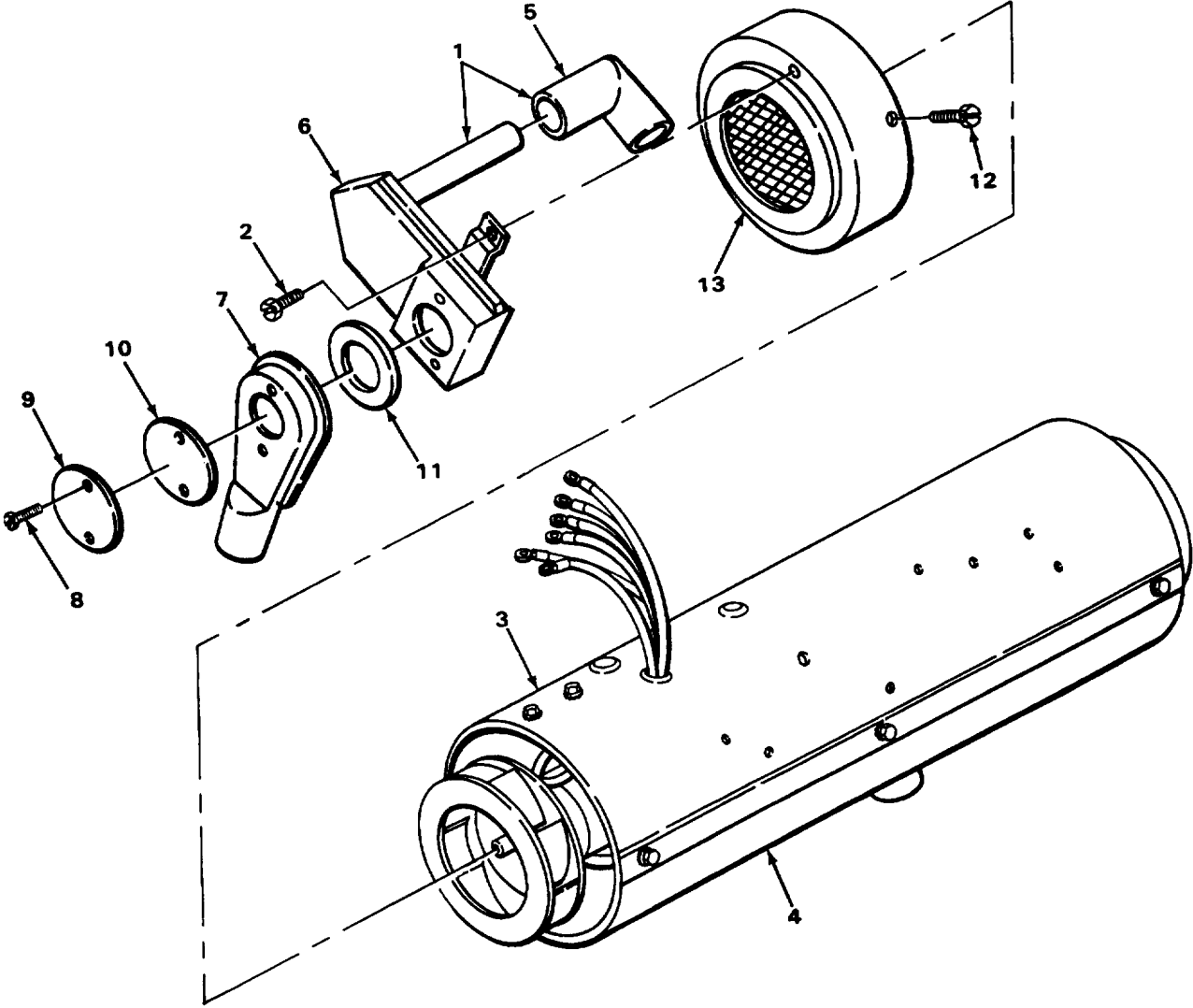

8. Top cover (1) and bottom cover (2)	Four screw assemblies (3) and exhaust adapter (4)	a. Unscrew and remove. b. Remove adapter (4).
9. Bottom cover (2) and exhaust shield (5)	Eight screw assemblies (6)	Unscrew and remove.

BLOWER ASSEMBLY - HUPP MF510B, MF510C, MF60A-24V, MF60B-24V - Continued

LOCATION	ITEM	ACTION	REMARKS
REMOVAL - Continued			
10. Combustion chamber (7)	Top cover (1), grommet (8), and six leads (9)	a. Lift top cover (1). b. Pull leads (9) through grommet (8) one at a time. c. Remove top cover (1).	
11. Top cover (1)	One grommet (8) and two grommets (10)	Remove.	
12. Bottom cover (2)	Combustion chamber (7)	Remove.	
13. Combustion chamber (7)	Exhaust shield (5)	Remove.	
14.	Four screw assemblies (11)	a. Peel away sealant. b. Unscrew and remove.	
15.	Blower assembly (12)	a. Cut through sealant. b. Remove.	

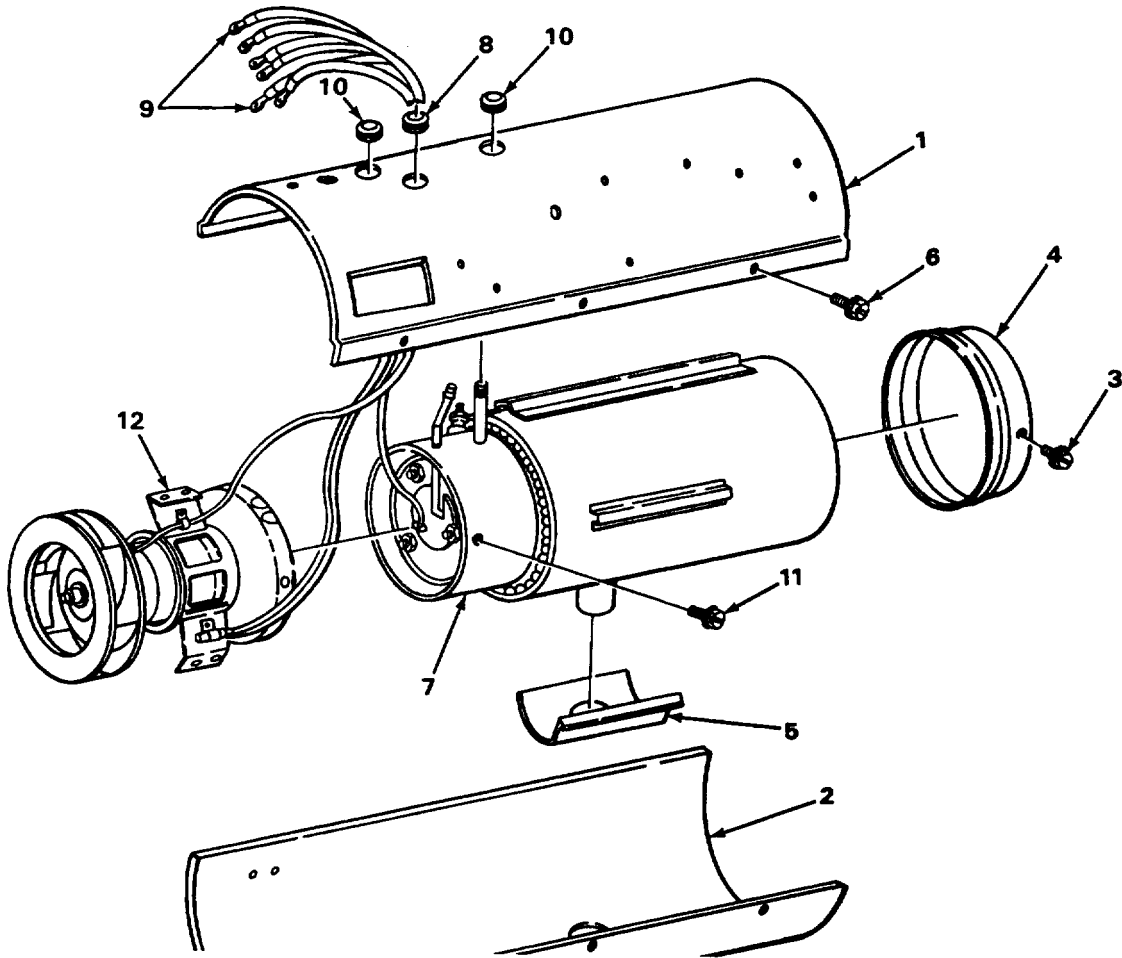

BLOWER ASSEMBLY- HUPP MF510B, MF510C, MF60A-24V, MF60B-24V - Continued

LOCATION	ITEM	ACTION REMARKS
DISASSEMBLY		
16. Ventilation blower wheel (1)	Setscrew (2)	Unscrew part way.
17. Motor (3)	Ventilation blower wheel (1)	Remove.
18. Combustion blower wheel (4)	Setscrew (5)	a. Rotate blower wheel (4) to access setscrew (5). b. Unscrew partway.
19. Motor (3)	Combustion blower wheel (4)	Remove.
20. Support (6)	Screw assembly (7), nut assembly (8), and cable clamp (9)	Unscrew and remove.
21. Lead (10)	Clamp (9)	Remove.
22. Shell (11) and duct (12)	Four screw assemblies (13)	a. Mark position prior to removal. b. Unscrew and remove.
23. Motor (3)	Shell (11) and duct (12)	Remove.
24.	Support (6)	a. Mark position of motor (3) to Support (6). b. Remove.
25. Clamp (14) and support (6)	Screw assembly (15) and nut assembly (16)	Unscrew and remove.
26. support (6)	Clamp (14) with resistor (17)	Remove.
27. Resistor (17)	Clamp (14)	Remove.

BLOWER ASSEMBLY - HUPP MF510B, MF510C, MF60A-24V, MF60B-24V - Continued

LOCATION	ITEM	ACTION	REMARKS
----------	------	--------	---------

DISASSEMBLY - Continued

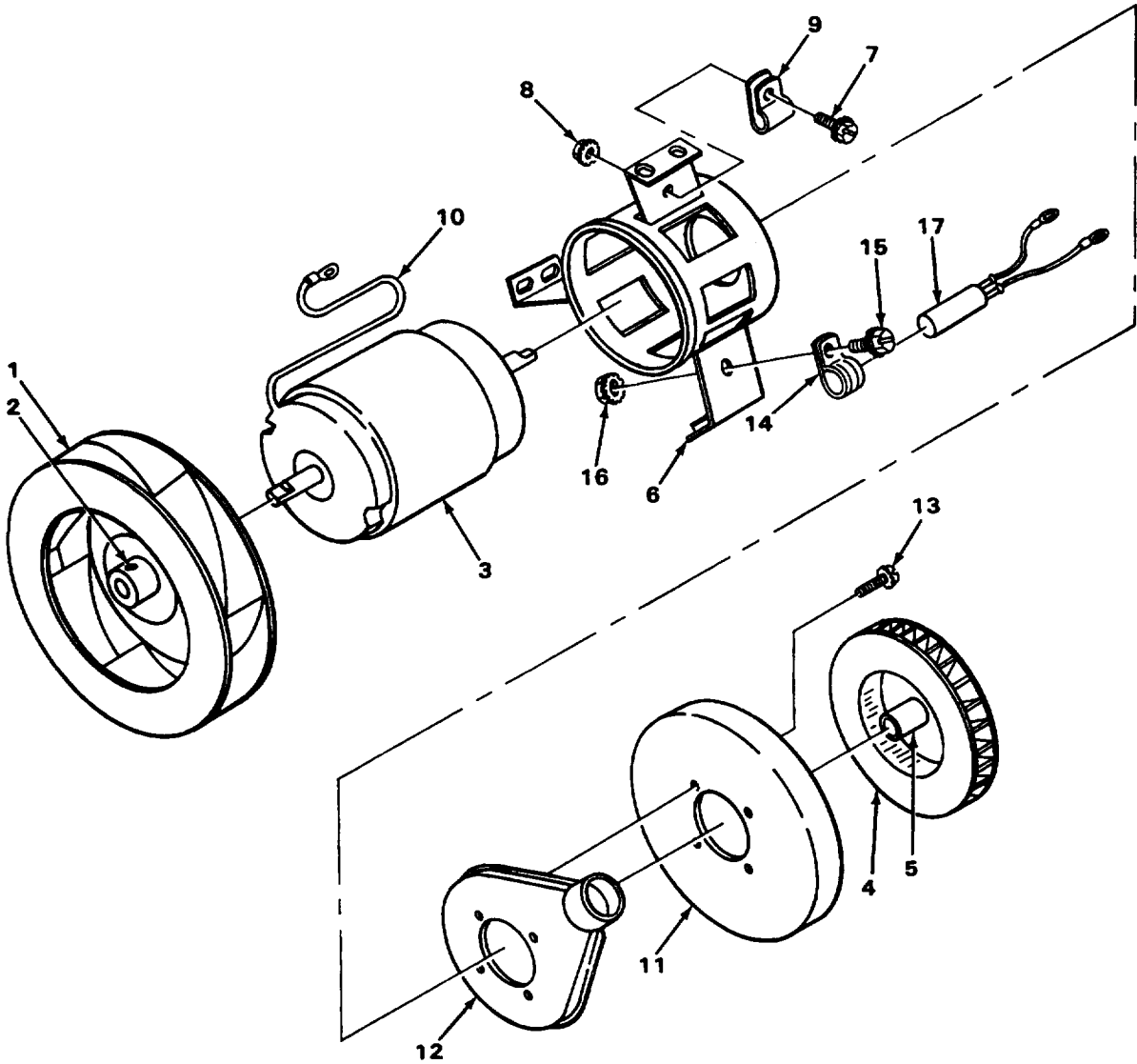

BLOWER ASSEMBLY - HUPP MF510B, MF510C, MF60A-24V, MF60B-24V - Continued

LOCATION	ITEM	ACTION REMARKS
ASSEMBLY		
28. support (1)	Motor (2)	Note markings and place in position.
29.	Duct (3) and shell (4)	a. APPLY sealant to each side. b. Place in position.
30.	Four screw assemblies (5)	Screw in and tighten.
31.	Cable clamp (6), screw assembly (7), and nut assembly (8)	a. Place clamp (6) around lead (9). b. Place clamp (6) in position. c. Screw in and tighten.
32. Motor (2)	Combustion blower wheel (10)	a. Push on until setscrew(11) is lined up with flat on shaft. b. Pull off until wheel (10) turns freely.
33. Combustion blower wheel (1 O)	Setscrew (11)	a. Rotate blower wheel (10) to access setscrew (11). b. Screw in and tighten.
34. Motor (2)	Ventilation blower wheel (12)	a. Push on as far as possible with flat lined up with setscrew (13). b. Pull off until wheel (12) turns freely.
35. Ventilation blower wheel (12)	Setscrew (13)	Screw in and tighten.
36. Resistor (14)	Clamp (15)	Install.
37. support (1)	Clamp (15) with resistor (14)	Install.
38. Clamp (15) and support (1)	Screw assembly (16) and nut assembly (17)	Screw in and tighten.

BLOWER ASSEMBLY - HUPP MF510B, MF510C, MF60A-24V, MF60B-24V - Continued

LOCATION	ITEM	ACTION	REMARKS
----------	------	--------	---------

ASSEMBLY - Continued

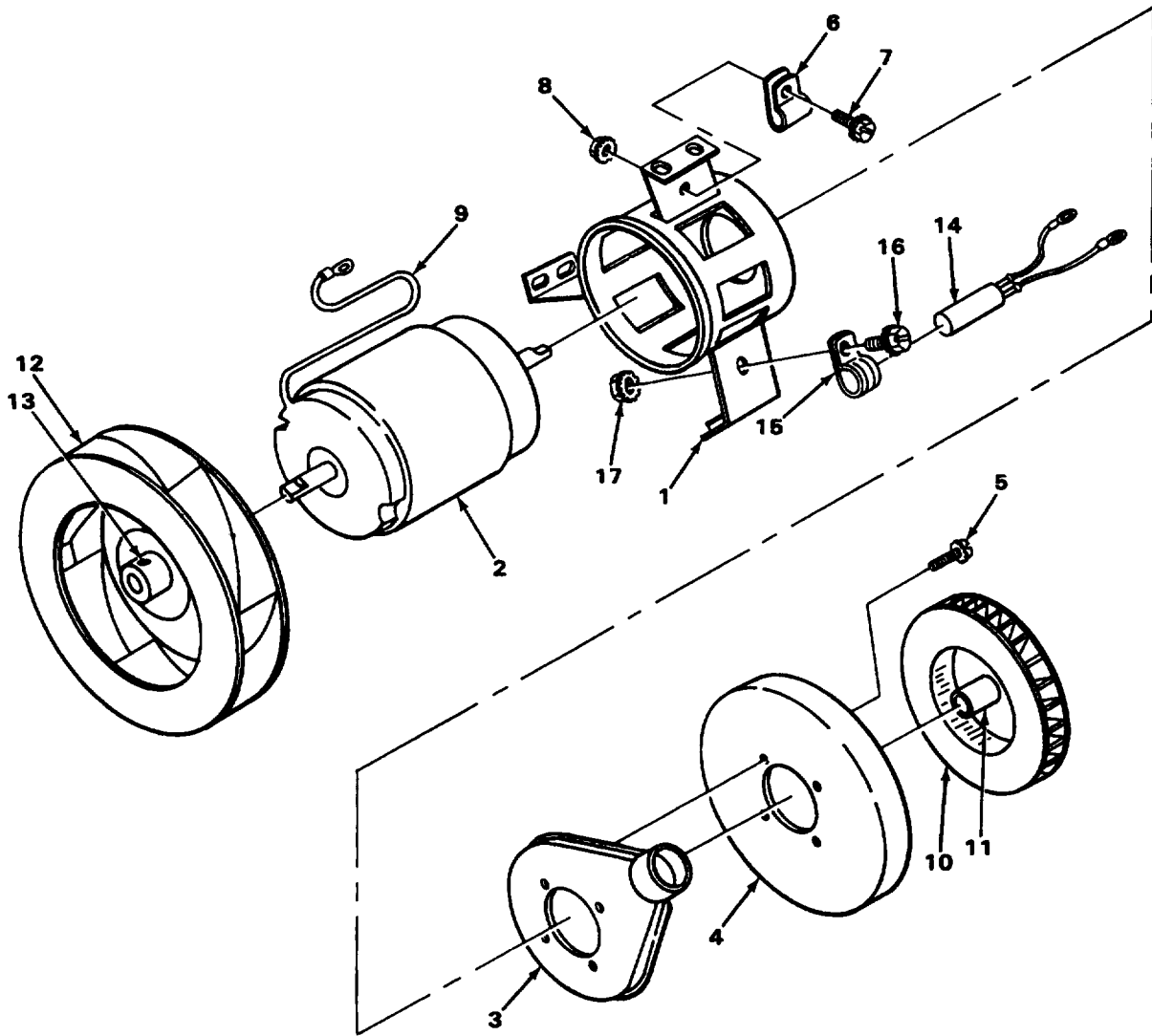

BLOWER ASSEMBLY - HUPP MF510B, MF510C, MF60A-24V, MF60B-24V - Continued

LOCATION	ITEM	ACTION REMARKS
INSTALLATION		
39. Combustion chamber (1)	Blower assembly (2)	a. Apply sealant to inside of rim. b. Install.
40. Blower assembly (2) and combustion chamber (1)	Four screw assemblies (3)	Screw in and tighten.
41.	Four screw assemblies (3) and joint between blower assembly (2) and combustion chamber (1)	Apply sealant,
42. Top cover (4)	Three grommets (5)	Install.
43. Grommet (5)	Six leads (6)	Push through from bottom.
44. Combustion chamber (1)	Top cover (4)	a. Press down into position. b. Turn chamber (1) upside down.
45.	Exhaust shield (7) and bottom cover (8)	Install.
46. Top cover (4) and bottom cover (8)	Two screw assemblies (9)	Screw in and tighten.
47.	Six screw assemblies (10)	Screw in and tighten.
48.	Inlet rover (11) and exhaust adapter (12)	a. Install. b. Aline all screw holes. c. Push in.
49. Inlet cover (11) and exhaust adapter (12)	Eight screw assemblies (13)	Screw in and tighten.

NOTE

Steps 50 and 51 only apply to MF510B.

50.	Duct and elbow assembly (14)	install.
51. Duct (14)	Two screw assemblies (15)	Screw in and tighten.

NOTE

Steps 52 through 54 only apply to MF51C, MF60A-24V, and MF60B-24V.

BLOWER ASSEMBLY - HUPP MF510B, MF510C, MF60A-24V, MF60B-24V - Continued

LOCATION	ITEM	ACTION	REMARKS
----------	------	--------	---------

INSTALLATION - Continued

52. Duet (14)	Gasket (16) and housing (17)	a. Install. b. Bend tabs back over housing (17).	
---------------	------------------------------	---	--

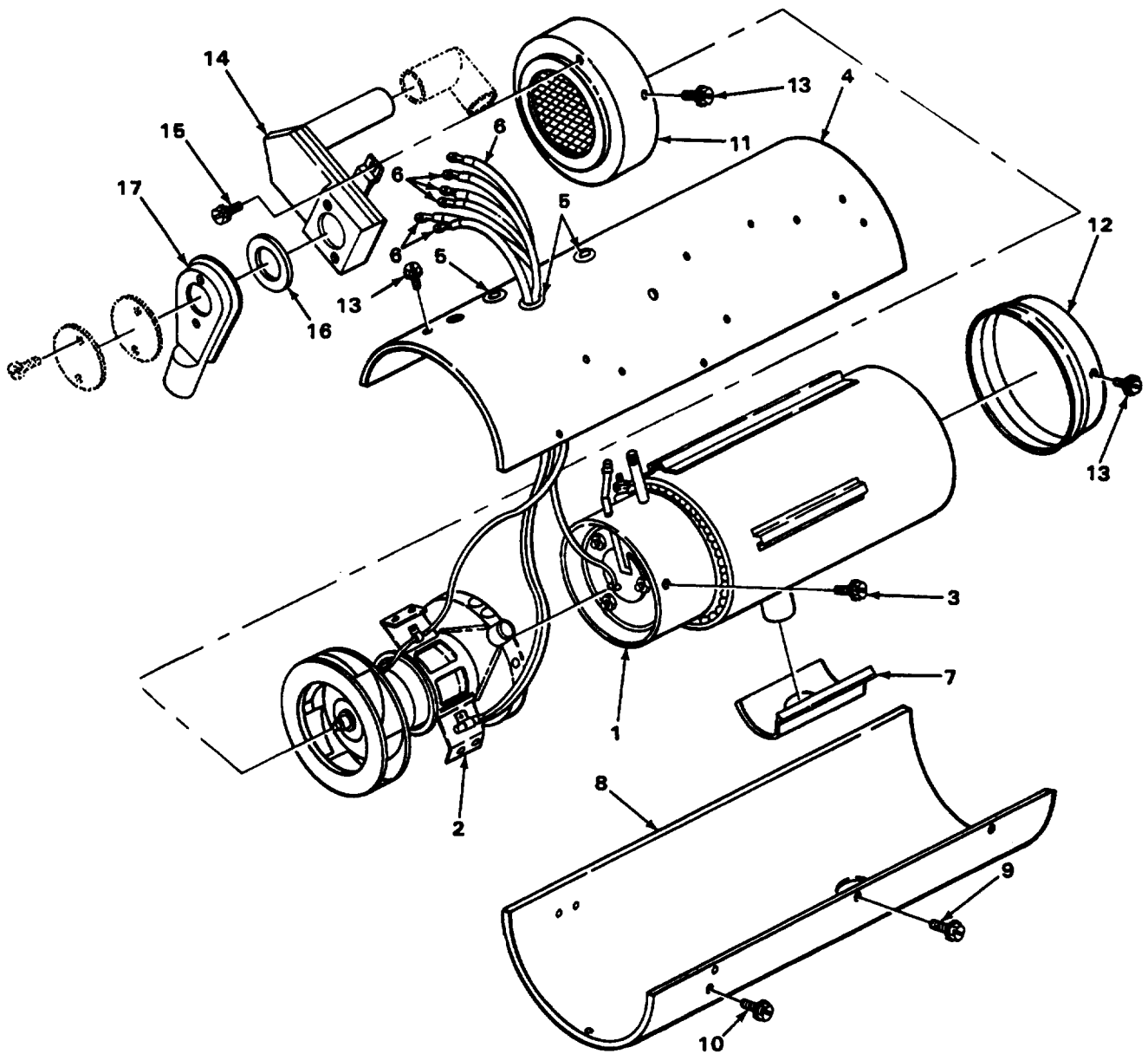

BLOWER ASSEMBLY - HUPP MF510B, MF510C, MF60A-24V, MF60B-24V - Continued

LOCATION	ITEM	ACTION	REMARKS
----------	------	--------	---------

INSTALLATION - Continued

53. Housing (1)	Gasket (2) and cover (3)	Install.	
54. Cover (3)	Two screw assemblies (4)	Screw in and tighten.	

NOTE

Step 55 through 57 apply to MF510B, MF510C, and MF60B-24V.

55. Heater (5)	Elbow (6)	a. Apply sealant. b. Install.	
56. Elbow (6) and inlet cover (7)	Duct assembly (8)	a. Apply sealant. b. Install.	
57. Duct assembly (8) and inlet cover (7)	Two screw assemblies (9)	Screw in and tighten.	

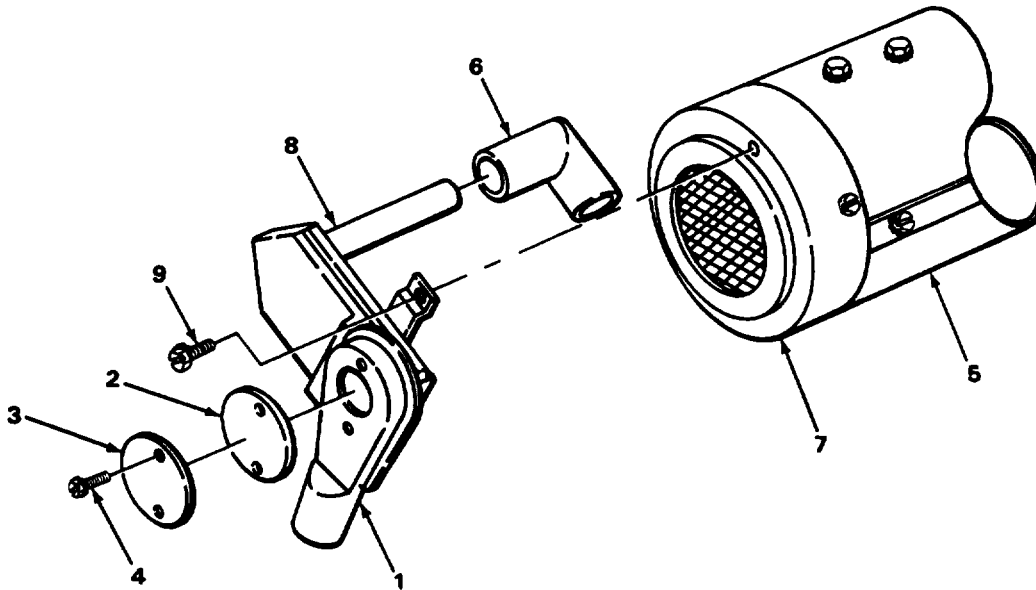

NOTE

FOLLOW-ON MAINTENANCE:

1. Install overheat switch (page 3-57).
2. Install control bracket assembly (page 3-37).

TASK ENDS HERE

THERMOSTATIC SWITCH (FLAME DETECTOR SWITCH) REPAIR - STEWART-WARNER 10560C24, 10560M, 10560M24BI, 10560G

This task covers:

- a. Disassembly
- b. Assembly

INITIAL SETUP

Tools	Personnel Required
Tool Kit, Mechanics Gen (Item 1, Appendix B)	63G
	Equipment Condition
	Flame detector switch removed (page 2-43)

LOCATION	ITEM	ACTION	REMARKS
----------	------	--------	---------

DISASSEMBLY

- | | | |
|------------------------------|---|----------------------|
| 1, Flame detector switch (1) | Adjusting screw (2), spring (3), and self-locking nut (4) | Unscrew and remove. |
| 2. | Switch (1) | Swing back on pivot. |

CAUTION

Be careful when handling rod. It is easily broken.

- | | | |
|----|-----------------|---------|
| 3. | Ceramic rod (5) | Remove. |
|----|-----------------|---------|

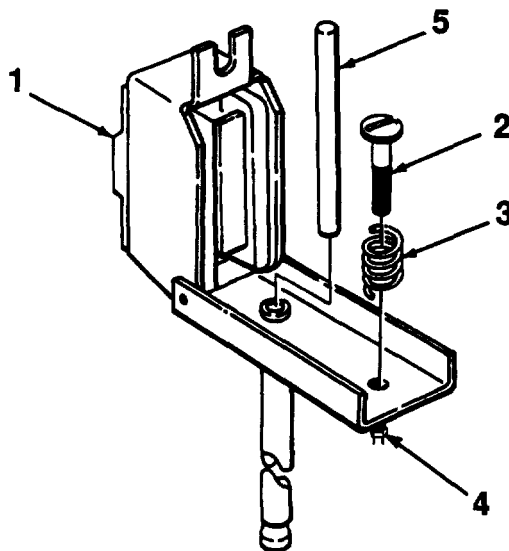

THERMOSTATIC SWITCH (FLAME DETECTOR SWITCH) REPAIR - STEWART-WARNER 10560C24, 10560M, 10560M24B1, 10560G - Continued

LOCATION	ITEM	ACTION	REMARKS
ASSEMBLY			
4.	Flame detector switch (1)	Ceramic rod (2)	Install.
5.		Flame detector switch (1)	Install.
6.		Spring (3)	Install.

CAUTION

Do not overtighten adjusting screw. Ceramic rod is easily damaged.

7.	Adjusting screw (4) and self-locking nut (5)	Screw in until switch (1) touches rod (2).
----	--	--

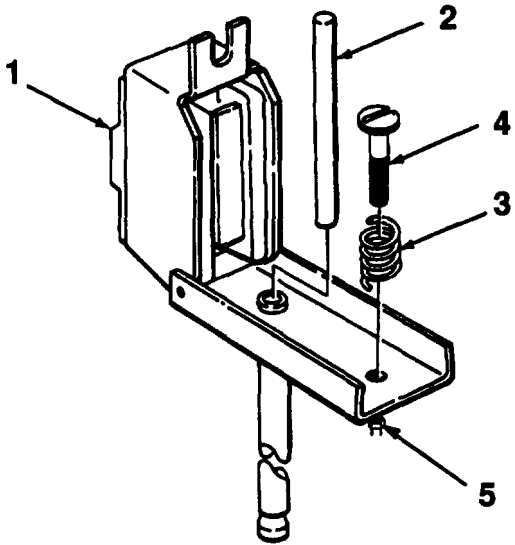

NOTE

FOLLOW-ON MAINTENANCE: Install and adjust flame detector switch (page 2-43, 2-44).

TASK ENDS HERE

FUEL REGULATOR VALVE - STEWART-WARNER 10560C24, 10560M

This task covers:

- | | |
|---------------------------|-----------------|
| a. Removal | e. Assembly |
| b. Disassembly | f. Installation |
| c. Cleaning | g. Adjustment |
| d. Inspection/Replacement | |

INITIAL SETUP

<p>Tools</p> <p>Tool Kit, Mechanics Gen (Item 1, Appendix B)</p> <p>Materials/Parts</p> <p>Cylinder, graduated, 100cc capacity Hose, rubber, 12-inch (two required) Pan, drain Parts Kit, valve Rags, wiping (Item 5, Appendix C) Sealant, silicon (Item 6, Appendix C) Solvent, drycleaning (Item 8, Appendix C) Stripper, wire Tie wraps (two required) (Item 11, Appendix C) Tool, crimping</p>	<p>Personnel Required</p> <p>63G</p> <p>Equipment Condition</p> <p>Ignition control removed (page 2-47) Remove wire lead from thermostat to terminal (page 2-55)</p>
--	--

LOCATION	ITEM	ACTION	REMARKS
----------	------	--------	---------

REMOVAL

NOTE

Tag all wires and terminals to aid during installation (page 2-3).

NOTE

Newer valves have different cover in which wire does not go through a hole.

<p>1. Fuel tube (1) and tee (2)</p> <p>2. Fuel regulator valve (4)</p> <p>3. Terminal strip (6)</p> <p>4. Overheat switch (9)</p> <p>5. Fuel regulator valve (4) and heater (12)</p> <p>6. Heater (12)</p>	<p>Nut (3)</p> <p>Two tie wraps (5)</p> <p>Screw assembly (7) and lead (8)</p> <p>Nut assembly (1 O) and lead(11)</p> <p>Three screw assemblies (13)</p> <p>Fuel regulator valve (4)</p>	<p>a. Position drain pan to catch fuel. b. Loosen, drain and disconnect.</p> <p>a. Remove. b. Discard.</p> <p>Unscrew and remove.</p> <p>Unscrew and remove.</p> <p>Unscrew and remove.</p> <p>Remove.</p>
--	---	--

FUEL REGULATOR VALVE - STEWART-WARNER 10560C24, 10560M - Continued

LOCATION	ITEM	ACTION	REMARKS
----------	------	--------	---------

DISASSEMBLY

7. Cover (14)	Screw assembly (15)	Unscrew and remove.	
8. Case (16)	Cover (14), coil (17), and cork washer (18)	Remove.	

NOTE

Do not perform steps 9 and 10 unless cover and coil are to be replaced.

9. Lead(11)	Terminal (19)	Remove.	
10. Lead (11) and coil (17)	Cover (14)	Remove.	

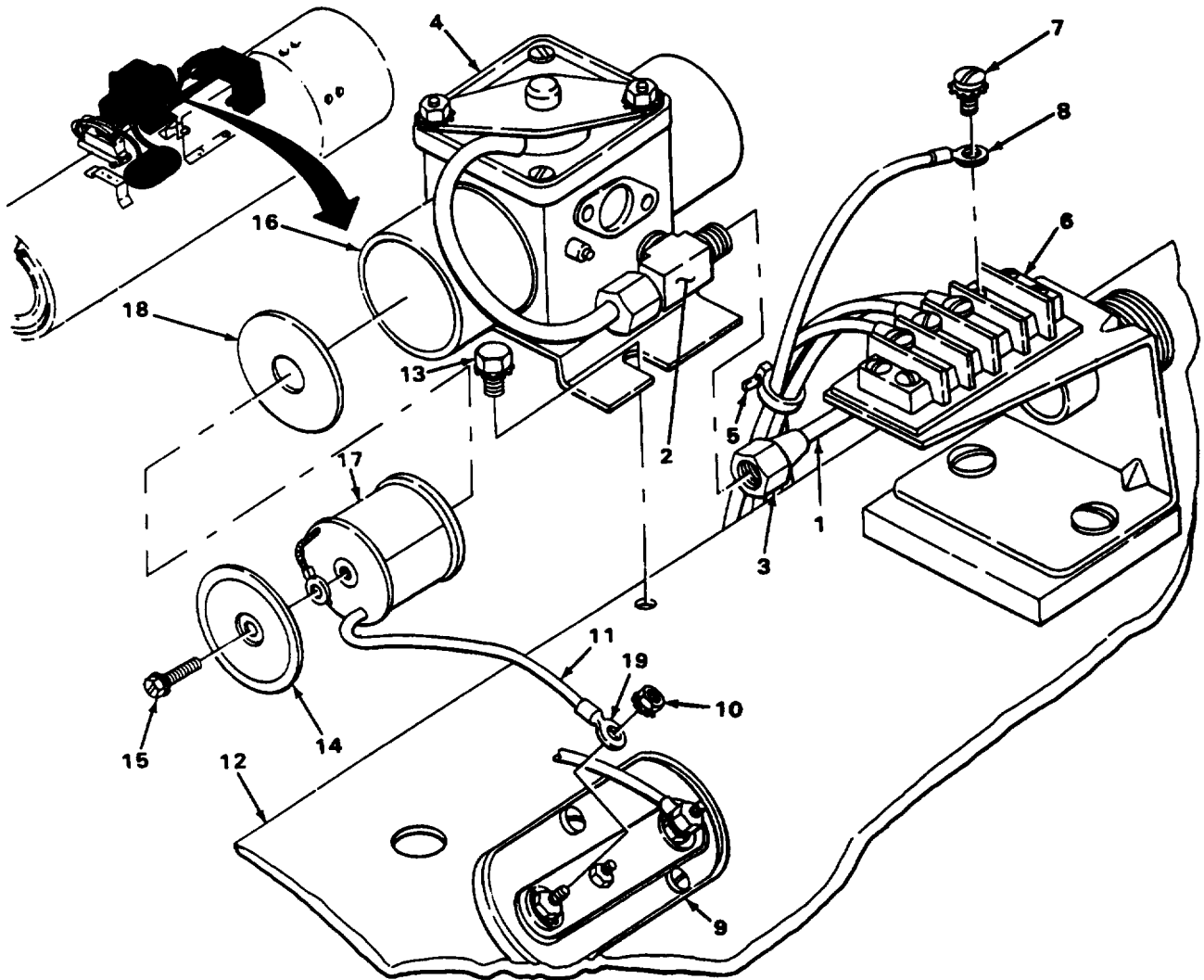

FUEL REGULATOR VALVE - STEWART-WARNER 10560C24, 10560M - Continued

LOCATION	ITEM	ACTION REMARKS
DISASSEMBLY - Continued		
11. Case (1) and valve body (2)	Three screws (3)	Unscrew and remove.
12. Valve body (2)	Case (1)	Remove slowly.
13. Gasket (4)	Core assembly (5), spring (6), and plunger assembly (7)	Remove and separate.
14. Valve body (2)	Gasket (4)	a. Remove. b. Discard. c. Repeat steps 7 thru 14 b for other side.
15. Mounting bracket (8) and valve body (2)	Four screws (9)	Unscrew and remove.
16. Valve body (2)	Mounting bracket (8)	Remove.
17. Two plates (10)	Three screws (11)	Unscrew and remove.
18. Plate (12)	Two plates (10)	Remove and separate.
19. Plate (13)	Plate (14) with packing (15)	Remove.
20. Plate (14)	Packing (15)	a. Remove. b. Discard.
21. Valve body (2)	Plate (13)	Remove.
22.	Three packings (16)	a. Remove. b. Discard.
23. Retainer (17) and two studs(19)	Two nut assemblies (19)	Unscrew and remove.

FUEL REGULATOR VALVE - STEWART-WARNER 10560C24, 10560M - Continued

LOCATION	ITEM	ACTION	REMARKS
----------	------	--------	---------

DISASSEMBLY - Continued

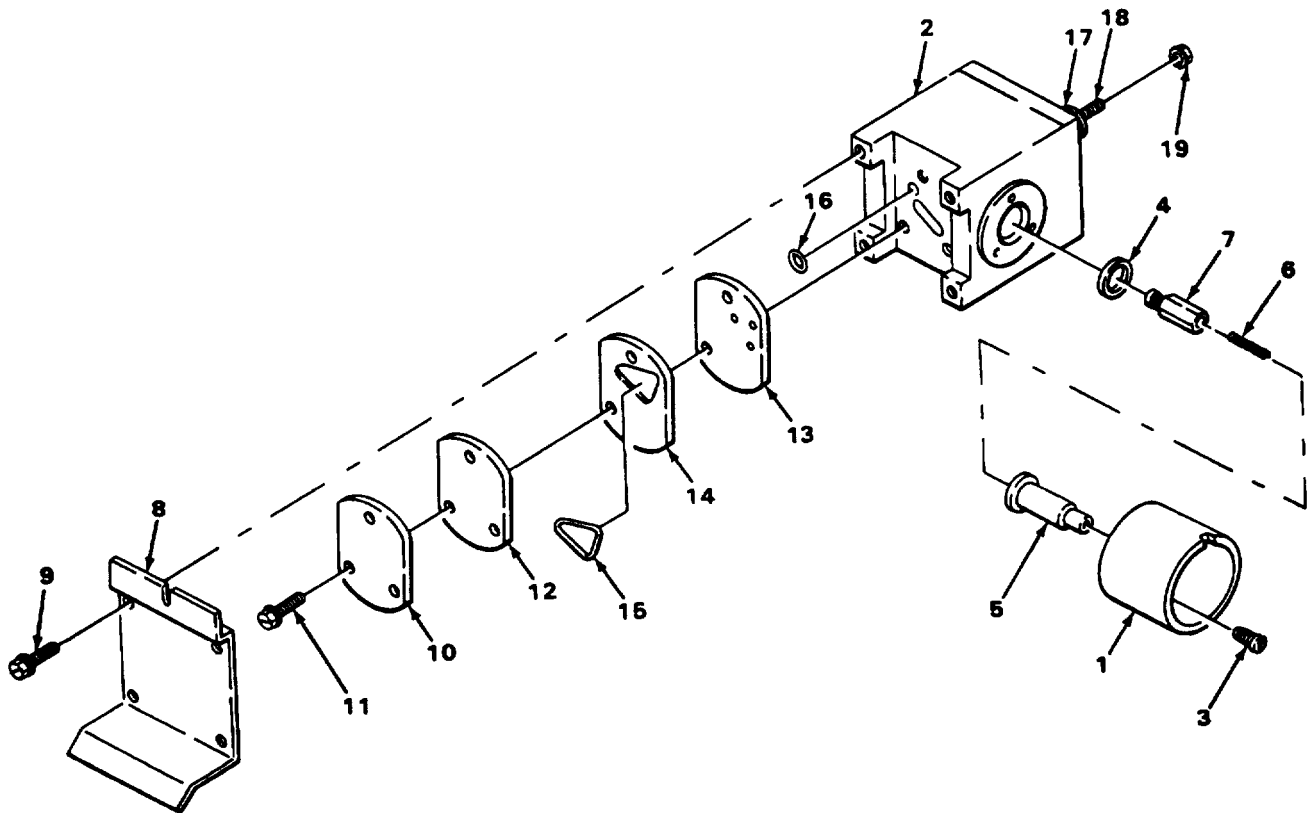

FUEL REGULATOR VALVE - STEWART-WARNER 10560C24, 10560M - Continued

LOCATION	ITEM	ACTION REMARKS
DISASSEMBLY - Continued		
24. Cover (1) and two studs (2)	Retainer (3)	Remove.
25. Gasket (4)	Cover (1)	Remove. Gasket (4) may stick to cover(1).
26. Bypass assembly (5)	Gasket (4)	a. Remove. b. Discard.
27. Bypass assembly (5) and tee (6)	Nut (7)	Unscrew until threads are free.
28. Bypass assembly (5)	Two studs (2)	Unscrew and remove.
29.	Adjusting screw (8)	Unscrew and remove.
30. Diaphragm (9)	Spring (10)	Remove.
31. Bypass assembly (5)	Two screws (11)	Unscrew and remove.
32.	Bypass assembly (5)	Remove.
33. Valve body (12)	Diaphragm (9)	a. Remove. b. Discard.
34.	Packing (13)	a. Remove. b. Discard.
35.	Valve core (14)	Unscrew and remove.
36.	Bleeder valve (14)	Unscrew and remove.
37.	Inlet screen (16)	Remove.
38.	Tee (6)	a. Put valve body (12) in vise equipped with jaw caps. b. Unscrew and remove. c. Take valve body (12) out of vise.

CLEANING

NOTE

For further information on cleaning parts, see General Maintenance Instructions (page 2-l).

FUEL REGULATOR VALVE - STEWART-WARNER 10560C24, 10560M - Continued

LOCATION	ITEM	ACTION	REMARKS
----------	------	--------	---------

CLEANING - Continued

WARNING

Dry cleaning solvent PD-680 is both toxic and flammable. Wear protective goggles and gloves, and use only in well-ventilated area. Avoid contact with skin, eyes, and clothes, and don't breathe vapors. Do not use near open flame or excessive heat. The flashpoint is 100°F to 138°F (38°C to 59°C). If you become dizzy while using dry cleaning solvent, get fresh air immediately, and get medical aid. If contact with eyes is made, wash your eyes with water, and get medical aid immediately.

39.	All metal parts	a. Wipe with solvent-dampened cloth. b. Wipe with clean, dry rags. c. Allow to dry.	
-----	-----------------	---	--

INSPECTION/REPLACEMENT

NOTE

For further information on inspecting parts, see General Maintenance Instructions (page 2-1).

40.	All parts	Look for cracks, dents, chips or other damage.	
-----	-----------	--	--

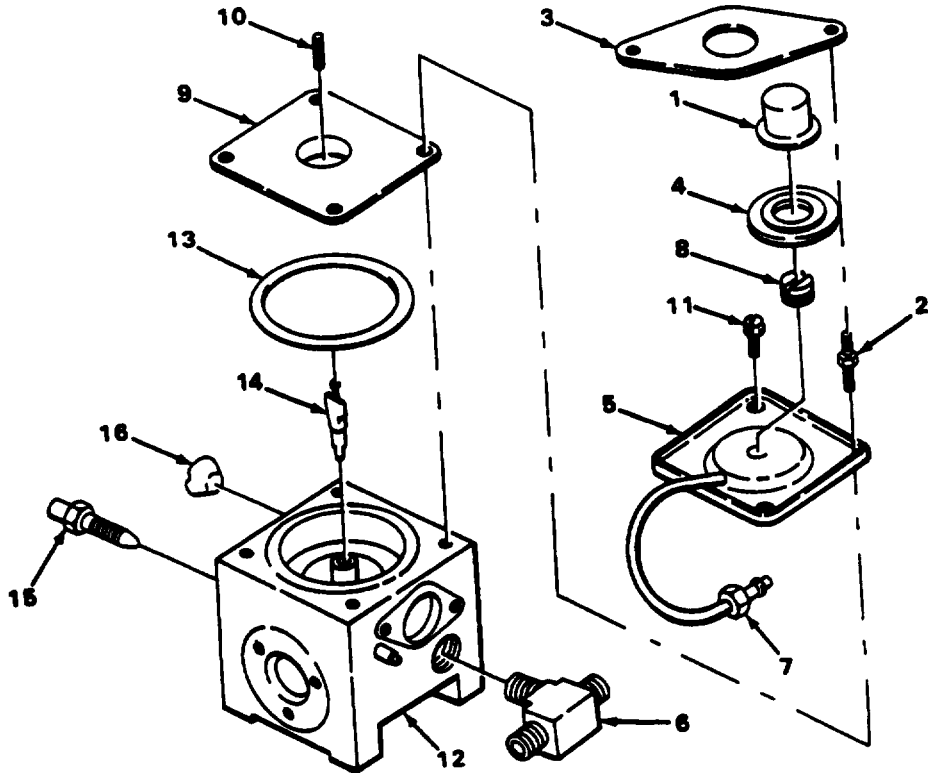

FUEL REGULATOR VALVE - STEWART-WARNER 10560C24, 10560M - Continued

LOCATION	ITEM	ACTION REMARKS
ASSEMBLY		
41. Valve body (1)	Tee (2)	a. Put valve body (1) in vise equipped with jaw caps. b. Screw in and tighten. c. Take valve body out of vise.
42.	Inlet screen (3)	Install.
43.	Bleeder valve (4)	Screw in and tighten,
44.	Valve core (5)	Screw in and tighten.
45.	New packing (5)	Install.
46.	New diaphragm (7)	Install.
47. New diaphragm (7)	Bypass assembly (8)	Install.
48. Bypass assembly (8)	Two screws (9)	Screw in and tighten.
49. New diaphragm (7)	Spring (10)	Install.
50. Bypass assembly (8)	Adjusting screw (11)	Screw in and tighten.
51.	Two studs(12)	Screw in and tighten.
52. Bypass assembly (8) and tee (2)	Nut (13)	Screw in and tighten.
53. Bypass assembly (8)	New gasket (14)	Install.
54. New gasket (14)	Cover (15)	Install.
55. Cover (15) and two studs (12)	Retainer (16)	Install.
56. Retainer (16) and two studs (12)	Two nuts (17)	Screw in and tighten.
57. Valve body (1)	Three new packings (18)	install.
58.	Plate (19)	Install.
59. Plate (20)	New packing (21)	install.
60. Plate (19)	Plate (20) with packing (21)	Install.
61. Plate (20)	Two plates (22)	Install.
62. Two plates (22)	Three screws (23)	Screw in and tighten.

FUEL REGULATOR VALVE - STEWART-WARNER 10560C24, 10560M - Continued

LOCATION	ITEM	ACTION	REMARKS
----------	------	--------	---------

ASSEMBLY - Continued

63. Valve body (1)	Mounting bracket (24)	Install.	
64. Mounting bracket (24) and valve body(1)	Four screws (25)	Screw in and tighten.	

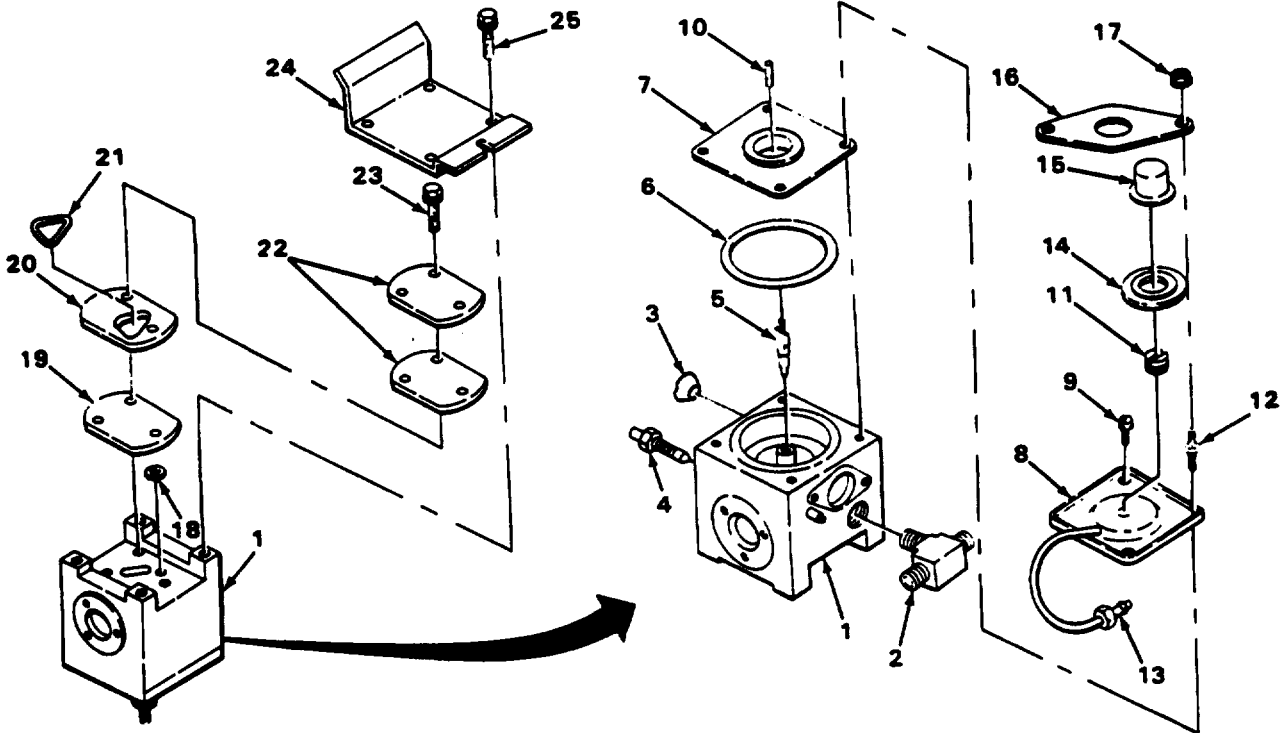

FUEL REGULATOR VALVE - STEWART-WARNER 10560C24, 10560M - Continued

LOCATION	ITEM	ACTION REMARKS
ASSEMBLY - Continued		
65. Valve body (1)	Gasket (2)	Install.
66.	Plunger assembly (3), spring (4), and core assembly (5)	a. Put together. b. Install and hold.
67.	Case (6)	a. install. b. Let go of core assembly (5), and hold case (6).
68. Case (6) and valve body (1)	Three screws (7)	a. Screw in and tighten. b, Let go of case (6)

NOTE

Do not perform steps 69 and 70 unless cover or coil were replaced.

69. Lead (8) and coil (9)	Cover (10)	Install.
70. Lead (8)	Terminal (11)	a. Strip approximately 3/16-inch insulation off lead (8). b. Place terminal (11) in position, and crimp.
71. Case (6)	Cork washer (12), coil (9), and cover (1 O)	Install.
72. Cover (6)	Screw assembly (13)	a. Screw in and tighten. b. Repeat steps 66 thru 72a for other side.

INSTALLATION

73. Heater (14)	Fuel regulator valve (15)	Install.
74. Fuel regulator valve (15) and heater (14)	Three screw assemblies (16)	Screw in and tighten.
75. Overheat switch (17)	Lead (8) and nut assembly (18)	Screw in and tighten.
76. Terminal strip (19)	Restriction solenoid lead (20) and screw assembly (21)	Screw in and tighten.
77, Fuel regulator valve (15)	Two new tie wraps (22)	Install, and cut off excess.

FUEL REGULATOR VALVE - STEWART-WARNER 10560C24, 10560M - Continued

LOCATION	ITEM	ACTION	REMARKS
----------	------	--------	---------

INSTALLATION - Continued

78. Fuel tube (23) and output tee (24)	Nut (25)	a. Screw in and tighten. b. Remove drain pan, and discard fluid.	
--	----------	---	--

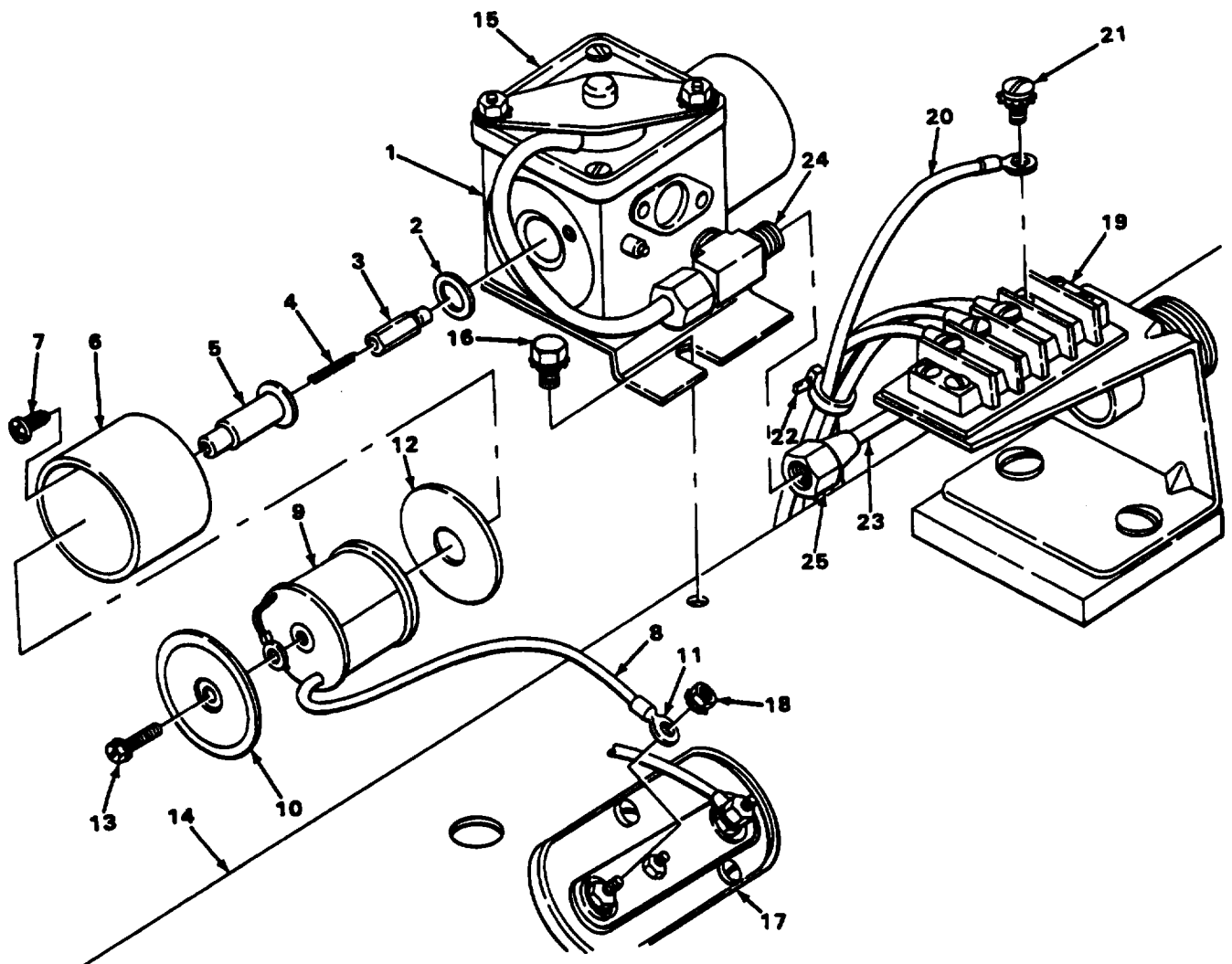

FUEL REGULATOR VALVE - STEWART-WARNER 10560C24, 10560M, 10560G - Continued

LOCATION	ITEM	ACTION	REMARKS
ADJUSTMENT			
NOTE			
You will need either a watch with a second hand or a stopwatch to perform these adjustments. If fuel tube to fuel regulator valve is not connected, omit step 79. If regulator valve retainer and cover are not installed, omit steps 80 and 81.			
79. Tee (1)	Nut (2)	Unscrew and remove.	
80. Retainer (3) and two studs (4)	Two nut assemblies (5)	Unscrew and remove,	
81. Two studs (5)	Retainer (3) with cover (6) and gasket (7)	Remove.	
82. Fuel regulator valve (8)	Tee (1)	a. Put two rubber hoses on tee (1). b. Place end of rubber hoses in drain pan.	

WARNING

The fuels this heater runs on are very explosive. Do not smoke or allow open flame nearby when performing these adjustments. Serious Injury or death to personnel could result if this warning is not observed.

83. Control box (9)	RUN/OFF/START switch (10) and HI/LO switch (11)	a. Disconnect wire lead (12) from 'NO" contact on flame detector to ignition control (13). b. Connect jumper between terminals 5 and 2. c. Place switch (10) in START position and wait a few seconds for fuel flow to stabilize. d. Place switch (11) in HI position. e. Have assistant start timing fuel flow as soon as fuel from rubber hoses is directed into graduated cylinder. f. Place rubber hose in graduated cylinder and start timing. g. Wait 60 seconds and remove hose from graduated cylinder. h. Turn switch (10) off and wipe up any spilled fuel, i. Drain contents of graduated cylinder into drain pan. j. Check table to see if fuel flow is within limits.	
---------------------	--	---	--

FUEL REGULATOR VALVE - STEWART-WARNER10560C24, 10560M-Continued

LOCATION	ITEM	ACTION	REMARKS
----------	------	--------	---------

ADJUSTMENT - Continued

FUEL	cu. in./cc PER MINUTE
DF1, DFA, JP8	2.1 to 2.5/44 to 48
DF2	2.2 to 1.6/40 to 45

84. Fuel regulator valve (8)

Adjustment screw (12)

If fuel flow is not within limits shown in the table, adjust.

Turn clockwise to increase fuel flow and counterclockwise to decrease fuel flow. Repeat step 81 until fuel flow is within limits shown in the table.

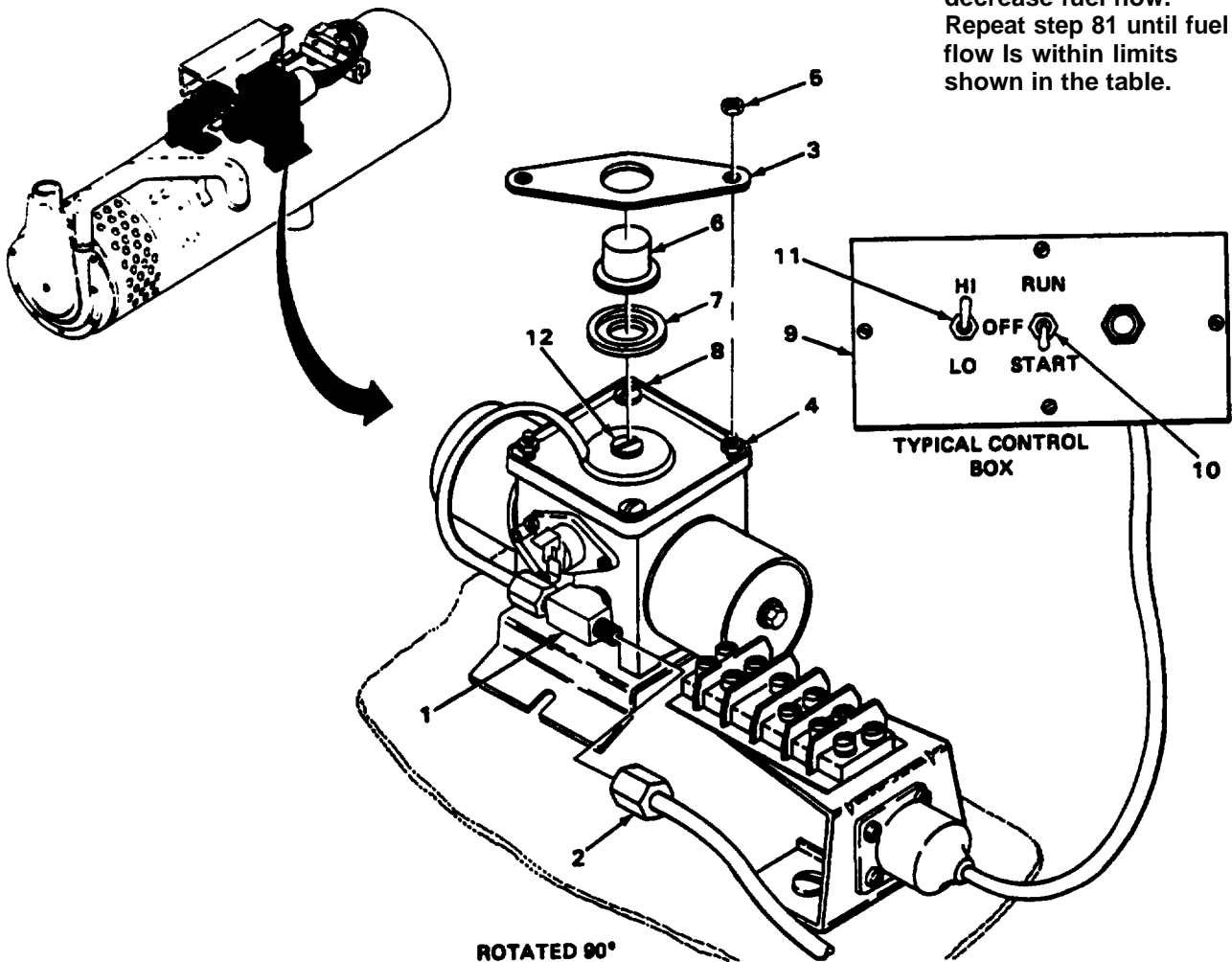

FUEL REGULATOR VALVE - STEWART-WARNER 10560C24, 10560M - Continued

LOCATION	ITEM	ACTION	REMARKS
----------	------	--------	---------

ADJUSTMENT - Continued

- | | | |
|---------------------|--|---|
| 85. Control box (1) | RUN/OFF/START switch (2)
and HI/LO switch (3) | <ul style="list-style-type: none"> a. Place end of rubber hose in drain pan. b. Place switch (3) in LO position.
Wait a few seconds for fuel flow to stabilize. c. Have assistant start timing fuel flow as soon as fuel from rubber hoses is directed into graduated cylinder. d. Wait 60 seconds, and turn switch (2) to OFF position.
Wipe up any excess fuel that may have been spilled. e. Drain contents of graduated cylinder into drain pan. f. Check table to see if fuel flow is within limits. |
|---------------------|--|---|

FUEL	cu. in./cc PER MINUTE
DF1 , DFA, JP8	1.0 to 1.4/23 to 27
DF2	1,0 to 1.4/21 to 24

If fuel flow is not within limits, disassemble and inspect fuel regulator valve (page 2-57).

If fuel regulator valve has just been assembled, replace adjustment spring and repeat adjustment procedure.

If fuel flow is still not within limits, replace fuel regulator valve (page 3-74).

- g. Remove rubber hose.

FUEL REGULATOR VALVE - STEWART-WARNER 10560C24, 10560M - Continued

LOCATION	ITEM	ACTION	REMARKS
ADJUSTMENT - Continued			
85. Control box (1) - Continued			h. Discard fuel in drain pan. i. Connect wire lead (4) to 'NO' on flame detector(5).
86. Two studs (4)	Retainer (5) with cover (6) and gasket (7)	Install.	
87. Retainer (5) and two studs (4)	Two nut assemblies (8)	Screw on and tighten.	
88. Tee (9)	Nut (10)	Screw on and tighten.	

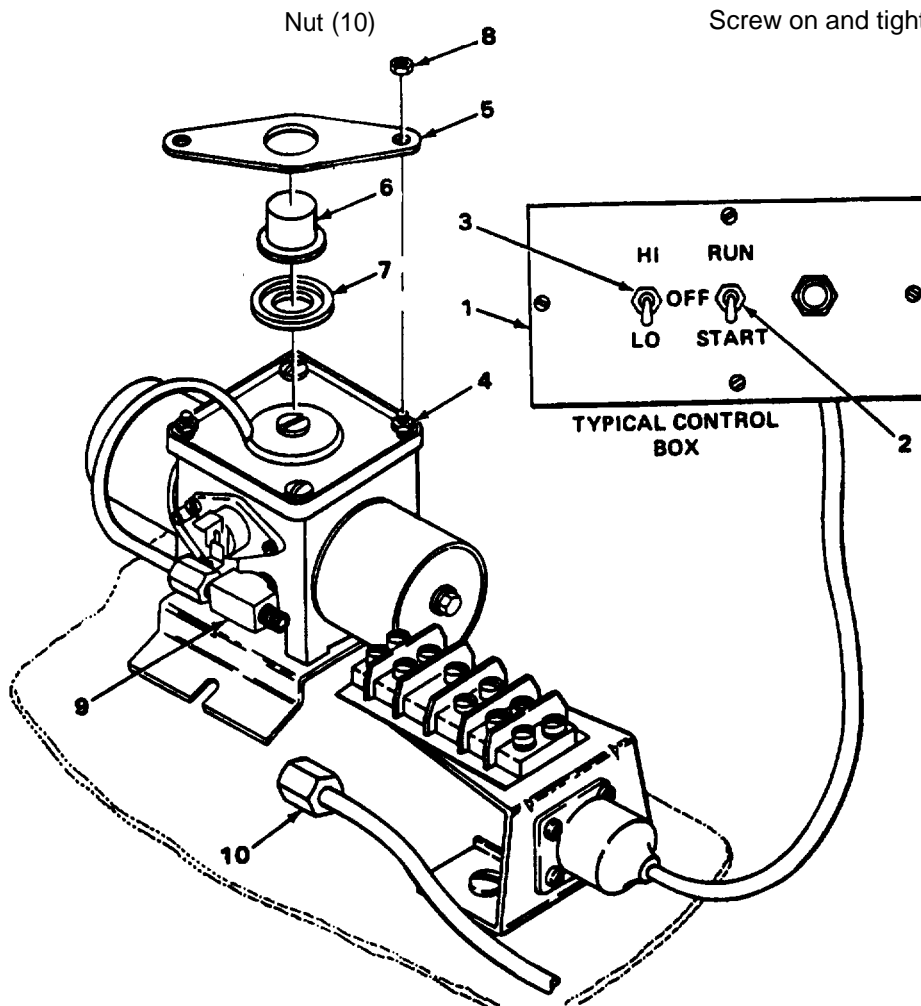

NOTE
FOLLOW-ON MAINTENANCE:

1. Install valve thermostat (page 2-55).
2. Install ignition control (page 2-47).

TASK ENDS HERE

PULSED FUEL METERING VALVE - STEWART-WARNER 10560M24B1, 10560G

This task covers:

- | | |
|------------------------|-----------------|
| a. Removal | d. Assembly |
| b. Disassembly | e. Installation |
| c. Cleaning/Inspection | f. Adjustment |

INITIAL SETUP

<p>Tools</p> <p>Tool Kit, Mechanics Gen (Item 1, Appendix B)</p> <p>Materials/Parts</p> <p>Cylinder, graduated, 100cc capacity Hose, plastic, clear, 3/16-inch ID, 50-inch Hose, rubber, 12-inch Humiseal (Item 4, Appendix C) Measuring stick, 36-inch (two required) Pan, drain Parts Kit, valve Rags, wiping (Item 5, Appendix C) Screen, inlet Sealant, silicon (Item 6, Appendix C) Solvent, drycleaning (Item 8, Appendix C) Tags, marking (Item 9, Appendix C) Tape, insulating, electrical (Item 10, Appendix C) Tie wraps (Item 11, Appendix C)</p>	<p>Personnel Required</p> <p>Two</p> <p>Equipment Condition</p> <p>Ignition control removed (page 2-47) Valve thermostat removed (page 2-55)</p>
--	--

LOCATION	ITEM	ACTION	REMARKS
----------	------	--------	---------

REMOVAL

NOTE

Tag all wires and terminals to aid during installation (page 2-3).

1. Elbow (1)	Nut (2)	Unscrew.
2. Pulsed fuel metering valve (3)	Two tie wraps (4)	Remove.
3. Terminal strip (5)	Lead (6) and screw assembly (7)	Unscrew and remove.
4. Overheat switch (8)	Nut assembly (9) and lead (10)	Unscrew and remove.
5. Pulsed fuel metering valve (3)	Three screw assemblies (11)	Unscrew and remove.
6. Heater (12)	Pulsed fuel metering valve (3)	Remove.

PULSED FUEL METERING VALVE - STEWART-WARNER 10560M24B1, 10560G - Continued

LOCATION	ITEM	ACTION REMARKS
----------	------	-------------------

REMOVAL - Continued

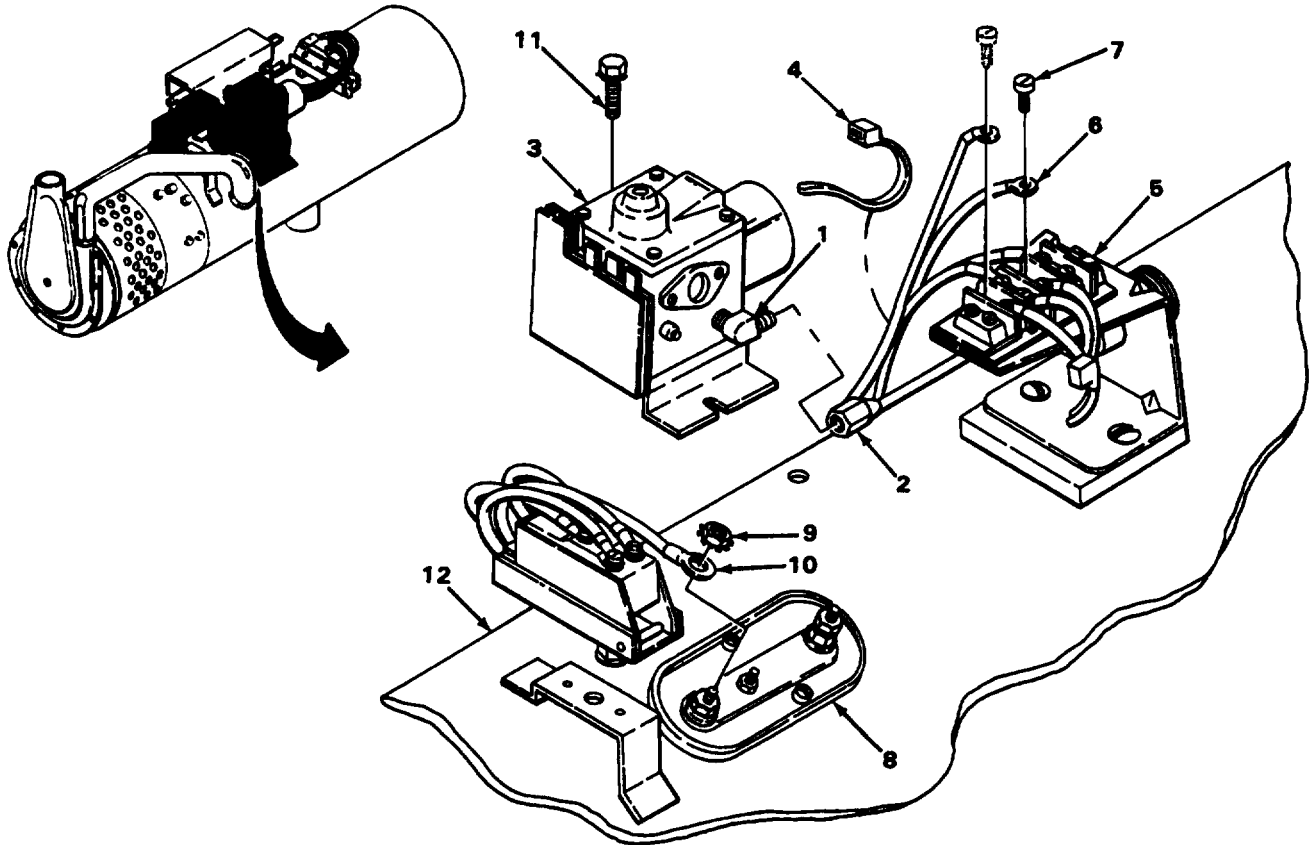

PULSED FUEL METERING VALVE - STEWART-WARNER 10560M24B1, 10560G - Continued

LOCATION	ITEM	ACTION REMARKS
DISASSEMBLY		
7. Heating element (1)	Screw (2)	Unscrew and remove.
8. Valve body (3)	Heating element (1)	Remove.
9. Pulse generator(4)	Solenoid lead (5)	Pull off terminal.
10. Cover (6)	Screw assembly (7)	Unscrew and remove.
11. Case (8)	Cover (6), coil (9), and cork spacer (10)	Remove.
12. Valve body (3)	Three screws (11)	Unscrew and remove.
13. Case (8)	Core assembly (12), spring (13), and plunger assembly (14)	a. Remove. b. Discard plunger (14).
14.	Gasket (15)	a. Remove. b. Discard.
15. Pulse generator (4)	Lead (16) and lead (17)	Remove.
16. Two studs (18)	Two nuts (19), two washers (20), shield (21), and pulse generator (4)	a. Unscrew and remove. b. Separate.
17. Pulse generator (4)	Two insulating washers (22)	Remove.
18. Valve body (3)	Two studs (18)	Unscrew and remove.
19.	Sealing plate (23) and packing (24)	a. Remove. b. Discard packing (24).

PULSED FUEL METERING VALVE - STEWART-WARNER 10560M24B1, 10560G - Continued

LOCATION	ITEM	ACTION	REMARKS
----------	------	--------	---------

DISASSEMBLY - Continued

CAUTION

Do not pry out inlet screen with sharp object. Damage to valve may result.

20.	Inlet screen (25)	a. Remove. b. Discard.	
21.	Valve body (3)	Four screws (26) and diaphragm cap (27)	Unscrew and remove.
22.	Spring cap (28), spring (29), and diaphragm assembly (30)	a. Remove. b. Discard diaphragm (30) and packing (31).	
23.	Two packings (31) and fuel metering orifice (32)	a. Turn valve body (3) upside down. b. Tap valve body (3) against palm of hand until packings (31) and orifice (32) fall out. c. Discard packing (31).	

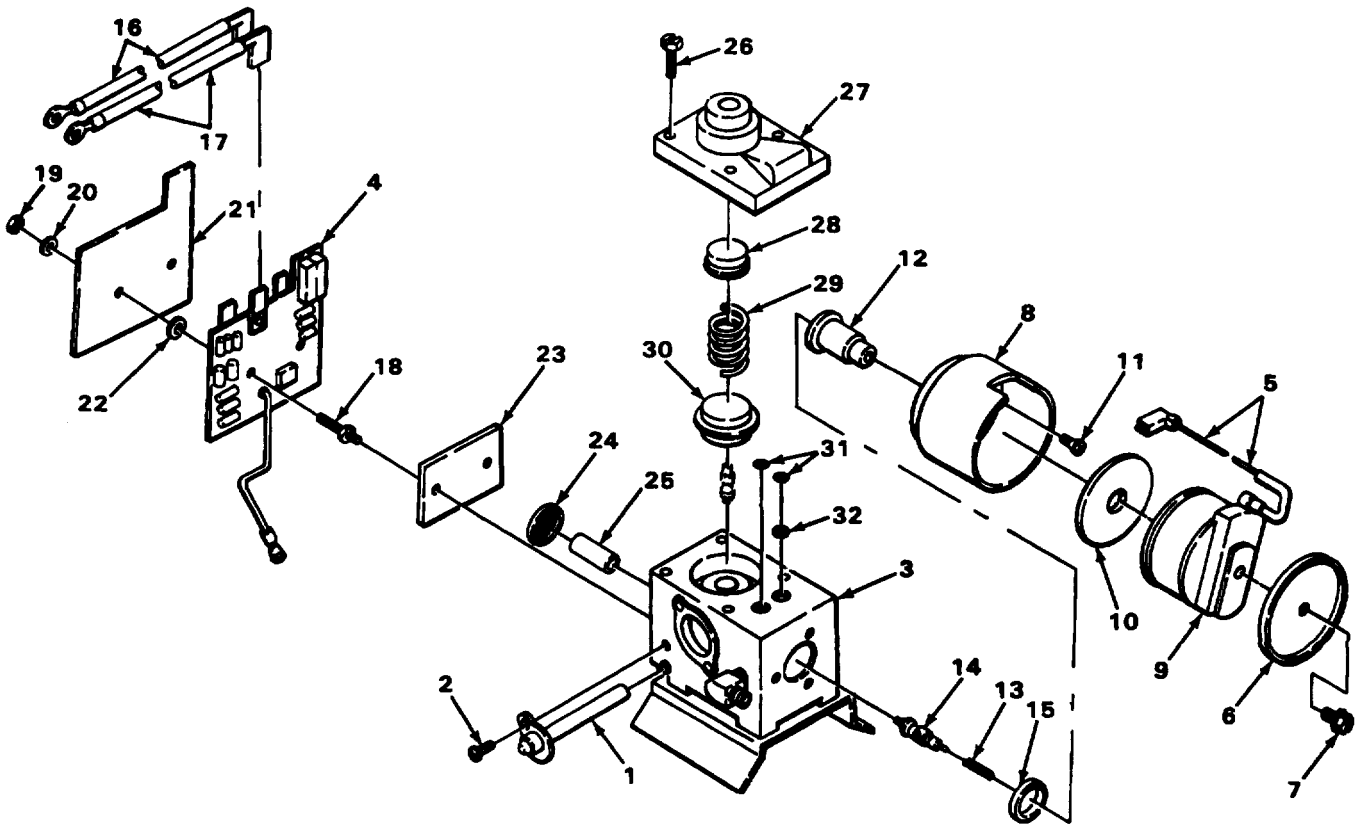

PULSED FUEL METERING VALVE - STEWART-WARNER 10560M24B1, 10560G - Continued

LOCATION	ITEM	ACTION REMARKS
DISASSEMBLY - Continued		
24. Valve body (1)	Valve core (2)	a. Unscrew and remove. b. Discard.
25.	Bleeder valve (3)	Unscrew and remove.
26.	Four screws (4) and bracket (5)	Unscrew and remove.
27.	Elbow (6)	a. Place valve body (1) in vise equipped with jaw caps. b. Unscrew and remove. c. Take valve body(1) out of vise.
CLEANING/inspection		
28. Valve body (1)	Nonmetal parts	a. Wipe clean with dry rags. b. Look for signs of damage. Replace if damaged.
29.	Pulse generator (7)	a. Wipe clean with dry rags. b. Look for cracks and chips in coating. The pulse generator has a moisture resistant coating. Apply humi-seal to cracks and chips in coating. Pulse generator must give off heat during operation, and should not be recoated more than one time.

WARNING

Drycleaning solvent PD-680 is both toxic and flammable. Wear protective goggles and gloves, and use only in well-ventilated area. Avoid contact with skin, eyes, and clothes, and don't breathe vapors. Do not use near open flame or excessive heat. The flashpoint is 100°F to 138°F (38°C to 59°C). If you become dizzy while using dry cleaning solvent, get fresh air immediately, and get medical aid. If contact with eyes is made, wash your eyes with water, and get medical aid immediately.

PULSED FUEL METERING VALVE - STEWART-WARNER 10560M24B1, 10560G - Continued

LOCATION	ITEM	ACTION	REMARKS
DISASSEMBLY - Continued			
30.	Valve body (1) and fuel metering orifice (8)	a. Soak clean in solvent. b. Allow to air dry. c. Look for cracks, distortion, corrosion, or other damage. Replace if damaged.	
31.	All other metal parts	a. Wipe clean with solvent-dampened rags. b. Allow to air dry. c. Look for cracks, distortion, corrosion, or other damage. Replace any damaged parts.	

ASSEMBLY

32.	Elbow (6)	a. Put valve body (1) in vise equipped with jaw caps. b. Screw in and tighten. c. Take valve body (1) out of vise.	
33.	Four screws (4) and bracket (5)	Screw in and tighten.	
34.	Bleeder valve (3)	Screw in and tighten.	
35.	New valve core (2)	Screw in and tighten.	
36.	Fuel metering orifice (8) and two new packings (9)	Install.	

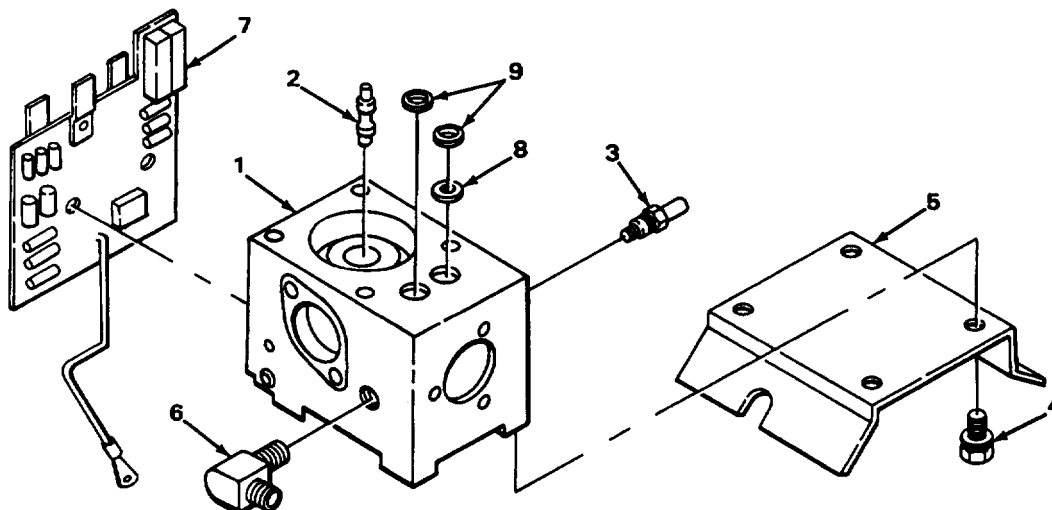

PULSED FUEL METERING VALVE - STEWART-WARNER 10560M24B1, 10560G - Continued

LOCATION	ITEM	ACTION REMARKS
----------	------	-------------------

ASSEMBLY - Continued

37. Valve body (1)	New diaphragm assembly (2), regulating spring (3), spring cap (4), and diaphragm cap (5)	install.
38. Diaphragm cap (5)	Four screws (6)	Screw in and tighten.

CAUTION

Do not use sharp objects to install inlet screen. Damage to valve body may result.

39. Valve body (1)	New inlet screen (7)	Install.
40.	New packing (8)	Install.
41.	Seal plate (9) and two studs (10)	a. install. b. Screw in and tighten.
42. Pulse generator (11)	Two insulating washers (12)	Install.
43. Two studs (10)	Pulse generator (11), with two insulating washers (12), and shield (13)	Install.
44.	Two washers (14) and nuts (15)	Screw in and tighten.
45. Pulse generator (11)	Lead (16)	Install.
48.	Lead (17)	Install.
47. Plunger assembly (19)	Spring (19)	Install.
48. Core assembly (20)	New plunger assembly (18)	Install.
49. Valve body (1)	New gasket (21), core assembly (20), and case (22)	Install. Notch in case must go on top.
50. Case (22)	Three screws (23)	Screw in and tighten.
51.	Cork spacer (24), coil (25), and cover (26)	Install. Coil lead must go on bottom.
52. Cover (26)	Screw (27)	Screw in and tighten.

PULSED FUEL METERING VALVE - STEWART-WARNER 10560M24B1, 10560G - Continued

LOCATION	ITEM	ACTION	REMARKS
----------	------	--------	---------

ASSEMBLY - Continued

53. Pulse generator (11)	Solenoid lead (28)	Install.	
54. Valve body (1)	Heating element (29)	Install.	
55. Heating element (29)	Screw (30)	Screw in and tighten.	

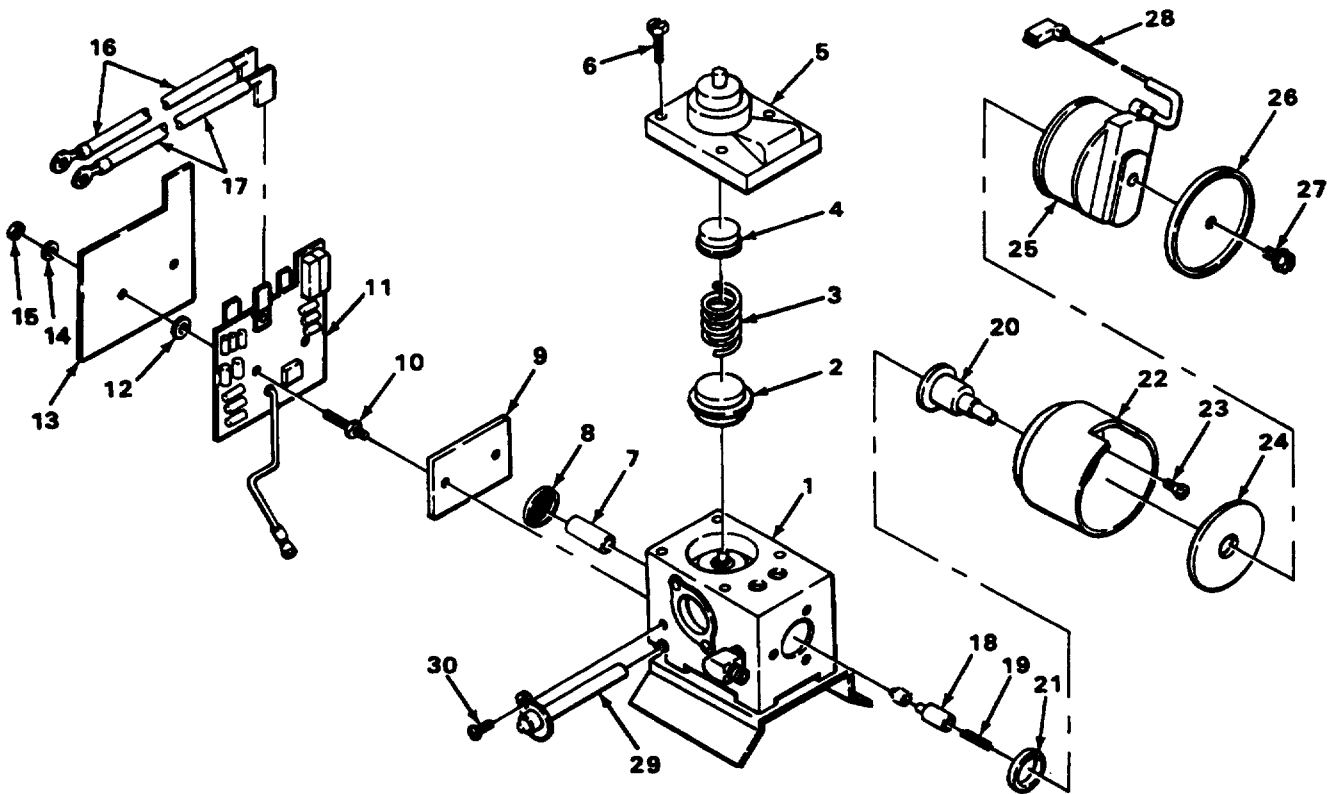

PULSED FUEL METERING VALVE - STEWART-WARNER 10560M24B1, 10560G - Continued

LOCATION	ITEM	ACTION	REMARKS
INSTALLATION			
56. Heating housing (1)	Pulsed fuel metering valve (2)	Install.	
57.	Three screw assemblies (3)	Screw in and tighten.	
58. Overheat switch (4)	Lead (5) and nut (6)	Screw on and tighten.	
59. Terminal strip (7)	Lead (8) and screw assembly (9)	Screw on and tighten.	
60. Pulsed fuel metering valve (2)	Two new tie wraps (10)	Install, and cut off excess.	

ADJUSTMENT

NOTE

If pulsed fuel metering valve adjustment is necessary, omit step 61.

61. Elbow (11)	Nut (12)	Screw in and tighten.	
----------------	----------	-----------------------	--

NOTE

When performing the pulsed fuel metering valve adjustment, the 24 Vdc current must be filtered to 5 percent ripple maximum. You will need either a watch with a second hand or a stopwatch to perform these adjustments. If fuel tube to fuel regulator valve is not connected, omit step 62.

62. Heater housing (1)	Valve thermostat	Install (page 2-55).	
63. Heater housing (1)	Igniter control	Install (page 2-49).	

NOTE

Heater must be mounted and operating in the LO mode on the heater test stand before adjustment can be performed.

NOTE

With the heater operating in the LO heat mode, compare fuel flow in heater test stand sight glass to heater specifications. If fuel flow is within specifications, then operate heater in the HI mode. Compare fuel flow in heater test stand sight glass to heater specifications (page 3-85). If fuel flow is within specifications for LO and HI mode, no further adjustment is necessary.

WARNING

The fuels this heater runs on are flammable. Do not smoke or allow open flame nearby when performing these adjustments. Serious injury or death to personnel could result if this warning is not observed.

NOTE

Check regulator adjustment internal hex screw for evidence of tampering. Scrape off sealant. Set regulator adjusting internal hex screw between FLUSH and 2 turns below the top.

PULSED FUEL METERING VALVE - STEWART-WARNER 10560M24B1, 10560G - Continued

LOCATION	ITEM	ACTION REMARKS
----------	------	-------------------

ADJUSTMENT - Continued

64. Pulsed fuel metering valve (1)	LO adjustment screw(16)	Wait a few seconds for fuel flow to stabilize. Adjust fuel flow for LO heat until within specifications. Turn clockwise to decrease fuel flow, and counterclockwise to increase fuel flow.
------------------------------------	-------------------------	--

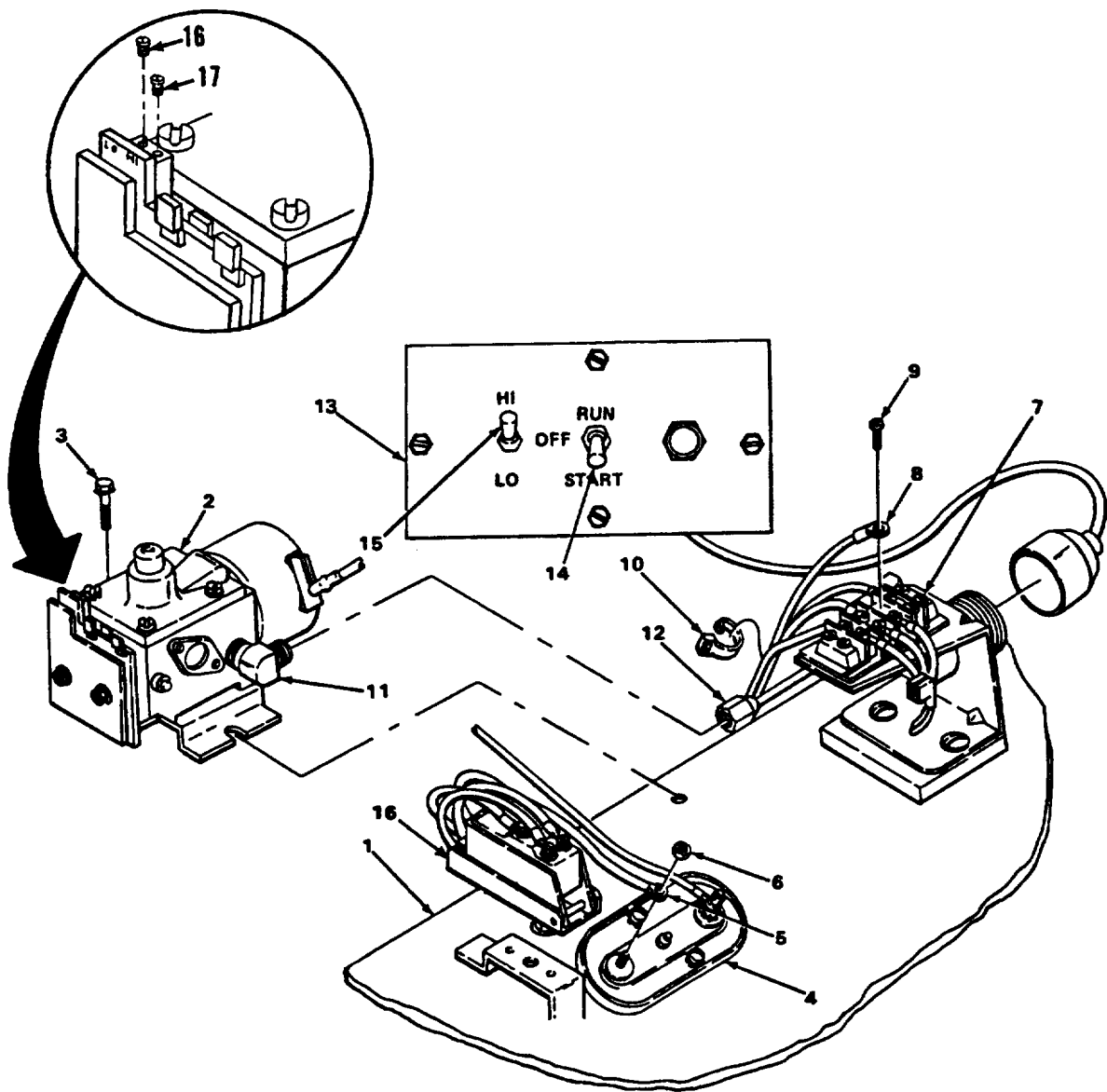

PULSED FUEL METERING VALVE - STEWART-WARNER 10560M24B1, 10560G - Continued

LOCATION	ITEM	ACTION	REMARKS
----------	------	--------	---------

ADJUSTMENT - Continued

NOTE

Adjust LO heat first. Flows interact if HI heat is adjusted first. A HI fuel flow adjustment can affect the LO fuel flow adjustment, but the LO fuel flow adjustment will not affect the HI fuel flow adjustment.

65. Pulsed fuel metering valve (1)	HI adjustment screw(17)	a. Wait a few seconds for fuel flow to stabilize. Adjust fuel flow for HI heat until within specifications. b. If fuel flow is within specification for LO and HI, no further adjustment is needed.	
------------------------------------	-------------------------	--	--

NOTE

Reseal all adjusting screws using insulating electrical varnish upon completion of final adjustment.

- c. If fuel flow will not adjust to within specifications, disassemble pulsed fuel metering valve (page 2-57), and inspect. Clean filter as required, and replace O-ring, If filter is clean, rebuild valve (page 2-55).
- d. If fuel flow still will not adjust to specifications, replace pulsed fuel metering valve (page 2-57).

NOTE

FOLLOW-ON MAINTENANCE:

1. Install valve thermostat (page 2-55).
2. Install ignition control (page 2-47).

TASK ENDS HERE

BLOWER ASSEMBLY - STEWART-WARNER 10560C24, 10560G

This task covers:

- | | |
|----------------|-----------------|
| a. Removal | c. Assembly |
| b. Disassembly | d. Installation |
-

INITIAL SETUP

Tools	Personnel Required
Tool Kit, Mechanics Gen (Item 1, Appendix B)	63G
Materials/Parts	Equipment Condition
Tags, marking (Item 9, Appendix C)	Guard removed (page 2-42)

LOCATION	ITEM	ACTION REMARKS
----------	------	-------------------

REMOVAL

NOTE

Tag all wires and terminals to aid during installation (page 2-3).

1. Terminal strip (1)	Screw assembly (2) and two leads (3)	Unscrew and remove.
2. Ignition control (4)	Lead (5)	Remove.
3. Blower assembly (6) and heater (7)	Four screw assemblies (8)	a. Prior to removal, mark position of heater (7) and blower assembly (6). b. Unscrew and remove.
4. Heater (7)	Blower assembly (6)	Remove.
5. Grommet (9)	Lead (10) and lead (11)	Pull through one at a time.

BLOWER ASSEMBLY - STEWART-WARNER 10560C24, 10560G - Continued

LOCATION	ITEM	ACTION	REMARKS
----------	------	--------	---------

REMOVAL - Continued

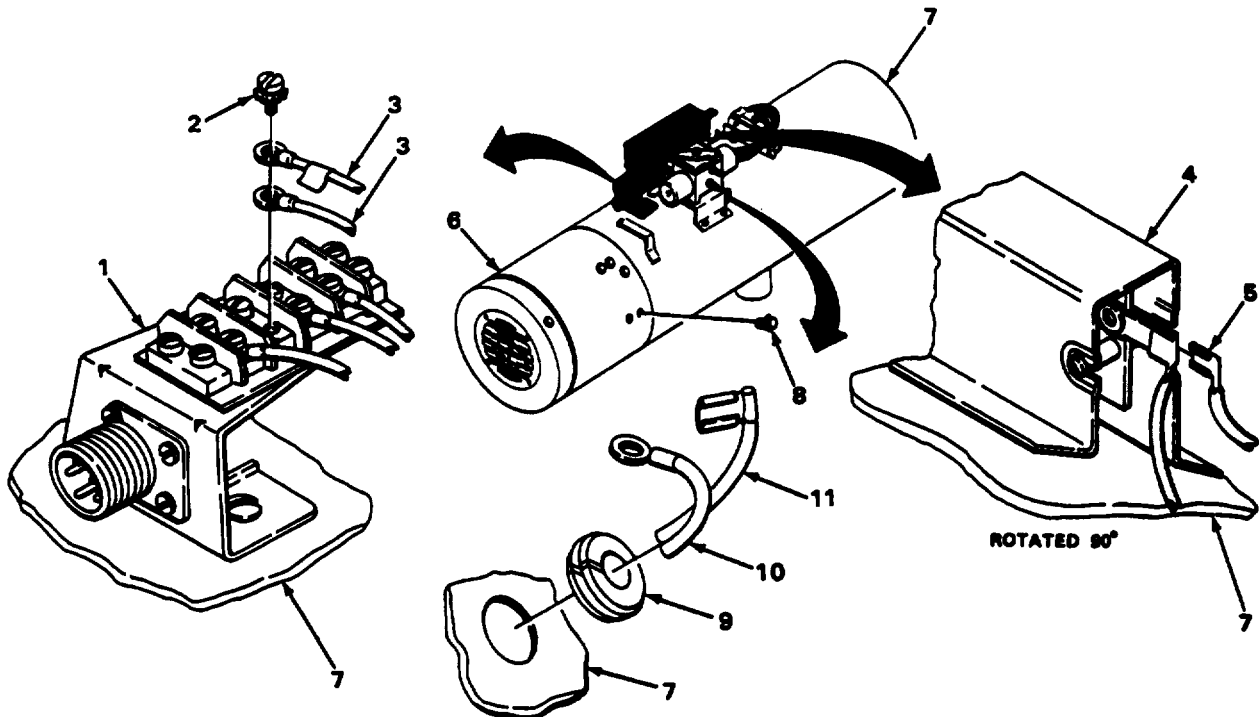

DISASSEMBLY

6. Blower housing (1) and three mounting brackets (2)	Voltage limiter	Remove (page 3-99).
7.	Diode mounting assembly	Remove (page 3-120).
8.	Six screw assemblies (3)	a. Mark position of housing (1) and brackets (2). b. Unscrew and remove.
9. Blower housing (1)	Motor (4)	Remove.
10. Combustion blower wheel (5)	Setscrew (6)	Unscrew part way.
11. Motor (4)	Combustion blower wheel (5)	Remove.
12. Motor (4) and blower cover (7)	Nut assembly (8)	Unscrew and remove.

BLOWER ASSEMBLY - STEWART-WARNER 10560C24, 10560G - Continued

LOCATION	ITEM	ACTION REMARKS
DISASSEMBLY - Continued		
13. Motor (4)	Blower cover (7)	Remove.
14. Ventilation blower wheel (9)	Setscrew (10)	Unscrew part way.
15. Motor (4)	Ventilation blower wheel (9)	Remove.
16. Motor (4) and three mounting brackets (2)	Three screws (11)	a. Mark position of motor (4) and brackets (2). b. Unscrew and remove.
17. Motor (4)	Three mounting brackets (2)	Remove.

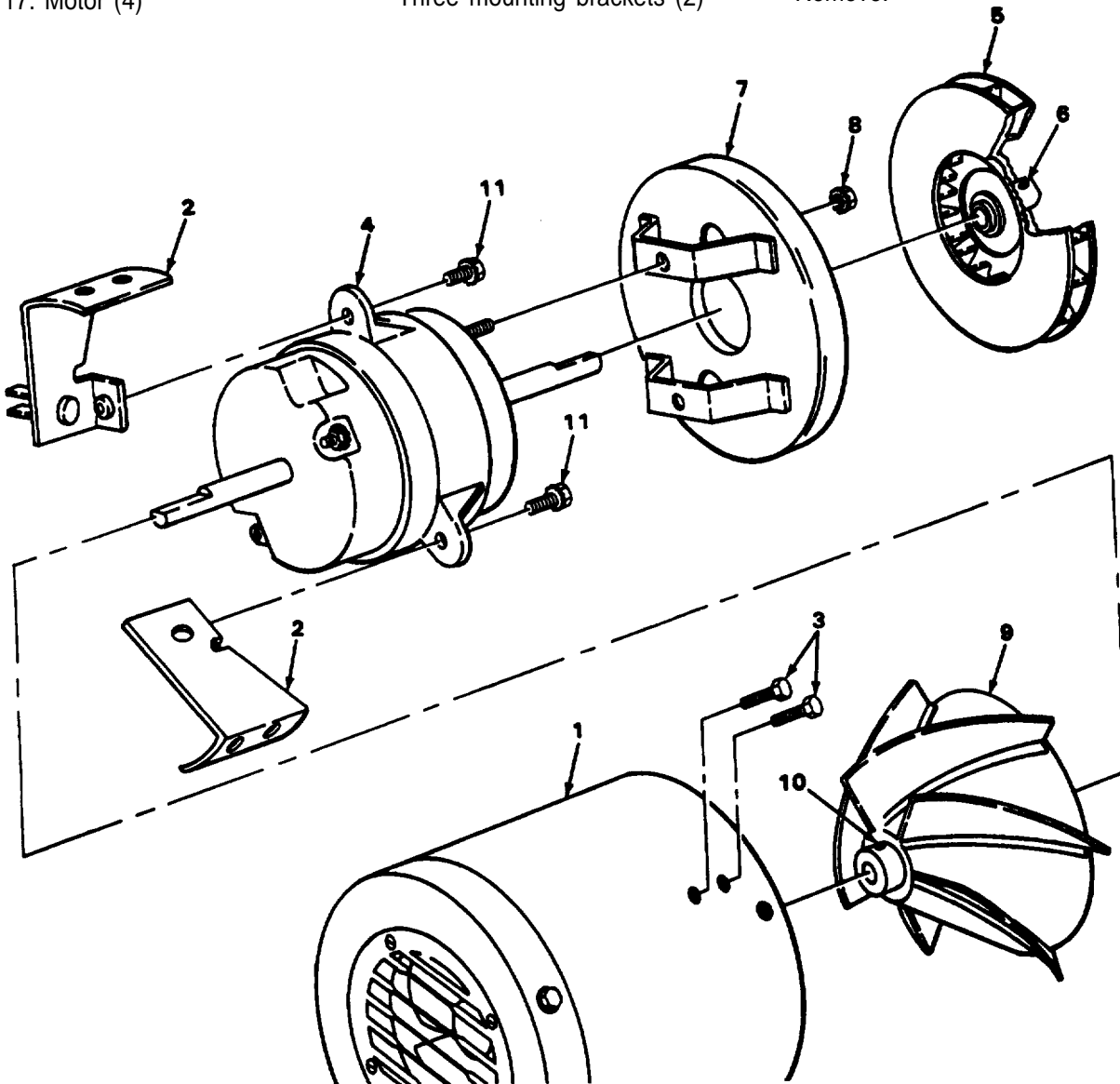

BLOWER ASSEMBLY - STEWART-WARNER 10560C24, 10560G - Continued

LOCATION	ITEM	ACTION REMARKS
ASSEMBLY		
18. Motor (1)	Three mounting brackets (2)	Install, noting position marks.
19. Motor (1) and three mounting brackets (2)	Three screw assemblies (3)	Screw In and tighten.
20. Motor (1)	Ventilation blower wheel (4)	Slide on with setscrew (5) in line with flat side of shaft.
21. Ventilation blower wheel (4)	Setscrew (5)	Screw in and tighten,
22. Motor (1)	Blower cover (6)	install.
23. Motor (1) and blower cover (6)	Nut assembly (7)	Screw in and tighten.
24. Motor (1)	Combustion blower wheel (8)	Slide on with setscrew (9) in line with fiat side of shaft.
25. Combustion blower wheel (8)	Setscrew (9)	Screw in and tighten.
26. Blower housing (10)	Motor (1)	install, noting positions marked.
27. Blower housing (10) and three mounting brackets (2)	Six screw assemblies (11)	Screw In and tighten,
28.	Diode mounting assembly	install (page 3-120).
29.	Voltage regulator	install (page 3-1 14),

BLOWER ASSEMBLY - STEWART-WARNER 10560C24, 10560G - Continued

LOCATION	ITEM	ACTION	REMARKS
----------	------	--------	---------

ASSEMBLY - Continued

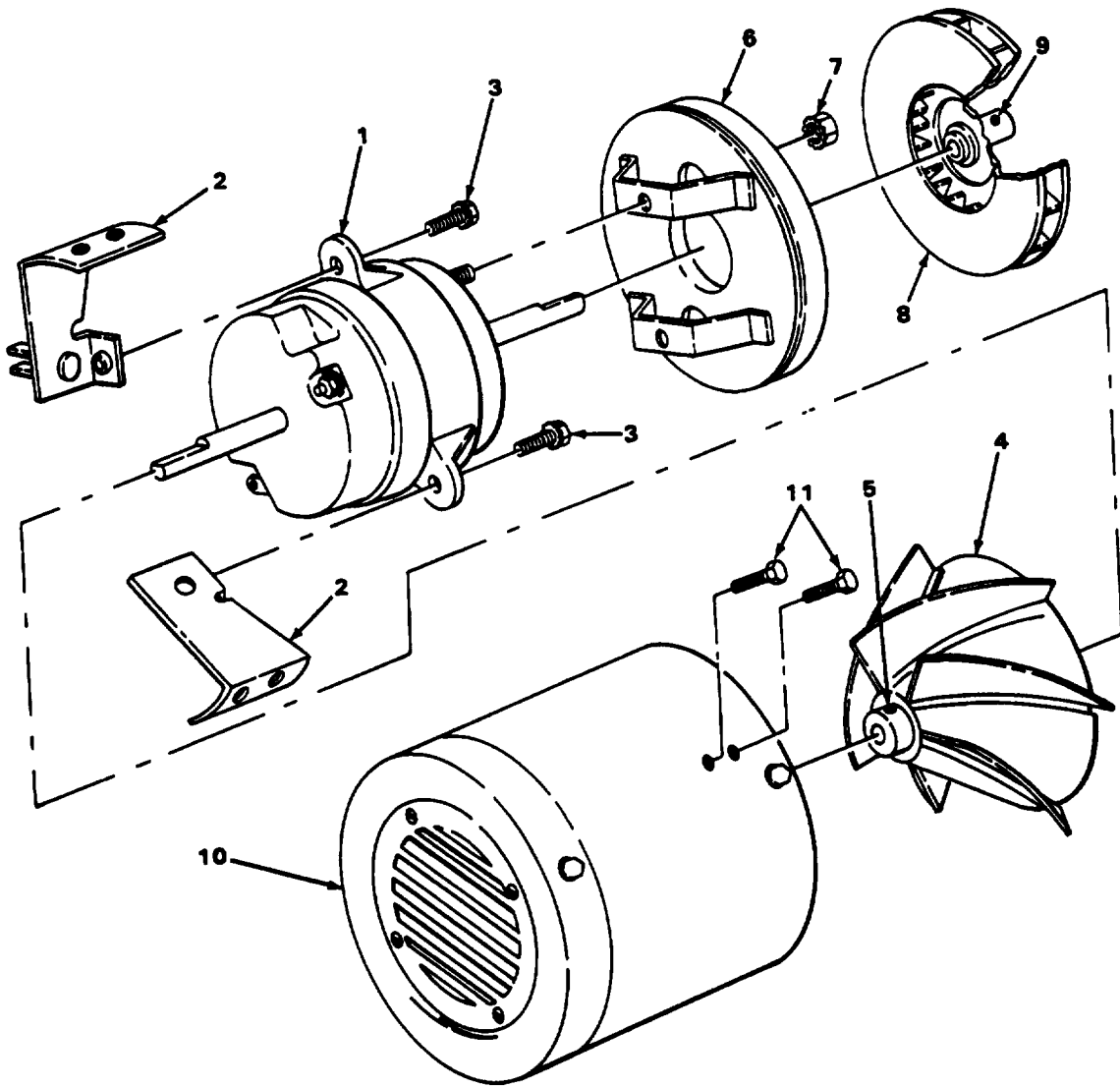

BLOWER ASSEMBLY - STEWART-WARNER 10560C24, 10560G - Continued

LOCATION	ITEM	ACTION	REMARKS
INSTALLATION			
30. Grommet (1)	Lead (2) and lead (3)	Push through from inside one at a time.	
31. Heater (4)	Blower assembly (5)	a. Install, noting position marks. b. Push together.	
32. Blower assembly (5) and heater (4)	Four screw assemblies (6)	Screw in and tighten.	
33. Ignition control (7)	Lead (3)	Install.	
34. Terminal strip (8)	Two leads (9) and screw assemblies (10)	Screw in and tighten,	

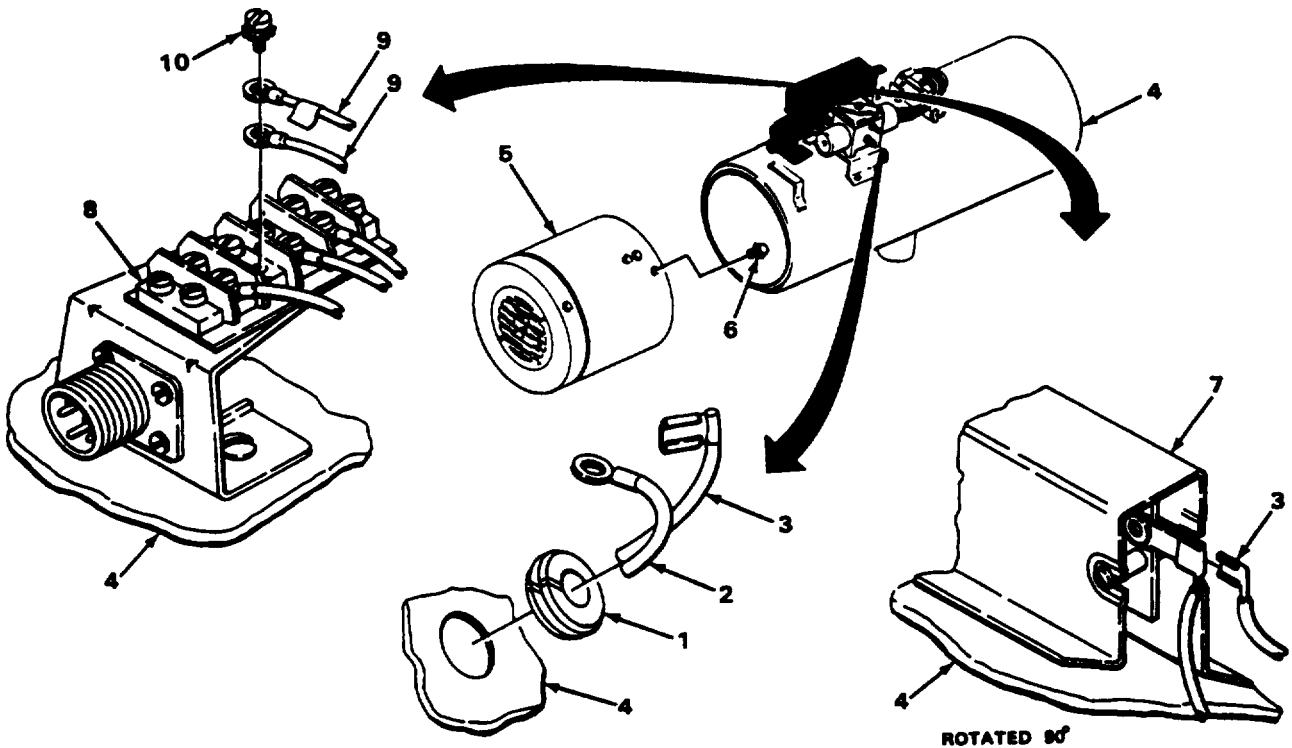

NOTE
FOLLOW-ON MAINTENANCE: Install guard (2-42).

TASK ENDS HERE

BLOWER ASSEMBLY - STEWART-WARNER 10560M, 10560M24B1

This task covers:

- | | |
|----------------|-----------------|
| a. Removal | c. Assembly |
| b. Disassembly | d. Installation |

INITIAL SETUP

Tools	Personnel Required
Tool Kit, Mechanics Gen (Item 1, Appendix B) Key, socket-head screw, 3/32-inch (Item 2, Appendix B)	63G
Materials/Parts	Equipment Condition
Tags, marking (Item 9, Appendix C)	Guard removed (page 2-42)

LOCATION	ITEM	ACTION	REMARKS
----------	------	--------	---------

REMOVAL

NOTE

Tag all wires and terminals to aid during installation (page 2-3).

1. Terminal strip (1)	Screw assembly (2) and two leads (3)	Unscrew and remove.
2. Ignition control (4)	Lead (5)	Remove.
3. Blower assembly (6)	Hose clamp (7)	Unscrew part way.
4.	Hose (8)	Remove.
5.	Four screw assemblies (9)	a. Mark position of blower assembly (6) to heater (10). b. Unscrew and remove.
6. Heater (10)	Blower assembly (6)	Remove.
7. Grommet (11)	Leads (3) and (5)	Pull through.
8. Heater (10)	Grommet (11)	Remove.

DISASSEMBLY

9. Inlet duct (12)	Screw assembly (13) and inlet adapter (14)	Unscrew and remove.
10. Adapter (14)	Grommet (15)	Remove.
11. Blower housing (16)	Nine screw assemblies (17), inlet duct (12), and combustion blower gasket (18)	a. Unscrew and remove. b. Remove and discard gasket (18).
12. Combustion blower wheel (19)	Setscrew (20)	Unscrew part way.

BLOWER ASSEMBLY - STEWART-WARNER 10560M, 10560M24B1 - Continued

LOCATION	ITEM	ACTION	REMARKS
----------	------	--------	---------

DISASSEMBLY - Continued

13. Motor assembly (21)	Combustion blower wheel (19)	Remove.	
-------------------------	------------------------------	---------	--

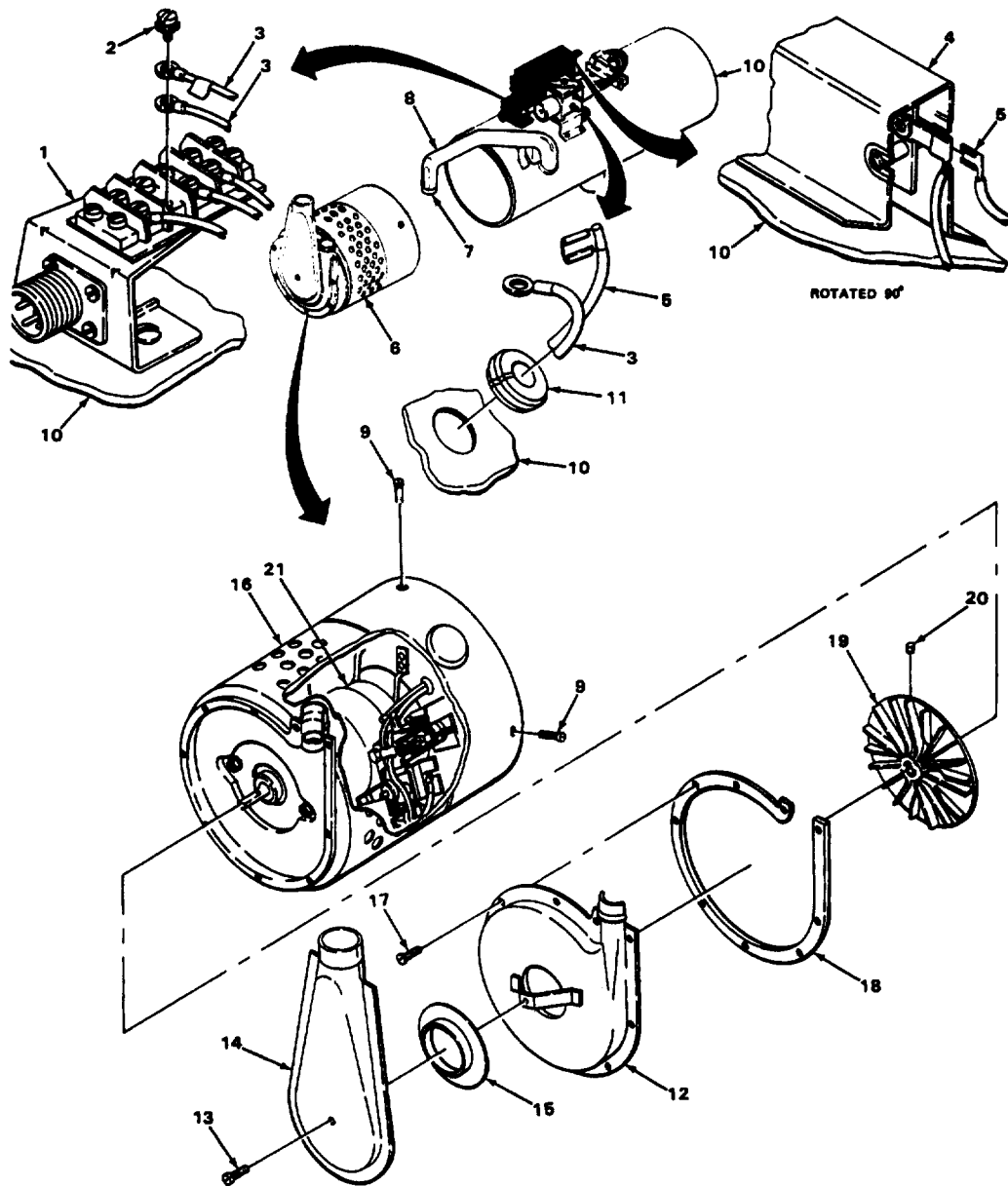

BLOWER ASSEMBLY - STEWART-WARNER 1056OM, 1056OM24B1 - Continued

LOCATION	ITEM	ACTION REMARKS
DISASSEMBLY - Continued		
14. Blower housing (1) and motor subassembly (2)	Two nut assemblies (3)	Unscrew and remove.
15.	Two screw assemblies (4)	a. Mark position of blower housing (1) to motor sub-assembly (2). b. Unscrew and remove.
16. Blower housing (1)	Motor subassembly (2)	Remove.
17. Motor subassembly (2)	Two gaskets (5), washers (6), and one gasket (7)	Remove.
18. Blower housing (1)	Plug (8)	Pry out.
19. Diode mounting assembly (9)	Screw assembly (10) and lead (11)	a. Unscrew and remove. b. Pull lead (11) through diode mounting assembly (9).
20. Ventilation blower wheel (12)	Setscrew (13)	a. Rotate wheel (12) so setscrew (13) is in line with hole in air housing (14). b. Unscrew and remove partway.
21. Motor (15)	Ventilation blower wheel (12)	Remove.
22. Air housing (14)	Four screws (16)	a. Mark position of motor (15) to air housing (14). b. Unscrew and remove.
23.	Motor (15)	Remove.
24. Air housing (14) and grommet (17)	Two leads (18)	Pull through and remove.
25. Air housing (14)	Grommet (17)	Remove.

BLOWER ASSEMBLY - STEWART-WARNER 10560M, 10550M24B1 - Continued

LOCATION	ITEM	ACTION	REMARKS
----------	------	--------	---------

DISASSEMBLY - Continued

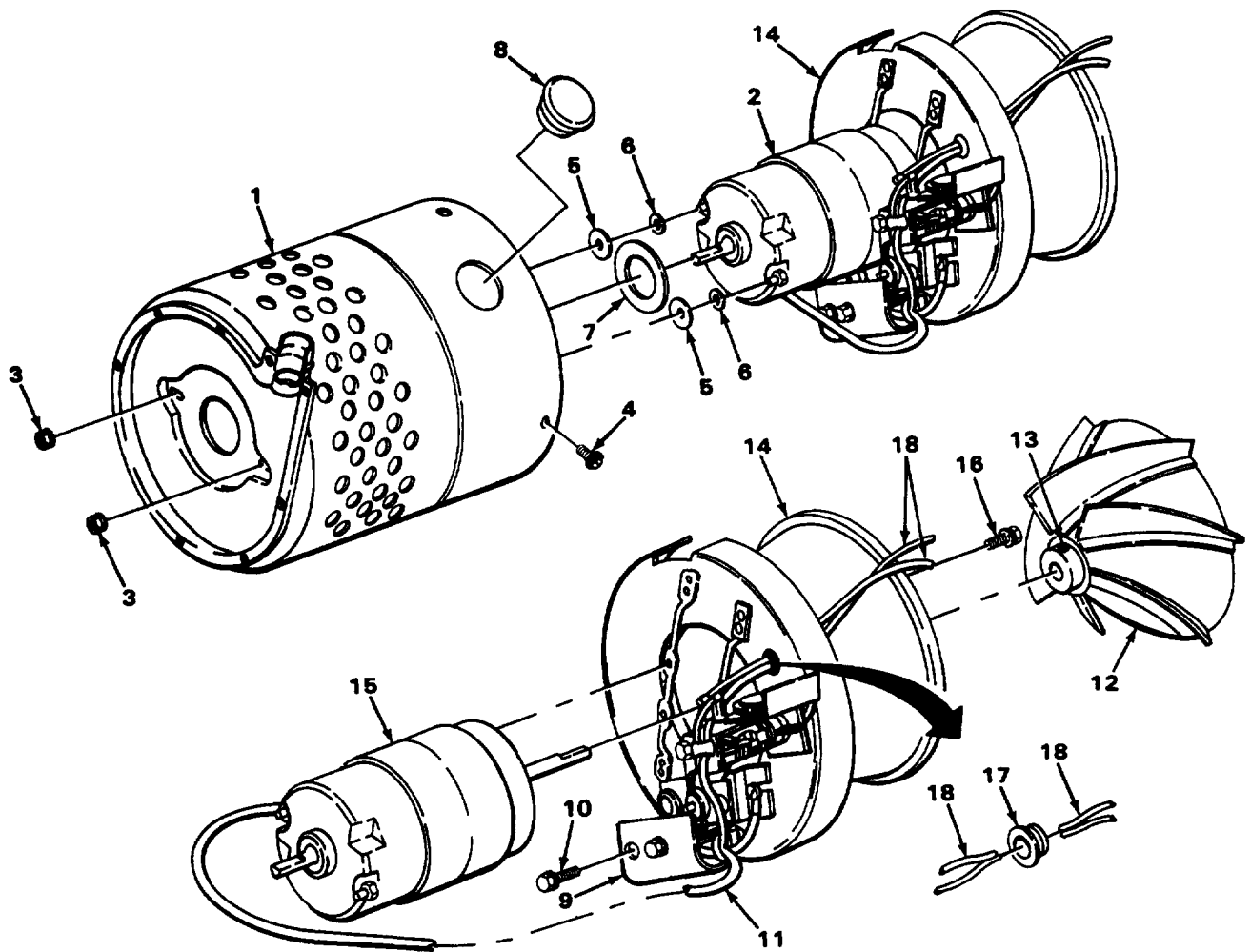

BLOWER ASSEMBLY - STEWART-WARNER 10560M, 10560M24B1 - Continued

LOCATION	ITEM	ACTION REMARKS
ASSEMBLY		
26. Air housing (1)	Grommet (2)	Install.
27. Grommet (2) and air housing (1)	Two leads (3)	Install.
28. Air housing (1)	Motor (4)	Install with long shaft of motor (4) into air housing (1), noting position marks made during disassembly.
29.	Four screw assemblies (5)	Screw in and tighten.
30. Motor (4)	Ventilation blower wheel (6)	Install with setscrew (7) in line with flat side of shaft.
31. Ventilation blower wheel (6)	Setscrew (7)	a. Rotate wheel (6) so setscrew (7) is in line with slot in air housing (1). b. Tighten. Outside edge of ventilation blower wheel must be flush with outside edge of air housing.
32. Diode mounting assembly (8)	Lead (9) and screw assembly (10)	a. Feed lead (8) through, and install terminal. b. Screw in and tighten.
33. Motor (4)	Two washers (11) and small gaskets (12)	Install.
34.	Large gasket (13)	Install.
35. Blower housing (14)	Motor subassembly (15)	a. Install, noting positions marked during disassembly. b. Lineup screw holes and slots.
36. Motor subassembly (15)	Two nut assemblies (16)	Screw on and tighten.
37.	Two screw assemblies (17)	Screw in and tighten.
38. Motor subassembly (15)	Combustion blower wheel (18)	Install with setscrew (19) in line with flat side of shaft.
39. Combustion blower wheel (18)	Setscrew (19)	Tighten.

BLOWER ASSEMBLY - STEWART-WARNER 10560M, 10560M24B1 - Continued

LOCATION	ITEM	ACTION	REMARKS
----------	------	--------	---------

ASSEMBLY - Continued

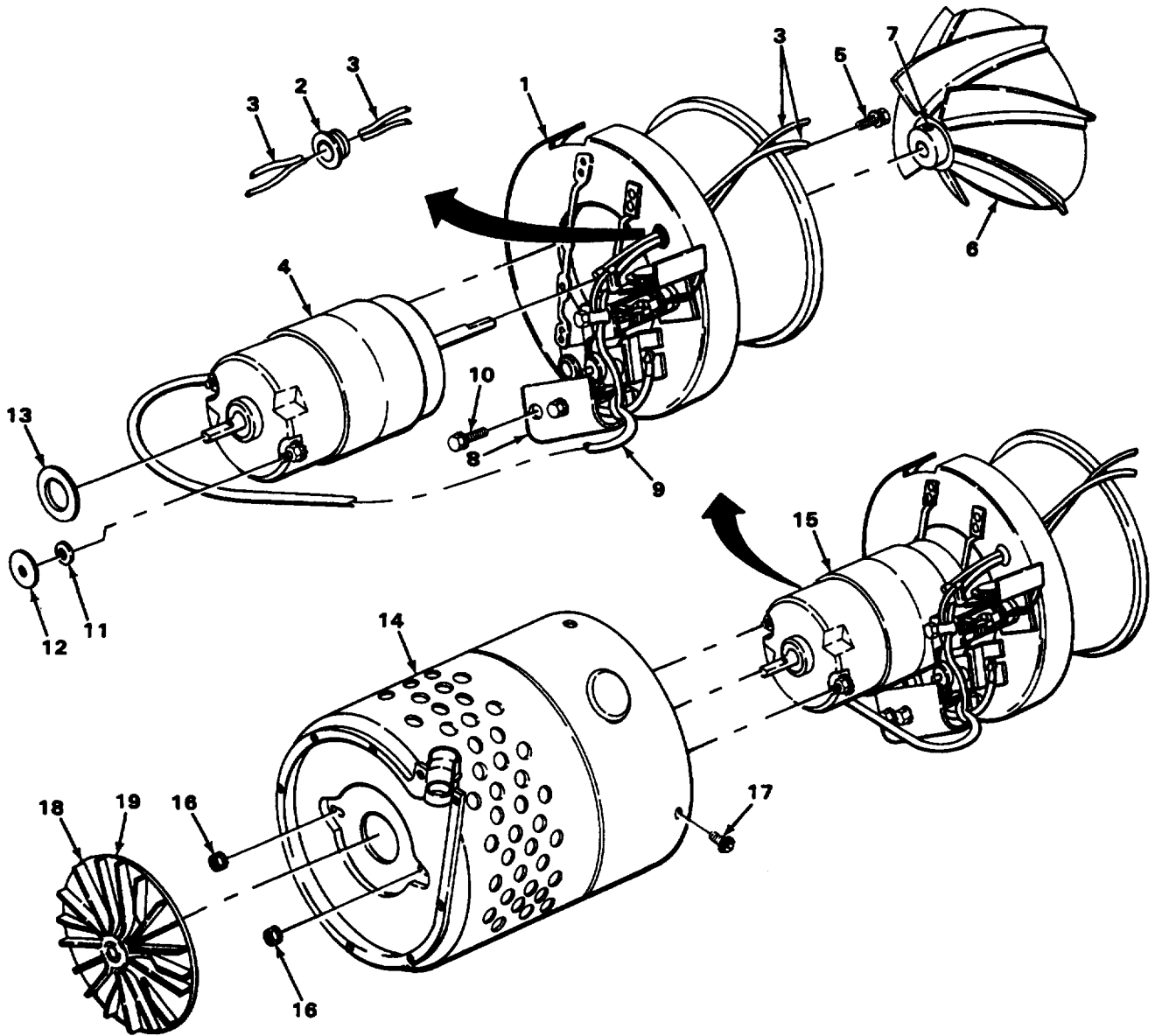

BLOWER ASSEMBLY - STEWART-WARNER 10560M, 10560M24B1 - Continued

LOCATION	ITEM	ACTION REMARKS
ASSEMBLY - Continued		
40. Blower housing (1)	New combustion blower gasket (2) and inlet duct (3)	Install.
41, Inlet duct (3) and blower housing (1)	Nine screws (4)	Screw in and tighten.
42, Inlet adapter (5)	Grommet (6)	Install,
43. Inlet duct (3)	Inlet adapter (5)	Install.
44. Inlet adapter (5) and inlet duct (3)	Screw assembly (7)	Screw in and tighten.
45. Blower housing (1)	Plug (8)	Install.
INSTALLATION		
46. Heater (9)	Grommet (10)	install.
47. Grommet (10)	Two leads (11) and (12)	Push through from inside.
48. Heater (9)	Blower assembly (13)	a. Lineup marked positions and screw holes. b. Push together.
49. Blower assembly (13)	Four screw assemblies (14)	Screw in and tighten.
50.	Hose (15)	Install.
51. Hose (15)	Hose clamp (16)	Tighten.
52. Ignition control (17)	Black lead (11)	Install.
53. Terminal strip (18)	Leads (12) and (19) and screw assembly (20)	a. Place leads (12) and (19) on terminal strip (18) as tagged during removal. b. Screw in.

BLOWER ASSEMBLY - STEWART-WARNER 10560M, 10560M24B1 - Continued

INSTALLATION - Continued

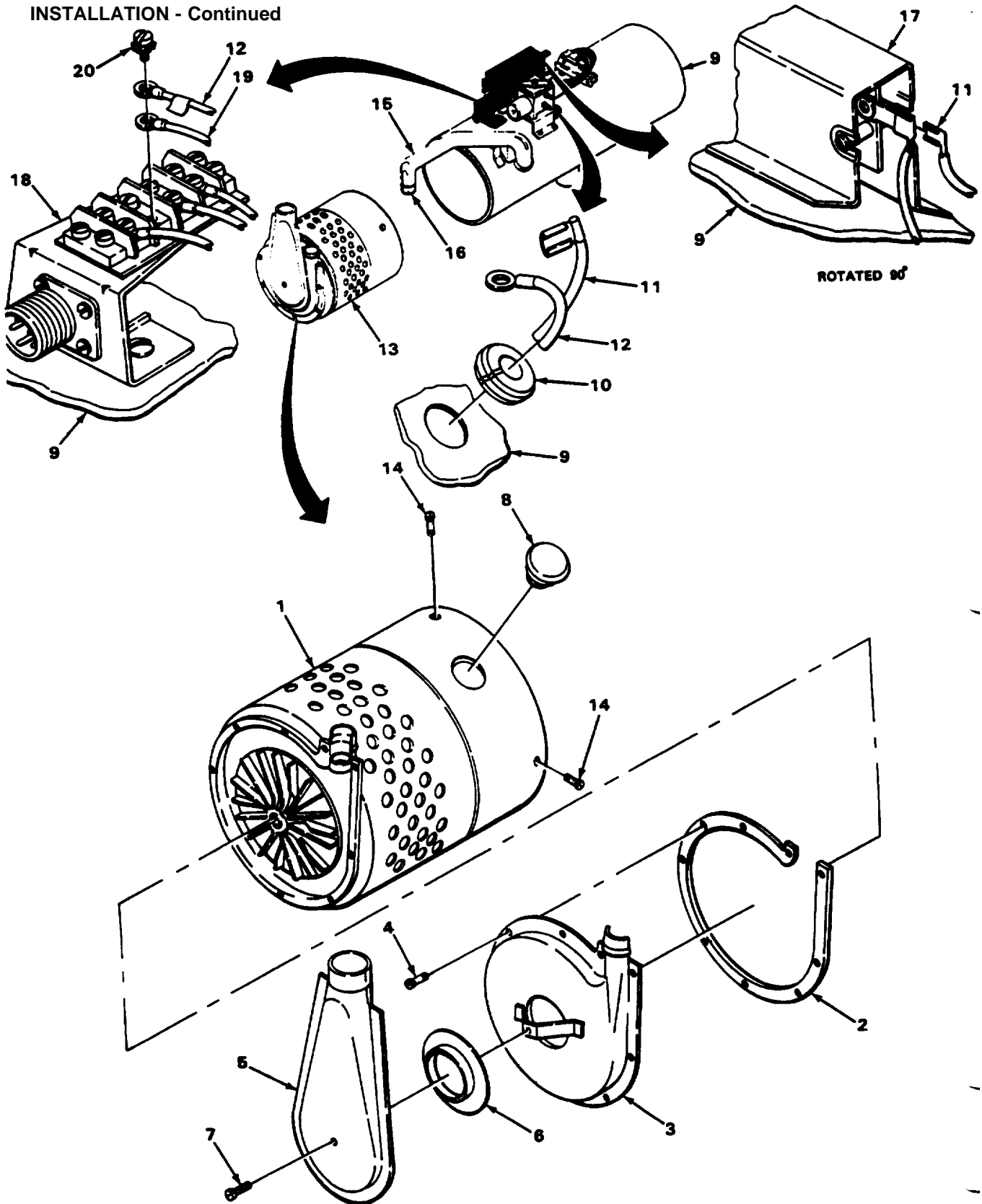

BLOWER ASSEMBLY - STEWART-WARNER 10560M, 10560M24B1 - Continued

LOCATION	ITEM	ACTION	REMARKS
----------	------	--------	---------

INSTALLATION - Continued

NOTE

FOLLOW-ON MAINTENANCE: Install guard (page 2-42).

TASK ENDS HERE

VOLTAGE REGULATOR ASSEMBLY - STEWART-WARNER 10560C24, 10560G

This task covers:

- a. Removal
- b. Installation

INITIAL SETUP

Tools	Personnel Required
Tool Kit, Mechanics Gen (Item 1, Appendix B)	63G
	Equipment Condition
	Blower assembly removed (page 3-99)

LOCATION	ITEM	ACTION
		REMARKS

REMOVAL

NOTE

Tag all wires and terminals to aid during installation (page 2-3).

- | | | |
|---|--------------------------------|---------------------|
| 1. Motor mounting bracket (1) | Lead (2) | Remove. |
| 2. Blower assembly (3) and voltage regulator assembly (4) | Two screw assemblies (5) | Unscrew and remove. |
| 3. Blower assembly (3) | Voltage regulator assembly (4) | Remove. |

INSTALLATION

- | | | |
|---|--------------------------------|----------|
| 4. Blower assembly (3) | Voltage regulator assembly (4) | Install. |
| 5. Blower assembly (3) and voltage regulator assembly (4) | Two screw assemblies (5) | Install. |
| 6. Motor mounting bracket (1) | Lead (2) | Install. |

VOLTAGE REGULATOR ASSEMBLY- STEWART-WARNER 10560M, 10560M24B1 - Continued

LOCATION	ITEM	ACTION	REMARKS
----------	------	--------	---------

INSTALLATION - Continued

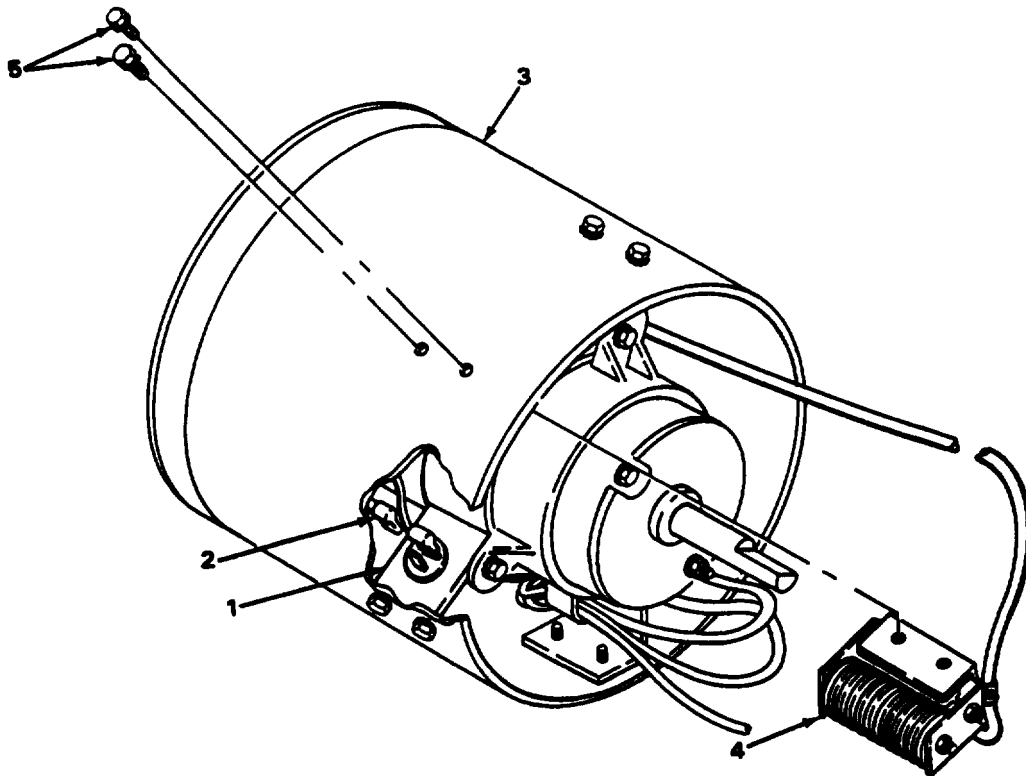

NOTE

FOLLOW-ON MAINTENANCE: Install blower assembly (page 3-99).

TASK ENDS HERE

VOLTAGE REGULATOR ASSEMBLY - STEWART-WARNER 10560M, 10560M24B1

This task covers:

- a. Removal
- b. Installation

INITIAL SETUP

Tools	Personnel Required
Tool Kit, Mechanics Gen (Item 1, Appendix B) Key, socket-head screw, 3/32-inch (Item 2, Appendix B)	63G Equipment Condition
Material/Parts	Blower assembly removed (page 3-105)
Gasket, combustion blower Tags, marking (Item 9, Appendix C) Tie wraps (two required) (Item 11, Appendix C)	

LOCATION	ITEM	ACTION REMARKS
----------	------	-------------------

REMOVAL

NOTE

Tag all wires and terminals to aid during installation (page 2-3).

1. Blower housing (1)	Plug (2)	Remove.
2. Blower housing (1) and ventilation blower wheel (3)	Setscrew (4)	a. Rotate wheel (3) so set-screw (4) is in line with hole in housing (1). b. Unscrew part way.
3. Air housing (5) and motor (6)	Ventilation blower wheel (3)	Remove.
4.	Four screw assemblies (7)	Unscrew and remove.
5. Motor (6) and blower housing assembly (1)	Air housing (5)	Remove.
6. Voltage regulator assembly (8)	Tie wrap (9)	a. Cut off. b. Discard.
7.	Two leads (10)	Remove connector.
8. Voltage regulator assembly (1) and air housing (2)	Screw (3)	Unscrew and remove.
9. Air housing (2)	Voltage regulator assembly (1)	Remove.

VOLTAGE REGULATOR ASSEMBLY - STEWART-WARNER 10560M, 10560M24B1 - Continued

LOCATION	ITEM	ACTION REMARKS
----------	------	-------------------

REMOVAL - Continued

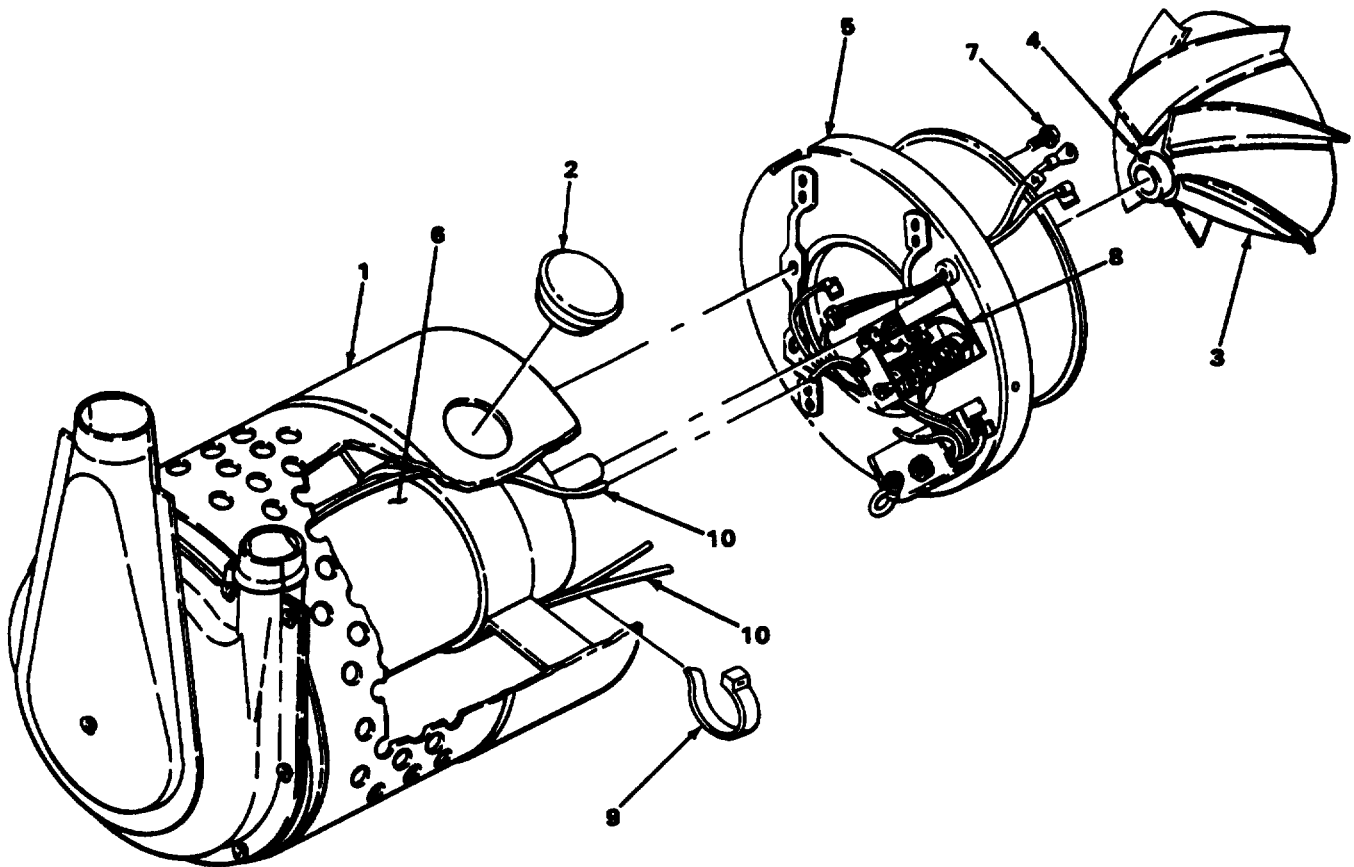

VOLTAGE REGULATOR ASSEMBLY - STEWART-WARNER 10560M, 10560M24B1 - Continued

LOCATION	ITEM	ACTION REMARKS
INSTALLATION		
10. Air housing (2)	Voltage regulator assembly (1)	Install.
11. Voltage regulator assembly (1) and air housing (2)	Screw (3)	Screw in and tighten.
12. Voltage regulator assembly (1)	Two leads (4)	Install.
13. Voltage regulator assembly (1) and two leads (4)	New tie wrap (5)	Install, and cut off excess.
14. Blower housing (6) and motor (7)	Air housing (2)	Push in, and line up holes in air housing (2) with holes in motor (7).
15. Air housing (2) and motor (7)	Four screw assemblies (8) ,	Screw in and tighten.
16.	Ventilation blower wheel (9)	Slide on with setscrew (10) in line with flat side of shaft,
17. Blower housing (6) and ventilation blower wheel (9)	Setscrew (10)	a. Rotate wheel (9) so set-screw (10) is in line with hole in housing (6). b. Tighten.
18. Blower housing (6)	Plug (11)	Install.

VOLTAGE REGULATOR ASSEMBLY - STEWART-WARNER 10560M, 10560M24B1 - Continued

LOCATION	ITEM	ACTION	REMARKS
----------	------	--------	---------

INSTALLATION - Continued

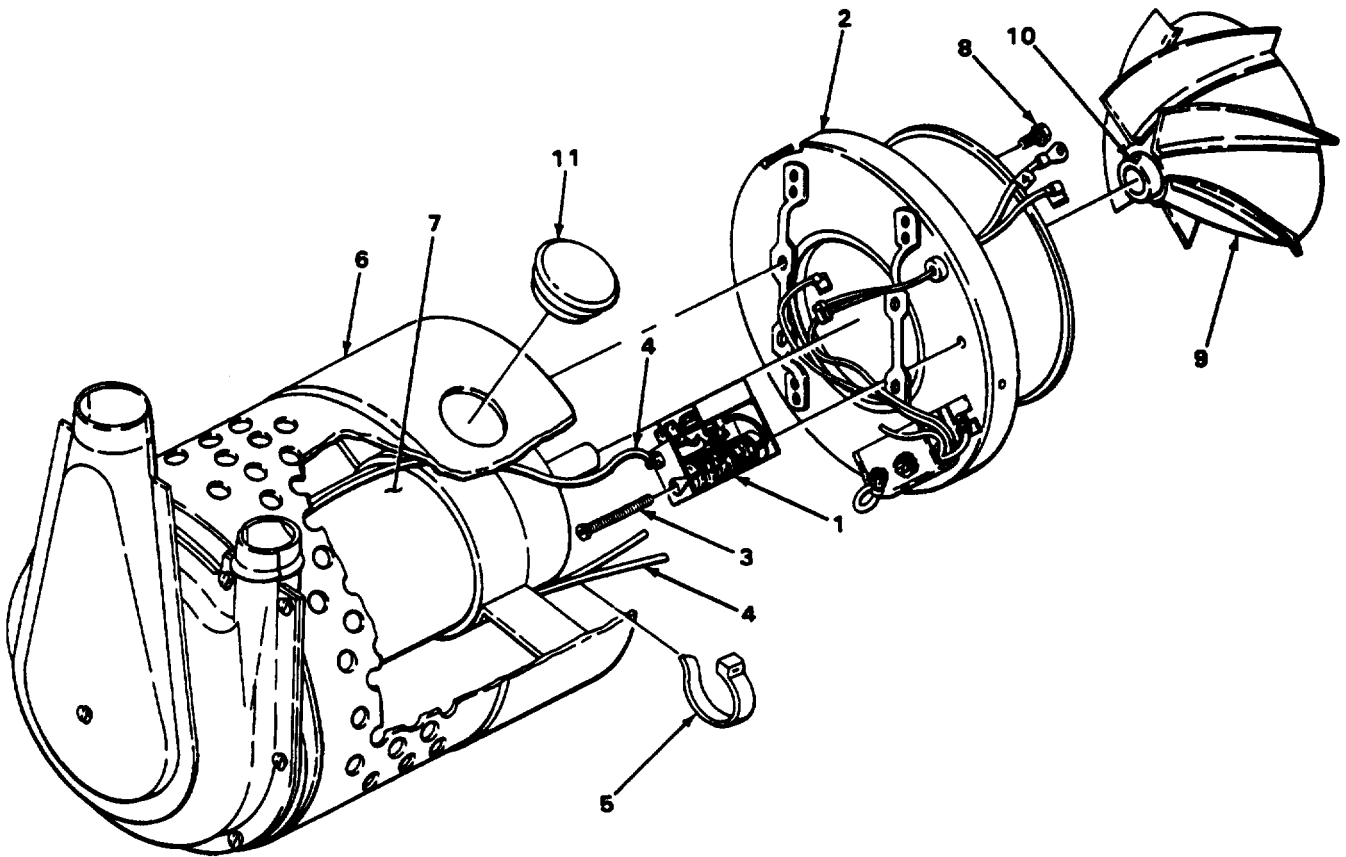

NOTE
FOLLOW-ON MAINTENANCE: Install blower assembly (page 3-105).

TASK ENDS HERE

SEMICONDUCTOR DEVICE (DIODE MOUNTING ASSEMBLY) - STEWART-WARNER 10560C24, 10560G

This task covers:

- a. Removal
 - b. installation
-

INITIAL SETUP

Tools

Tool Kit, Mechanics Gen (Item 1, Appendix B)

Personnel Required

63G

Equipment Condition

Blower assembly removed (page 3-99)

LOCATION	ITEM	ACTION	REMARKS
----------	------	--------	---------

REMOVAL

1. Motor (1)	Nut assembly (2) and lead (3)	Unscrew and remove.	
2. Motor mounting bracket (4)	Lead (5)	Remove.	
3. Semiconductor device (6)	Screw (7) and lead (8)	Unscrew and remove.	
4. Blower assembly housing (9) and semiconductor device (6)	Two screw assemblies (10)	Unscrew and remove.	
5. Blower assembly housing (9)	Semiconductor device (6)	Remove.	
6. Semiconductor device (6) and strap (11)	Screw (12)	Unscrew and remove.	
7. Semiconductor device (6)	Strap (11)	Remove.	

INSTALLATION

8. Semiconductor device (6)	Strap (11)	Install.	
9. Semiconductor device (6) and strap (11)	Screw (12)	Screw in and tighten.	
10. Blower assembly housing (9)	Semiconductor device (6)	Install.	
11. Blower assembly housing (9) and semiconductor device (6)	Two screw assemblies (10)	Screw in and tighten.	

SEMICONDUCTOR DEVICE (DIODE MOUNTING ASSEMBLY) - STEWART-WARNER 10560C24, 10560G - Continued

LOCATION	ITEM	ACTION REMARKS
INSTALLATION - Continued		
12. Semiconductor device (6)	Lead (8) and screw (7)	Screw in and tighten.
13. Motor mounting bracket (4)	Lead (5)	Install.
14. Motor (1)	Lead (3) and nut assembly (2)	Screw in and tighten.

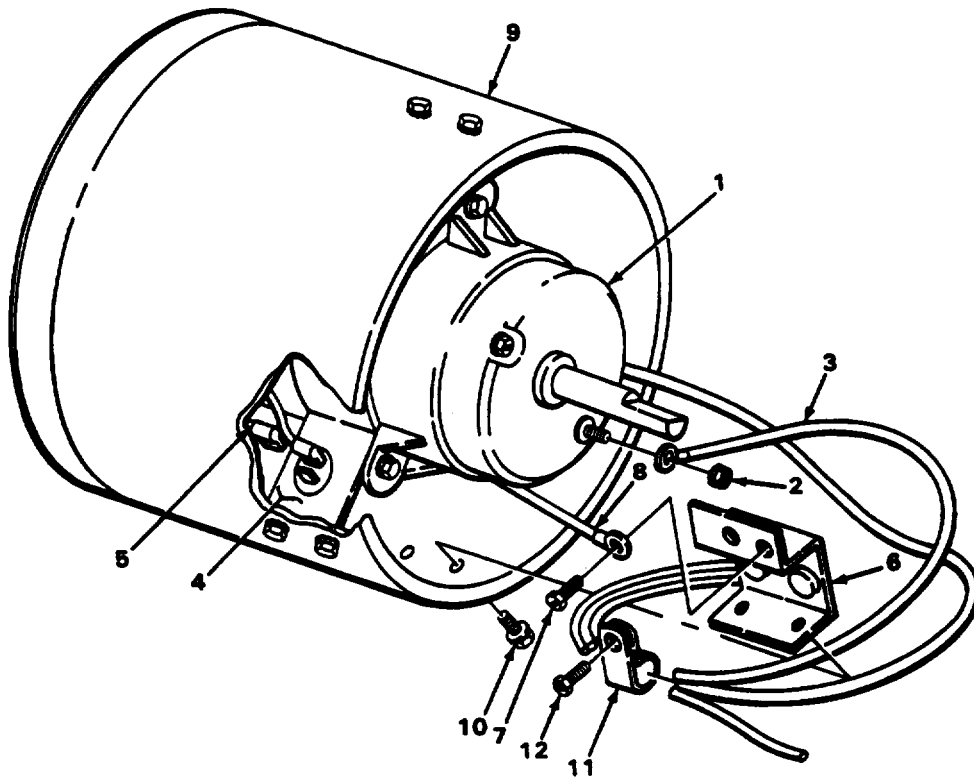

NOTE
 FOLLOW-ON MAINTENANCE: Install blower assembly (page 3-99).

TASK ENDS HERE

DIODE MOUNTING ASSEMBLY - STEWART-WARNER 10560M, 10560M24B1

This task covers:

- a. Removal
- b. installation

INITIAL SETUP

Tools	Personnel Required
Tool Kit, Mechanics Gen (Item 1, Appendix B) Key, socket-head screw, 3/32-inch (Item 2, Appendix B)	63G Equipment Condition
Materials/Parts	Blower assembly removed (page 3-105)
Gasket, combustion blower Tags, marking (Item 9, Appendix C) Tie wraps (two required) (Item 11, Appendix C)	

LOCATION	ITEM	ACTION	REMARKS
----------	------	--------	---------

REMOVAL

NOTE

Tag all wires and terminals to aid during installation (page 2-3).

- | | | |
|--|------------------------------|--|
| 1. Blower housing (1) | Plug (2) | Pry out. |
| 2. Blower housing (1) and ventilation blower wheel (3) | Setscrew (4) | a. Rotate wheel (3) so setscrew (4) is in line with hole in housing (1).
b. Unscrew part way. |
| 3. Air housing (5) and motor (6) | Ventilation blower wheel (3) | Remove. |
| 4. | Four screw assemblies (7) | Unscrew and remove. |
| 5. Motor (6) and blower housing (1) | Air housing (5) | Remove. |

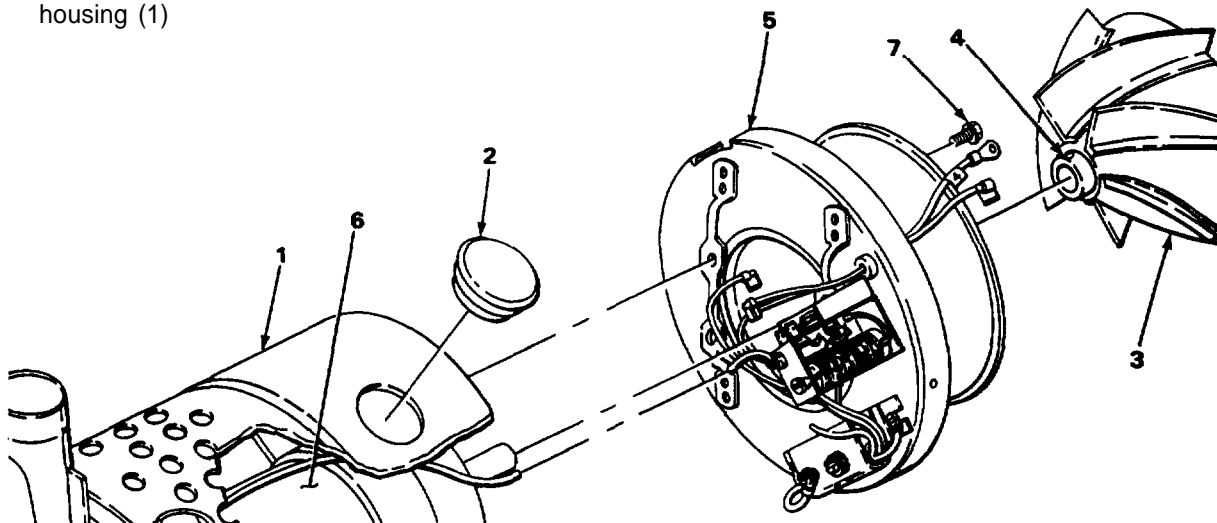

DIODE MOUNTING ASSEMBLY - STEWART-WARNER 10560M, 10560M24B1 Continued

LOCATION	ITEM	ACTION REMARKS
REMOVAL - Continued		
6. Voltage limiter assembly (1) and diode mounting assembly (2)	Two tie wraps (3)	a. Cutoff. b. Discard.
7. Voltage limiter assembly (1)	Lead (4)	Remove.
8. Grommet (5)	Lead (6)	Pull through.
9. Diode mounting assembly (2)	Screw assembly (7) and lead (8)	a. Unscrew and remove. b. Pull wire lead (8) out through diode mounting assembly (2).
10.	Two screw assemblies (9) and lead (8)	Unscrew and remove.
11. Air housing (11)	Diode mounting assembly (2)	Remove.
INSTALLATION		
12. Air housing (11)	Diode mounting assembly (2)	Install.
13. Diode mounting assembly (2)	Two screw assemblies (9) and lead (10)	Screw in and tighten.
14.	Lead (8) and screw assembly (7)	a. Push wire lead (8) through diode mounting assembly (2). b. Screw in and tighten.
15. Voltage limiter assembly (1)	Lead (4)	Install.
16. Grommet (5)	Lead (6)	Push through.
17. Diode mounting assembly (2) and voltage limiter assembly (1)	Two new tie wraps (3)	Install, and cut off excess.
18. Blower housing (12) and motor (13)	Air housing (11)	Push in, and line up holes in air housing (11) with holes in motor (13).
19. Air housing (11) and motor (13)	Four screw assemblies (14)	Screw in and tighten.
20.	Ventilation blower wheel (15)	Slide on with setscrew (4) in line with flat side of shaft.

DIODE MOUNTING ASSEMBLY - STEWART-WARNER 10560M, 10560M24B1 Continued

LOCATION	ITEM	ACTION	REMARKS
----------	------	--------	---------

INSTALLATION - Continued

21. Blower housing (12) and ventilation blower wheel (15)	Setscrew (16)	a. Rotate wheel (3) so set-screw is in line with hole in housing (1). b. Tighten,	
22. Blower housing (12)	Plug (17)	install.	

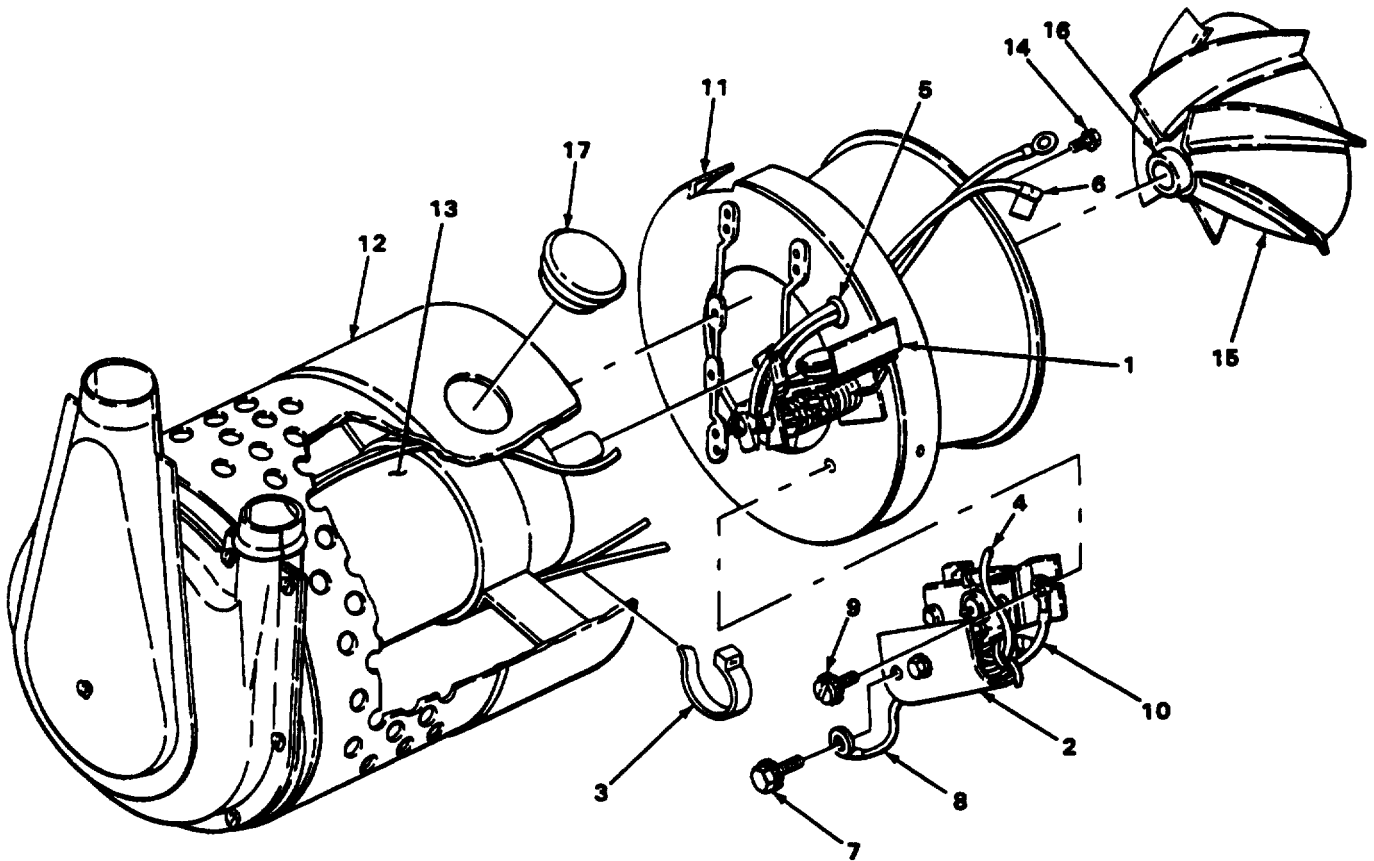

NOTE
FOLLOW-ON MAINTENANCE: install blower assembly (page 3-105).

TASK ENDS HERE

BURNER ASSEMBLY - STEWART-WARNER 10560C24, 10560G

This task covers:

- a. Removal
- b. Installation

INITIAL SETUP

Tools

Tool Kit, Mechanics Gen (Item 1, Appendix B)

Personnel Required

63G

Equipment Condition

Blower assembly removed (page 3-99)
 Igniter removed (page 2-49)

LOCATION	ITEM	ACTION	REMARKS
----------	------	--------	---------

REMOVAL

1. Secondary blower housing (1) and igniter tubs (2)	Screw (3)	Unscrew and remove.	
2. Secondary blower housing (1)	Igniter tube (2)	Remove.	
3. Fuel tube (4)	Two nuts (5)	Unscrew.	
4. Burner (6) to fuel regulator valve (7)	Fuel tube (4)	Remove.	
5. Heater housing (8)	Seal (9)	Remove.	
6. Burner (6)	Secondary blower housing (1)	Remove.	
7.	Six screws (10)	Unscrew and remove.	
8. Heat exchanger(11)	Burner (6)	Unscrew and remove.	

INSTALLATION

9. Heat exchanger(n)	Burner (6)	Instail.	
10. Burner (6)	Six screws (10)	Screw in and tighten.	
11.	Secondary blower housing (1)	Install.	
12. Heater housing (8)	Seal (9)	Install.	
13. Burner (6) to fuel regulator valve (7)	Fuel tube (4)	Install.	
14. Fuel tube (4)	Two nuts (5)	Screw in and tighten.	

BURNER ASSEMBLY - STEWART-WARNER 10560C24, 10560G - Continued

LOCATION	ITEM	ACTION	REMARKS
----------	------	--------	---------

INSTALLATION - Continued

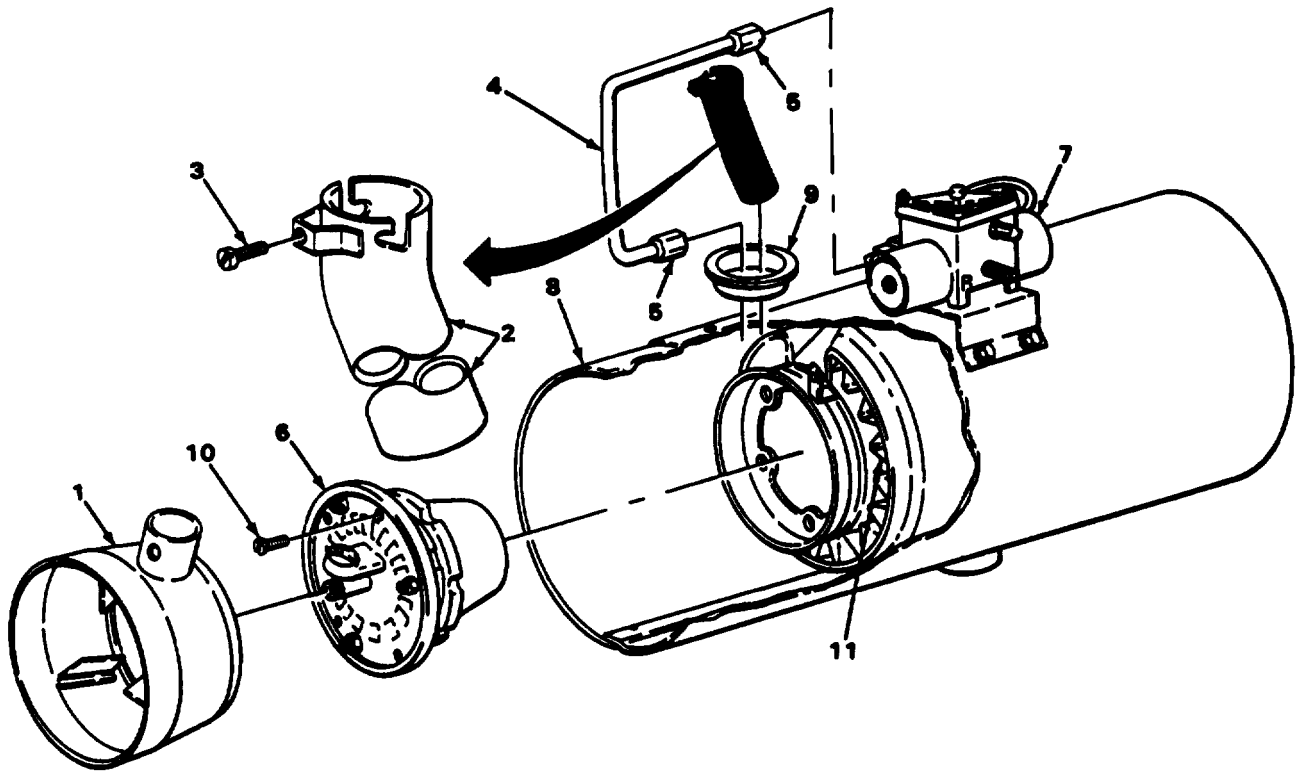

NOTE
FOLLOW-ON MAINTENANCE:

1. Install blower assembly (page 3-99)
2. Install igniter (page 2-49).

TASK ENDS HERE

BURNER ASSEMBLY - STEWART-WARNER 10560M, 10560M24B1

This task covers:

- a. Removal
 - b. Installation
-

INITIAL SETUP

Tools	Personnel Required
Tool Kit, Mechanics Gen (Item 1, Appendix B)	63G
Materials/Parts	Equipment Condition
Preformed packing	Blower assembly removed (page 3-105) Igniter removed (page 2-49)

LOCATION	ITEM	ACTION REMARKS
----------	------	-------------------

REMOVAL

NOTE

Tag all wires and terminals to aid during installation (page 2-3).

1. Adapter (1)	Screw assembly (2), washer (3), cap (4), and preformed packing (5)	a. Unscrew and remove. b. Pry cap (4) off. c. Discard packing (5).
2. Burner (6)	Two screws (7) and bracket (8)	a. Unscrew and remove. b. Remove bracket (8).
3.	Screw assembly (9) and igniter tube (10)	a. Unscrew and remove. b. Remove tube (10).
4. Fuel tube (11)	Two nuts (12)	Unscrew until threads are free.
5. Burner (6) to fuel control/metering valve (13)	Fuel tube (11)	Remove.
6. Heater housing (14)	Seal (15)	Pry out.

BURNER ASSEMBLY - STEWART-WARNER 10560M, 10560M24B1 - Continued

LOCATION	ITEM	ACTION	REMARKS
----------	------	--------	---------

REMOVAL - Continued

7. Burner (6)	Four screws (16)	Unscrew and remove.	
8. Heat exchanger (17)	Burner (6)	Remove.	

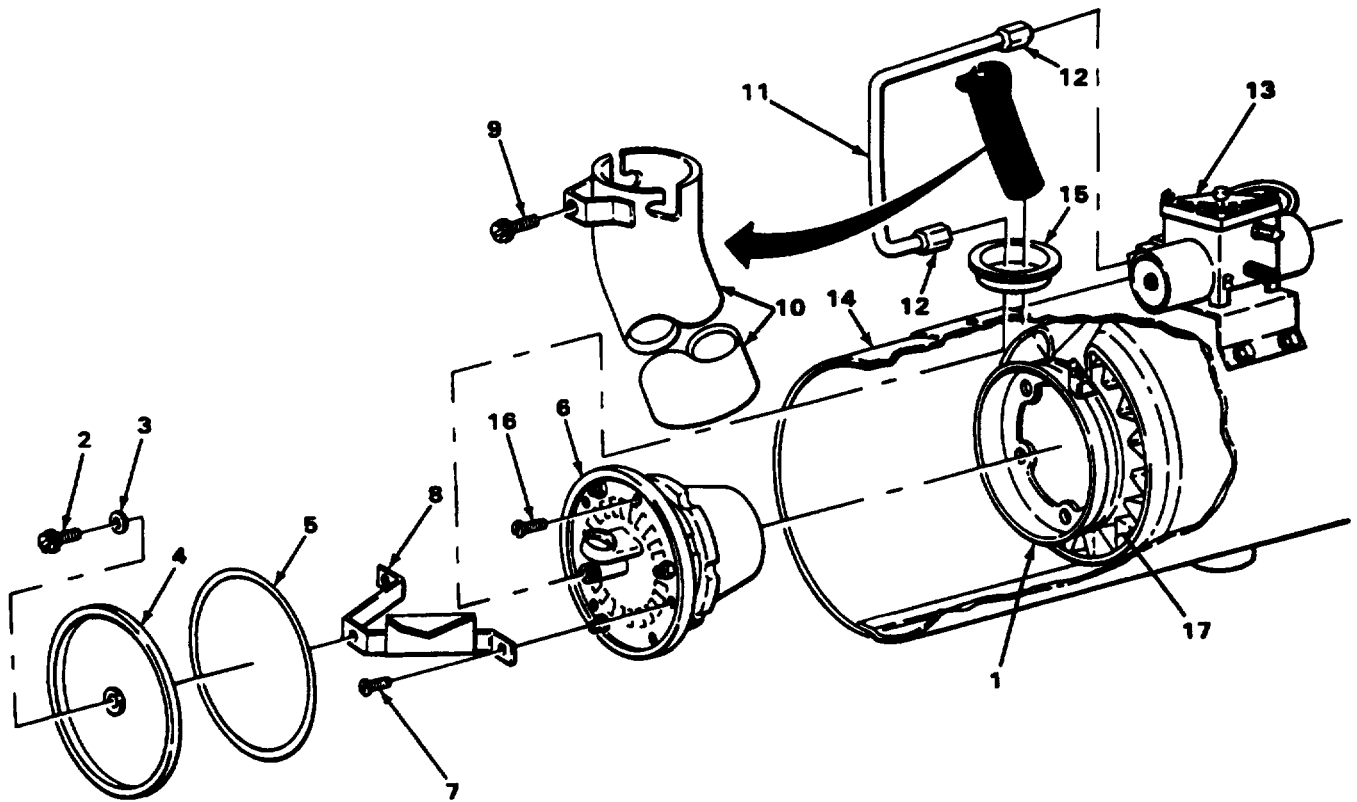

BURNER ASSEMBLY - STEWART-WARNER 10560M, 10560M24B1 - Continued

LOCATION	ITEM	ACTION REMARKS
INSTALLATION		
9. Heat exchanger (1)	Burner (2)	Install.
10. Burner (2)	Four screws (3)	Screw in and tighten into two top and two bottom holes.
11. Heater housing (4)	Seal (5)	Install.
12. Burner (2) to fuel controll/metering valve (6)	Fuel tube (7)	a. Install. b. Push until firmly seated.
13. Fuel tube (7)	Two nuts (8)	Screw in and tighten.
14. Burner (2)	Igniter tube (9)	Install.
15. Igniter tube (9)	Screw assembly (10)	Screw in and tighten.
16. Burner (2)	Bracket (11)	Install. New brackets do not have wide flange, older brackets do. Either can be used. Wide part of older bracket must go toward air Inlet tube.
17. Bracket (11)	Two screws (12)	Screw in and tighten.
18. Cap (13)	New preformed packing (14)	Install.
19. Adapter (15)	Cap (13)	Install.
20. Cap (13)	Screw assembly (16) and washer (17)	Screw in and tighten.

BURNER ASSEMBLY - STEWART-WARNER 10560M, 10560M24B1 - Continued

LOCATION	ITEM	ACTION	REMARKS
----------	------	--------	---------

INSTALLATION - Continued

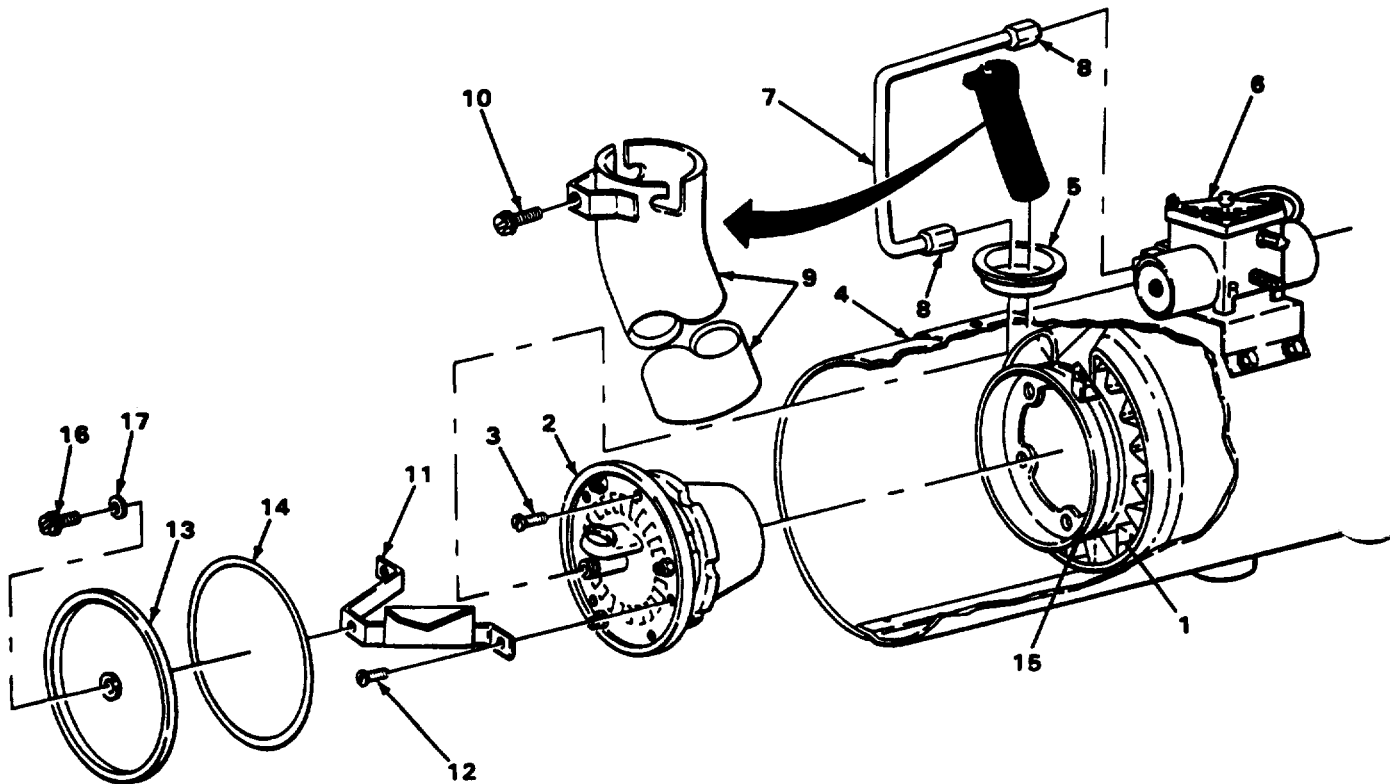

NOTE

FOLLOW-ON MAINTENANCE:

1. Install Igniter (page 2-49)
2. Install blower assembly (page 3-105)

TASK END HERE

BURNER REPAIR - STEWART-WARNER 10560C24, 10560M, 10560M24B1, 10560G

This task covers:

- a. Disassembly
- b. Cleaning/Inspection
- c. Assembly

INITIAL SETUP

Tools	Personnel Required
Tool Kit, Mechanics Gen (Item 1, Appendix B)	63G
Materials/Parts	Equipment Condition
Burner repair kit Wire (Item 12, Appendix C)	Burner removed (10560C24, 10560G - (page 3-125); (10560M, 10560M24B1 - page 3-127)

LOCATION	ITEM	ACTION	REMARKS
----------	------	--------	---------

NOTE

Do not attempt to repair a burner if it has been used for more than 400 hours. A burner with this much usage should be replaced.

DISASSEMBLY

1. Three screws (1)	Three jamnuts (2)	Unscrew and remove. Later model burners may not have jamnuts.
2. Plate (3)	Three nuts (4), three screws (1), and cup (5)	a. Unscrew and remove. b. Remove cup (5).
3. Wick and vaporizer assembly (6)	Screw assembly (7) and shield (8)	a. Unscrew and remove. b. Remove shield (8).
4.	Two washers (9)	Remove and discard.

BURNER REPAIR - STEWART-WARNER 10560C24, 10560M, 10560M24B1, 10560G - Continued

LOCATION	ITEM	ACTION REMARKS
----------	------	-------------------

DISASSEMBLY - Continued

5. Plate (3)	Wick and vaporizer assembly (6)	a. Detach wick from support, b. Remove and discard.
6.	Retaining washer (10) and two slotted washers (11)	Remove and discard.

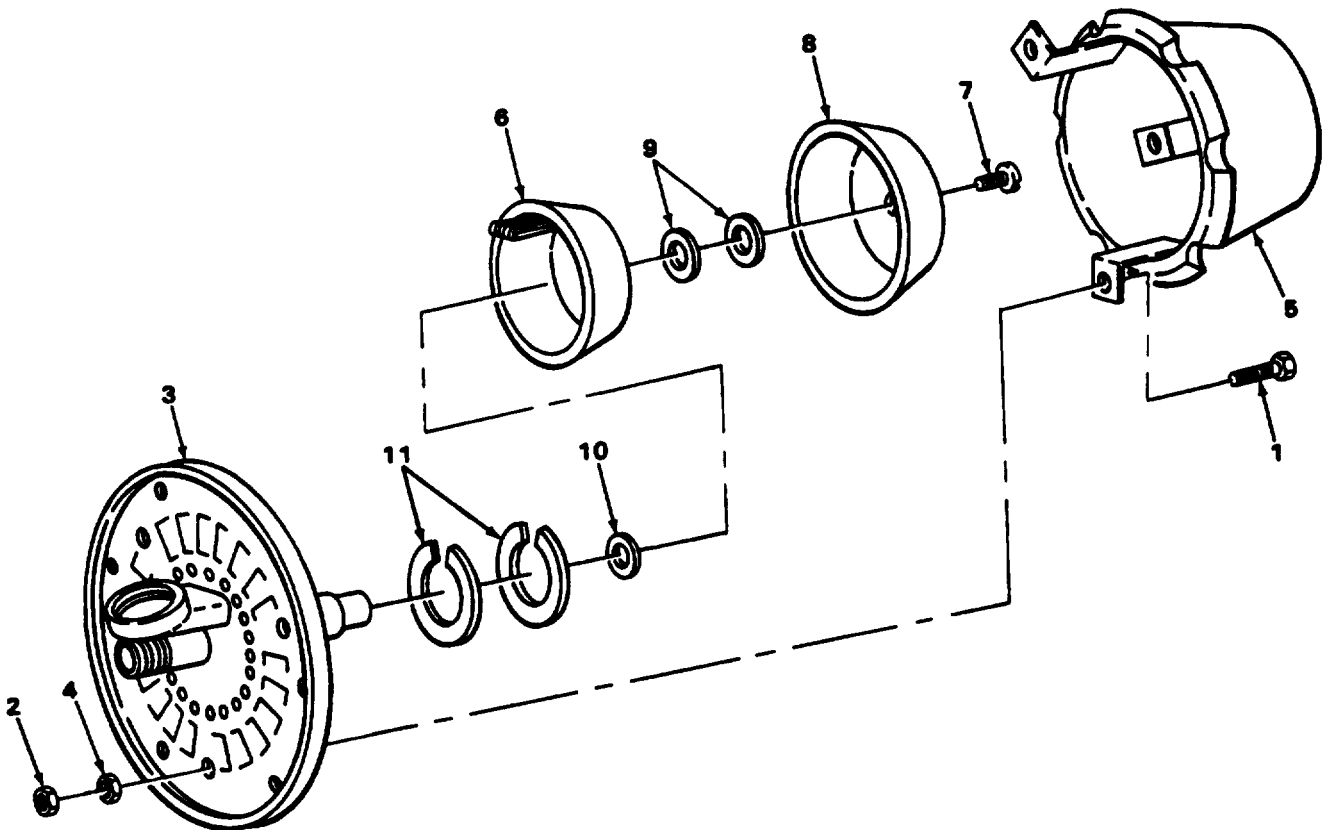

BURNER REPAIR - STEWART-WARNER 10560C24, 10560M, 10560M24B1, 10560G - Continued

LOCATION	ITEM	ACTION REMARKS
CLEANING/INSPECTION		
7. Plate (1)	Cup (2) and shield (3)	a. Clean with wire brush. b. Inspect for damage. Replace entire burner If either part is cracked, warped, or burned through.
8.	Plate (1)	a. Clean with wire brush. b. Clear out all vent holes. c. Remove any wick particles left in igniter pocket. d. Inspect for damage. Replace entire burner if plate is cracked, warped, or burned through.
ASSEMBLY		
9. Plate (1)	Two new slotted washers (4)	Position as shown.
10.	New retaining washer (5)	a. Install. b. Press into place.
11.	New wick and vaporizer assembly (6)	a. Install. b. Using thin wire wrapped around wick, pull wick into igniter pocket. c. Take thin wire off wick. d. Hook wick onto support in igniter pocket (7). e. Pull wick through vaporizer until it is drawn uptight. f. Cutoff excess.
12. Wick and vaporizer assembly (6)	Two new washers (8), shield (3), and screw (9)	a. Install. b. Screw in and tighten.
13. Plate (1)	Cup (2), three screws (10), and nuts (11)	a. Install. b. Screw in and tighten.

BURNER REPAIR - STEWART-WARNER 10560C24, 10560M, 10560M24B1, 10560G - Continued

LOCATION	ITEM	ACTION REMARKS
----------	------	-------------------

ASSEMBLY - Continued

14. Three screws (1 O)	Three jamnuts (12)	Screw on and tighten, Later model burners may not have jamnuts.
------------------------	--------------------	---

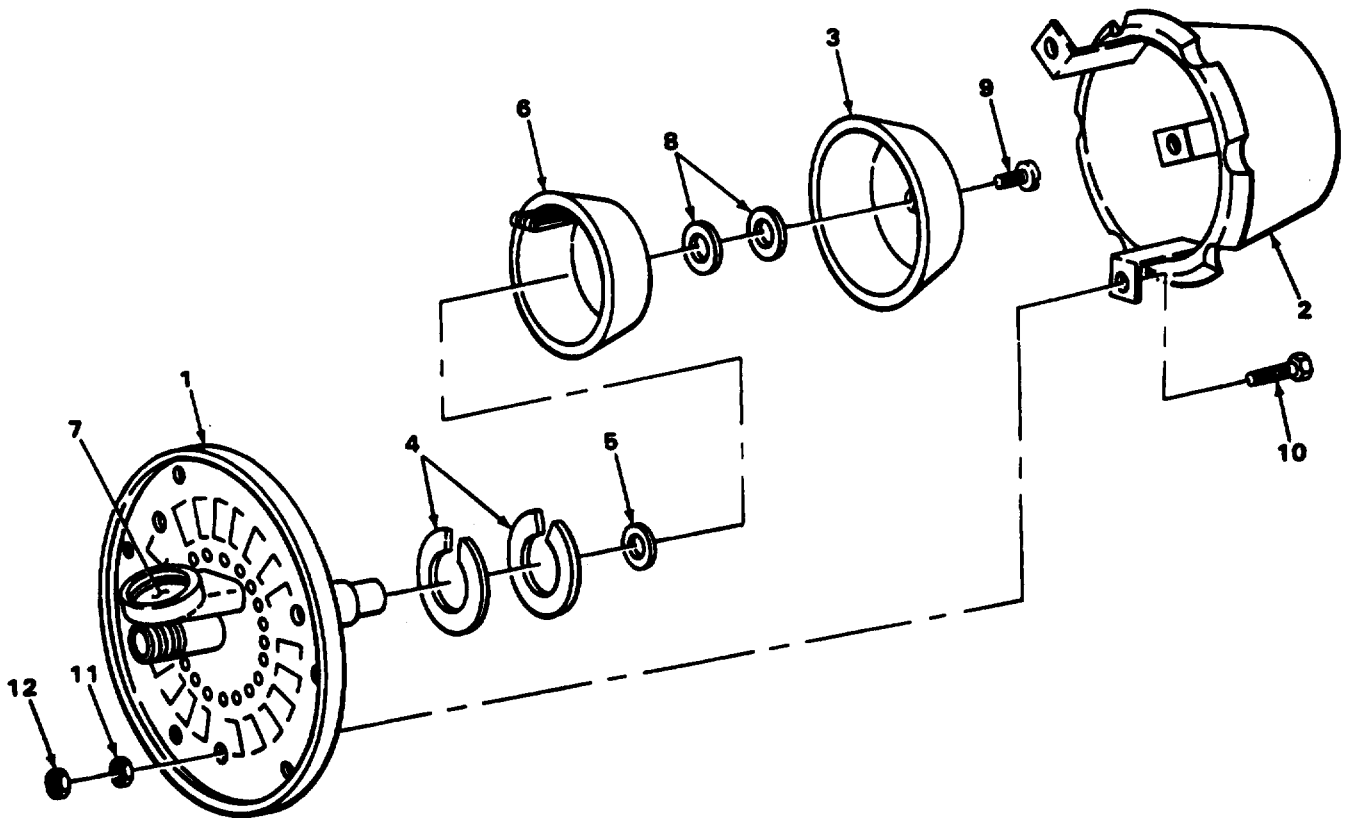

NOTE
 FOLLOW-ON MAINTENANCE: Install burner (10560C24, 10560G - page 3-125);
 (10560M, 10560M24B1 - page 3-127).

TASK ENDS HERE

HOOD - ESPAR V7S

This task covers:

- a. Removal
- b. Installation

INITIAL SETUP

Tools	Personnel Required
Tool Kit, Mechanics Gen (Item 1, Appendix B)	63G

LOCATION	ITEM	ACTION	REMARKS
----------	------	--------	---------

REMOVAL

1. Stud (1)	Knurled nut (2)	Unscrew as far as necessary.
2. Heater (3)	Hood (4)	Remove.

INSTALLATION

CAUTION

Make sure no wires are pinched between hood and heater.

3. Heater (3)	Hood (4)	Install.
4. Stud (1)	Knurled nut (2)	Screw in and tighten.

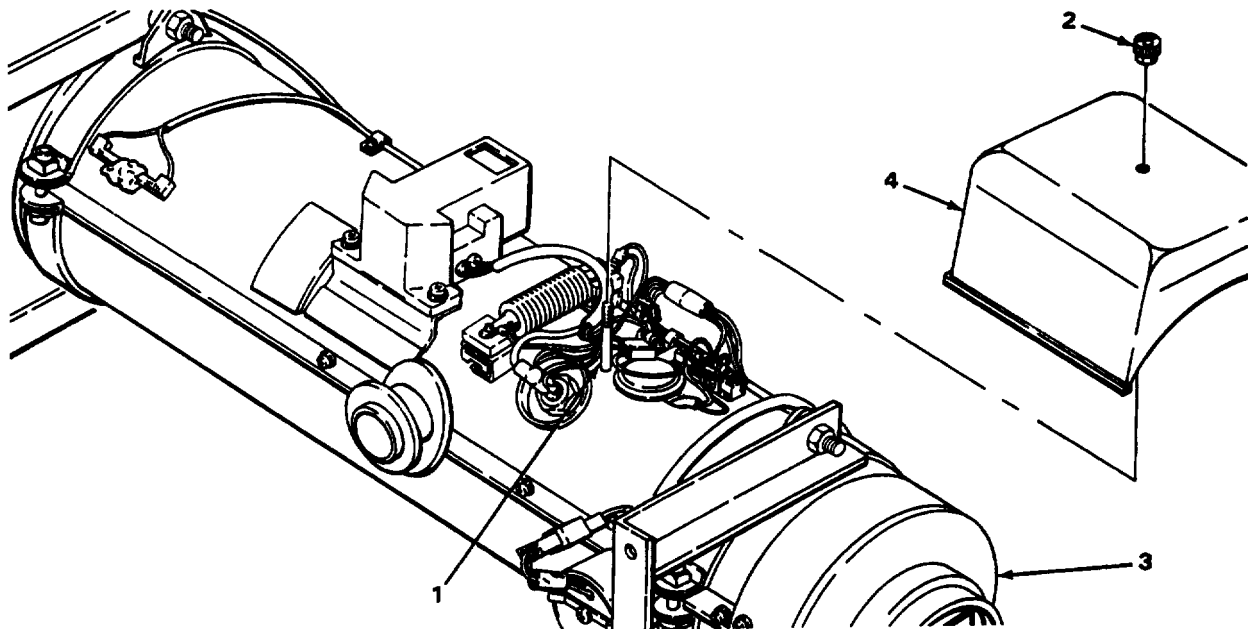

TASK ENDS HERE

IGNITION SPARK GENERATOR - ESPAR V7S

This task covers:

- a. Removal
 - b. installation
-

INITIAL SETUP

Tools	Personnel Required
Tool Kit, Mechanics Gen (Item 1, Appendix B)	63G
Materials/Parts	Equipment Condition
Sealant, silicon (Item 6, Appendix C) Tags, marking (Item 9, Appendix C)	Hood removed (page 3-135)

LOCATION	ITEM	ACTION	REMARKS
----------	------	--------	---------

REMOVAL

NOTE

Tag all wires and terminals to aid during installation (page 2-3).

1. Glow plug (1)	Socket (2)	Remove.	
2. Fixed wire resistor (3)	Lead (4)	a. Cutoff sealant. b. Remove.	
3. Terminal board (5)	Lead (6)	a. Cut off sealant. b. Remove.	
4. Ignition spark generator (7)	Two screws (8) and washers (9)	Unscrew and remove.	
5. Clamp (10)	Screw (11)	Unscrew and remove.	
6. Heater (12)	Ignition spark generator (7)	Remove.	
7. Lead (13)	Socket (2)	Unscrew and remove.	
8. Socket (2)	Terminal (14)	Remove.	

INSTALLATION

9. Socket (2)	Terminal (14)	Install.	
10. Lead (13)	Socket (2)	Screw in.	
11. Heater (12)	Ignition spark generator (7)	a. Make sure ground lug (15) is around mounting hole. b. Install.	
12. Clamp (10)	Screw (11) and ignition spark generator (7)	a. Put generator (7) on wire harness clamp (10). b. Tighten screw (11).	
13. Ignition spark generator (7)	Two screws (8) and washers (9)	Screw in and tighten.	

IGNITION SPARK GENERATOR - ESPAR V7S - Continued

LOCATION	ITEM	ACTION	REMARKS
----------	------	--------	---------

INSTALLATION - Continued

14. Terminal board (5)	Lead (6)	a. Install. b. Apply sealant to terminal and lead.	
15. Fixed wire resistor (3)	Lead (4)	a. Install. b. Apply sealant to terminal and lead.	
16. Glow plug (1)	Socket (2)	Install.	

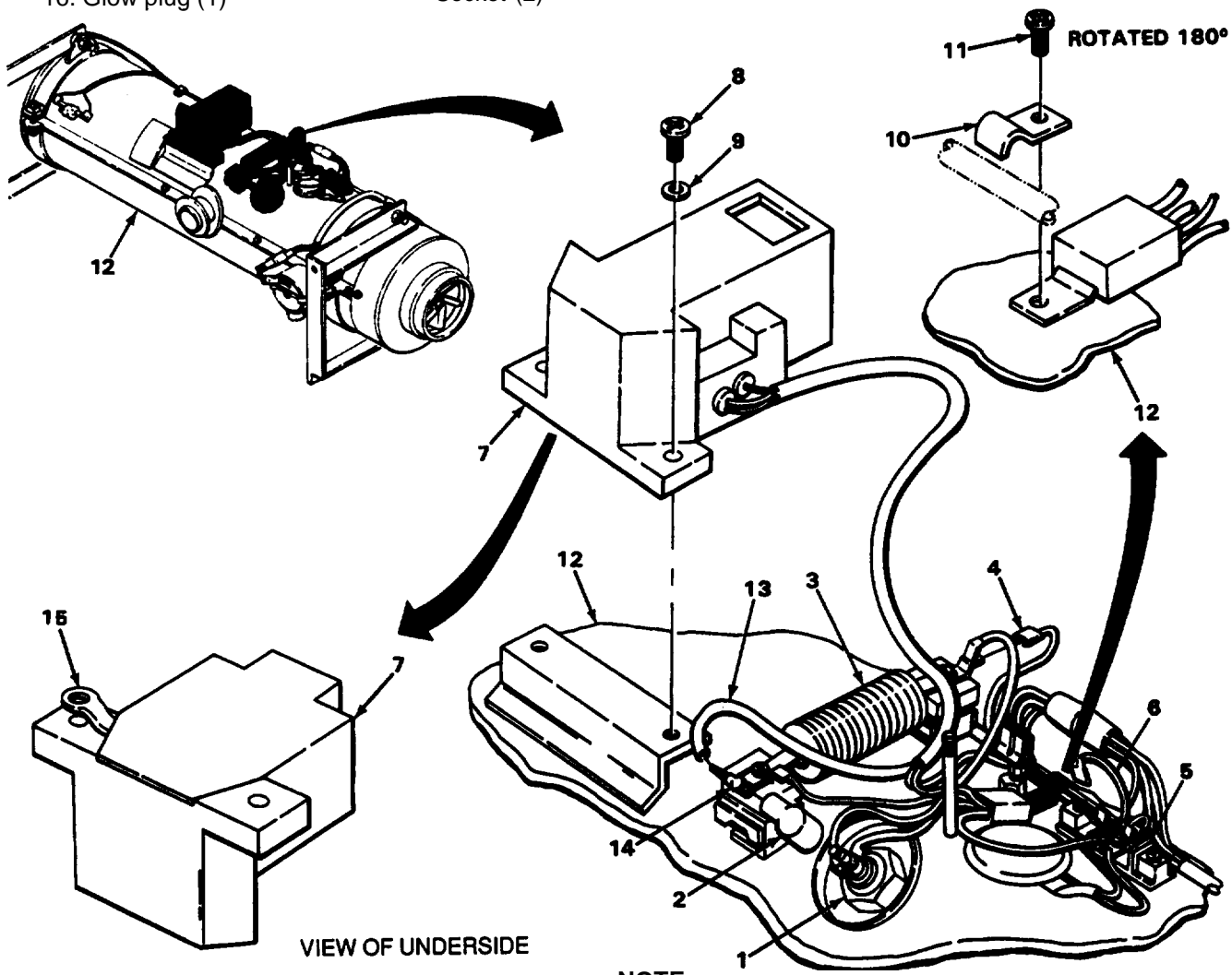

VIEW OF UNDERSIDE

NOTE

FOLLOW-ON MAINTENANCE: Install hood (page 3-135)

TASK ENDS HERE

GLOW PLUG - ESPAR V7S

This task covers:

- a. Removal
 - b. Installation
-

INITIAL SETUP

Tools	Personnel Required
Tool Kit, Mechanics Gen (Item 1, Appendix B) Socket, deep-well, 1/2-inch drive, 22-mm	63G
Materials/Parts	Equipment Condition
Tags, marking (Item 9, Appendix C)	Hood removed (page 3-135)

LOCATION	ITEM	ACTION REMARKS
----------	------	-------------------

REMOVAL

NOTE

Tag all wires and terminals to aid during installation (page 2-3).

1. Glow plug (1)	Three leads (2), (3), and (4)	Remove.
2. Fixed wire resistor (5)	Lead (6)	Remove.
3. Heater (7)	Glow plug (1)	Unscrew and remove.

INSTALLATION

4. Heater (7)	Glow plug (1)	Screw in and tighten.
5. Fixed wire resistor (5)	Lead (6)	Install.

GLOW PLUG - ESPAR V7S - Continued

LOCATION	ITEM	ACTION REMARKS
----------	------	-------------------

INSTALLATION - Continued

6. Glow plug (1)	Three leads (4), (3), and (2)	Install.
------------------	-------------------------------	----------

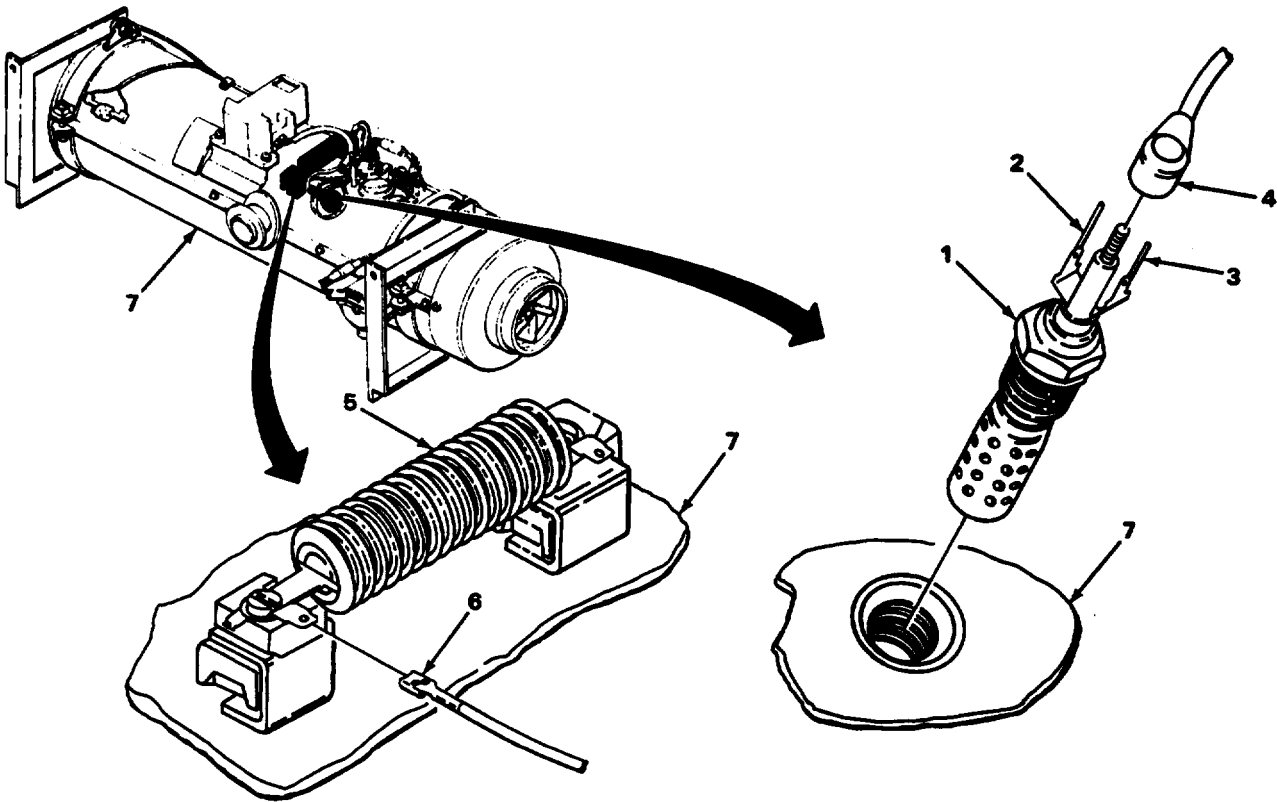

NOTE
FOLLOW-ON MAINTENANCE: Install hood (page 3-135).

TASK ENDS HERE

TEMPERATURE SENSOR-ESPAR V7S

This task covers:

- a. Removal
 - b. Installation
-

INITIAL SETUP

Tools	Personnel Required
Tool Kit, Mechanics Gen (Item 1, Appendix B)	63G
Materials/Parts	
Tags, marking (Item 9, Appendix C)	

LOCATION	ITEM	ACTION REMARKS
----------	------	-------------------

REMOVAL

NOTE

Tag all wires and terminals to aid during installation (page 2-3).

1. Temperature sensor (1)	Connector (2)	Remove.
2. Clamp (3)	Screw (4)	Unscrew part way.

CAUTION

Use care when removing or installing temperature sensor. Quartz rod inside temperature sensor is easily broken.

3. Heater (5)	Temperature sensor (1)	Remove.
4.	Clamp (3)	Remove.

INSTALLATION

5. Heater (5)	Clamp (3)	Slide in position.
---------------	-----------	--------------------

CAUTION

Use care when removing or installing temperature sensor. Quartz rod inside temperature sensor is easily broken.

TEMPERATURE SENSOR - ESPAR V7S - Continued

LOCATION	ITEM	ACTION REMARKS
----------	------	-------------------

INSTALLATION - Continued

- | | | |
|----|---|----------|
| 6. | Temperature sensor (1) | Install. |
| 7. | Clamp (3)
Screw (4) | Tighten. |
| 8. | Temperature sensor (1)
Connector (2) | Install. |

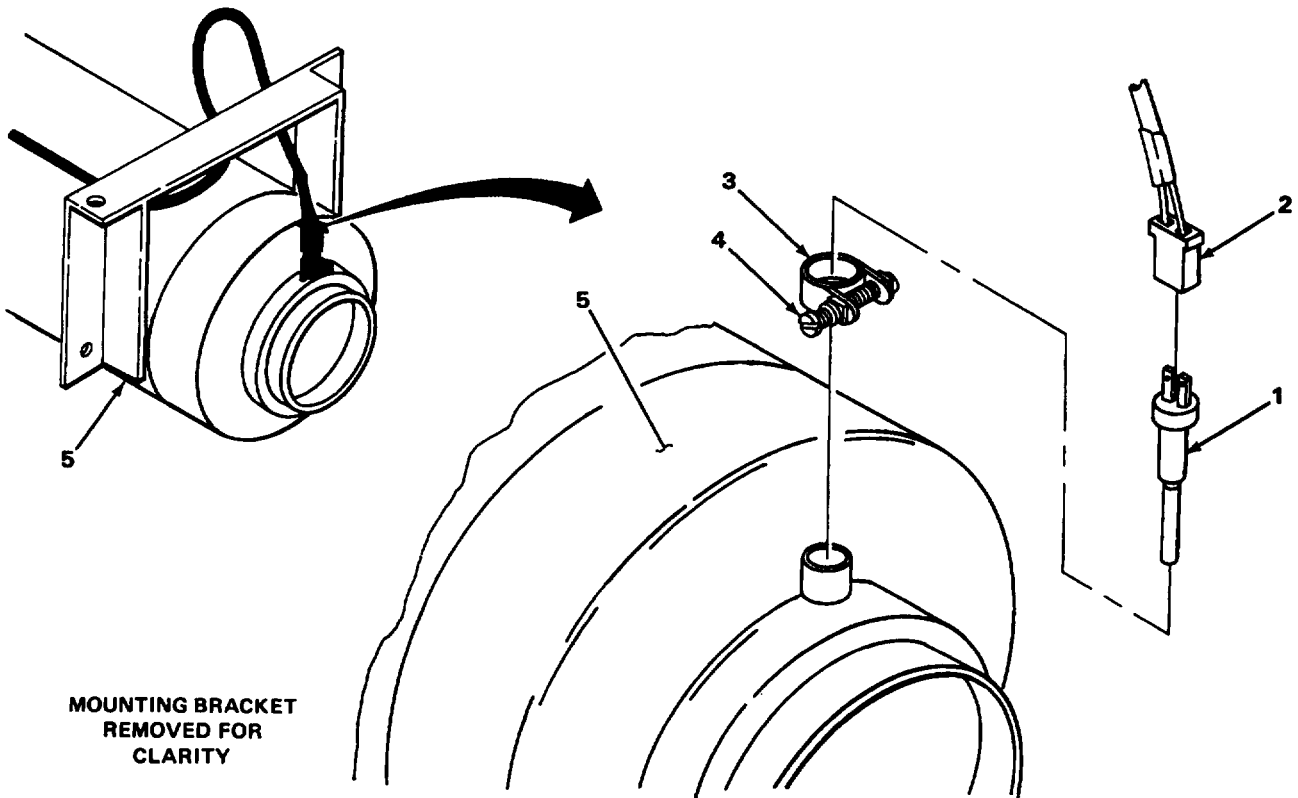

TASK ENDS HERE

THERMOSTATIC SWITCH - ESPAR V7S

This task covers:

- a. Removal
 - b. Installation
-

INITIAL SETUP

Tools	Personnel Required
Tool Kit, Mechanics Gen (Item 1, Appendix B)	63G
Materials/Parts	Equipment Condition
Tags, marking (Item 9, Appendix C)	Hood removed (page 3-135)

LOCATION	ITEM	ACTION	REMARKS
----------	------	--------	---------

REMOVAL

NOTE

Tag all wires and terminals to aid during installation (page 2-3).

1. Connector (1)	Connector (2)	Pull apart.	
2. Heater (3)	Nut (4)	Unscrew and remove.	
3. Thermostatic switch (5)	Connector (2)	a. squeeze switch terminal ends. b. Remove.	

INSTALLATION

4. Thermostatic switch (5)	Connector (2)	a. Bend tabs in terminal ends of switch (4). b. Install switch (4) terminal leads in connector (2).	
5.	Thermostatic switch (5) and nut (4)	a. Install. b. Screw nut (4) in and tighten.	

THERMOSTATIC SWITCH - ESPAR V7S - Continued

LOCATION	ITEM	ACTION	REMARKS
----------	------	--------	---------

INSTALLATION - Continued

6. Connector (1)	Connector (2)	Push together.	
------------------	---------------	----------------	--

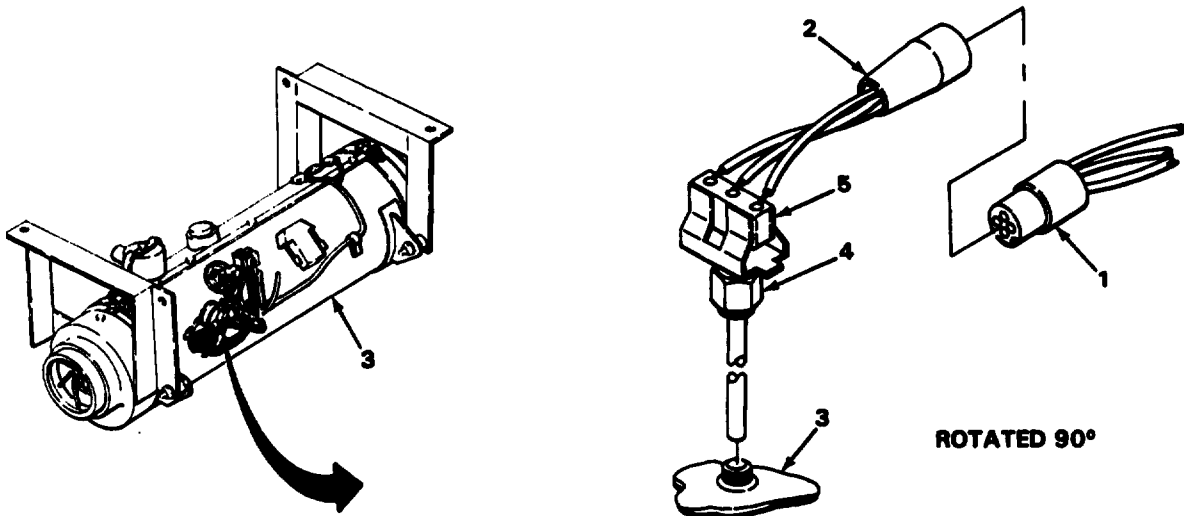

NOTE
 FOLLOW-ON MAINTENANCE: Install hood (page 3-135).

TASK ENDS HERE

FIXED CAPACITOR - ESPAR V7S

This task covers:

- a. Removal
 - b. Installation
-

INITIAL SETUP

Tools	Personnel Required
Tool Kit, Mechanics Gen (Item 1, Appendix B)	63G
Materials/Parts	Equipment Condition
Sealant, silicon (Item 6, Appendix C) Tags, marking (Item 9, Appendix C)	Hood removed (page 3-135)

LOCATION	ITEM	ACTION REMARKS
----------	------	-------------------

REMOVAL

NOTE

Tag all wires and terminals to aid during installation (page 2-3).

1. Fixed resistor (1), glow plug (2), and terminal strip (3)	Four leads (4)	a. Cut off sealant. b. Remove.
2. Heater (5)	Screw (6) and cable clamp (7)	Unscrew and remove.
3.	Fixed capacitor (8)	Remove.

INSTALLATION

4. Heater (5)	Fixed capacitor (8)	Install.
5. Heater (5) and fixed capacitor (8)	Cable clamp (7)	Install.
6. Heater (5) and cable clamp (7)	Screw (6)	Screw in and tighten.

FIXED CAPACITOR - ESPAR V7S - Continued

LOCATION	ITEM	ACTION REMARKS
----------	------	-------------------

INSTALLATION - Continued

7. Fixed resistor (1), glow plug (2), and terminal strip (3)	Four leads (4)	a. Install. b. Apply sealant to terminals and leads.
--	----------------	---

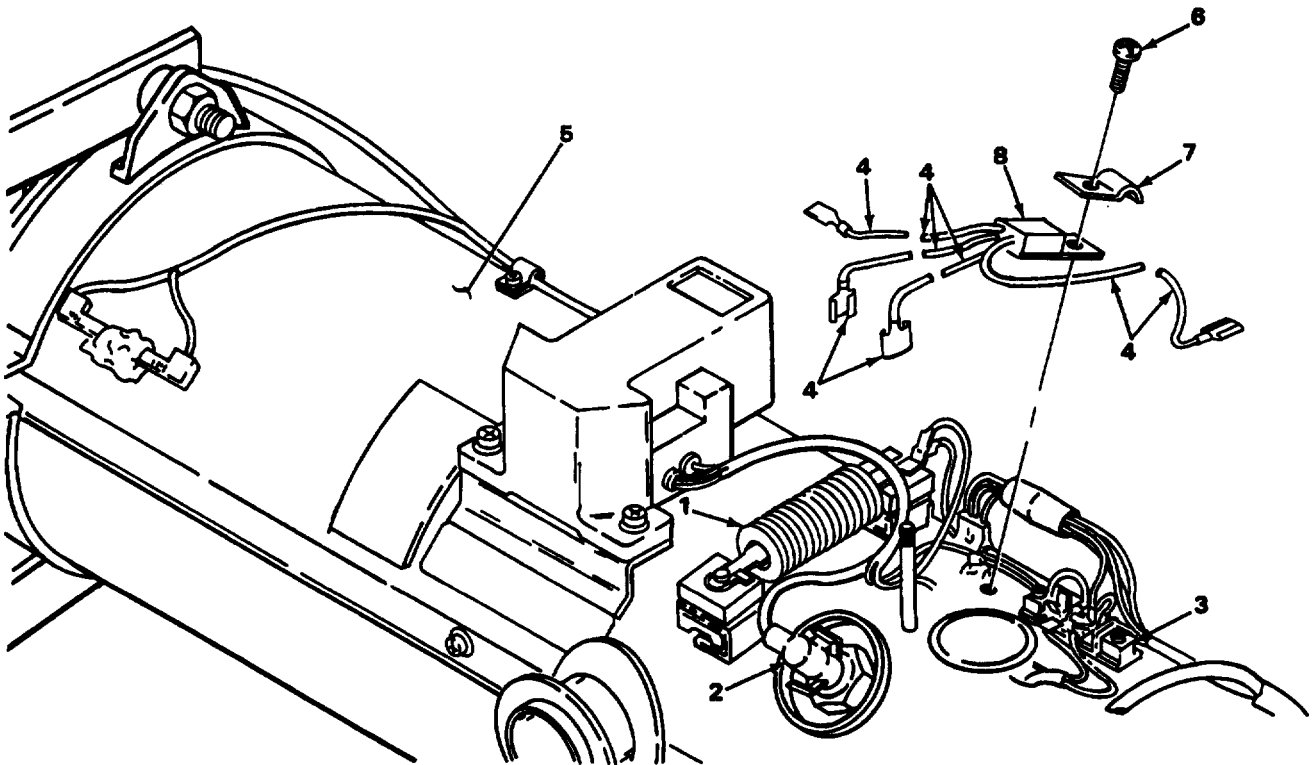

NOTE

FOLLOW-ON MAINTENANCE: Install hood (page 3-135).

TASK ENDS HERE

FIXED WIRE RESISTOR - ESPAR V7S

This task covers:

- a. Removal
- b. Installation

INITIAL SETUP

Tools	Personnel Required
Tool Kit, Mechanics Gen (Item 1, Appendix B)	63G
Materials/Parts	Equipment Condition
Sealant, silicon (Item 6, Appendix C) Tags, marking (Item 9, Appendix C)	Hood removed (page 3-135)

LOCATION	ITEM	ACTION REMARKS
----------	------	-------------------

REMOVAL

NOTE

Tag all wires and terminals to aid during installation (page 2-3).

1. Output terminal (1)	Dual lead (2)	a. Cutoff sealant. b. Remove.
2. Input terminal (3)	Lead (4)	a. Cut off sealant. b. Remove.

NOTE

Brackets should be level when performing steps 3 through 9.

3. Top insulator ((5), bottom insulator (6), and nut (7)	Screw (8), washer (9), and input terminal (3)	a. Hold insulator(5), insulator(6), and nut (7) in place. b. Unscrew and take off screw(8) with washer (9) and terminal (3).
4. Resistor element (10) and bracket (11)	Top insulator (5), bottom insulator (6) and nut (7)	a. Remove. b. Repeat steps 3 and 4a for other end. Resistor element will come off with insulators.

INSTALLATION

5. Bracket (11)	Nut (7), bottom insulator (6) and top insulator (5)	Install.
6. Top insulator (5)	Input terminal (3)	Install.
7. Input terminal (3)	Resistor element (10)	Install.

FIXED WIRE RESISTOR - ESPAR V7S - Continued

LOCATION	ITEM	ACTION REMARKS
INSTALLATION - Continued		
8. Input terminal (3), resistor element (10), and nut (7)	Screw (8) and washer (9)	a. Screw in and tighten. Use care not to overtighten screw. b. Repeat steps 5 through 8a for other side.
9. Input terminal (3)	Lead (4)	a. Install. b. Apply sealant to terminal and lead.
10. Output terminal (1)	Dual lead (2)	a. Install. b. Apply sealant to terminal and lead.

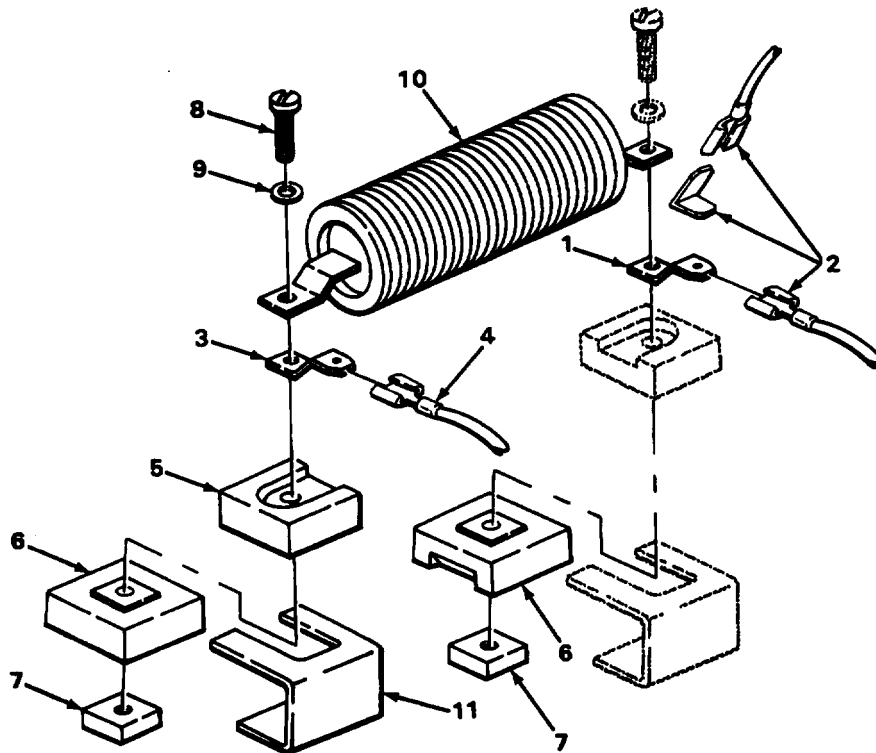

NOTE
FOLLOW-ON MAINTENANCE: Install hood (page 3-135).

TASK ENDS HERE

OVERHEAT SWITCH - ESPAR V7S

This task covers:

- a. Removal
 - b. Installation
-

INITIAL SETUP

Tools	Personnel Required
Tool Kit, Mechanics Gen (Item 1, Appendix B)	63G
Materials/Parts	
Sealant, silicon (Item 6, Appendix C)	
Tags, marking (Item 9, Appendix C)	

LOCATION	ITEM	ACTION REMARKS
----------	------	-------------------

REMOVAL

NOTE
Tag all wires and terminals to aid during installation (page 2-3).

1. Overheat switch (1)	Two leads (2)	a. Cut off sealant. b. Remove.
2.	Two screws (3)	Unscrew and remove.
3. Heater (4)	Overheat switch (1)	Remove.

INSTALLATION

4. Heater (4)	Overheat switch (1)	Install.
5. Overheat switch (1)	Two screws (3)	Screw in and tighten.
6.	Two leads (2)	a. Install. b. Apply sealant to terminals and leads.

OVERHEAT SWITCH - ESPAR V7S - Continued

LOCATION	ITEM	ACTION	REMARKS
----------	------	--------	---------

INSTALLATION - Continued

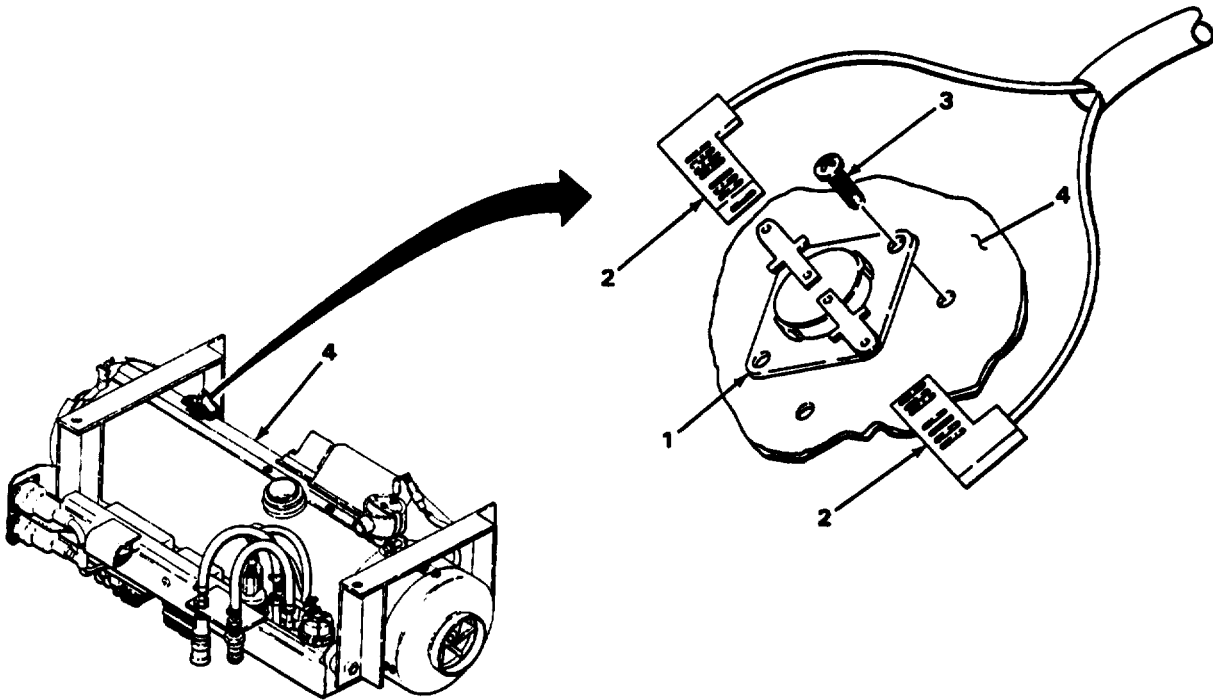

TASK ENDS HERE

TERMINAL BOARD - ESPAR V7S

This task covers:

- a. Removal
- b. Installation

INITIAL SETUP

Tools	Personnel Required
Tool Kit, Mechanics Gen (Item 1, Appendix B)	63G
Materials/Parts	Equipment Condition
Sealant, silicon (Item 6, Appendix C) Tags, marking (Item 9, Appendix C)	Hood removed (page 3-135)

LOCATION	ITEM	ACTION REMARKS
----------	------	-------------------

REMOVAL

NOTE

Tag all wires and terminals to aid during installation (page 2-3).

1. Terminal board (1)	Seven leads (2)	a. Cut off sealant. b. Remove.
2. Terminal board (1) and heater (3)	Two screws (4) and washers (5)	Unscrew and remove.
3. Heater (3)	Terminal board (1)	Remove.

INSTALLATION

4. Heater (3)	Terminal board (1)	Install.
5. Terminal board (1) and heater (3)	Two washers (5) and screws (4)	Screw in and tighten.
6. Terminal board (1)	Seven leads (2)	a. install. b. Apply sealant to terminals and leads.

TERMINAL BOARD - ESPAR V7S - Continued

LOCATION	ITEM	ACTION REMARKS
----------	------	-------------------

INSTALLATION - Continued

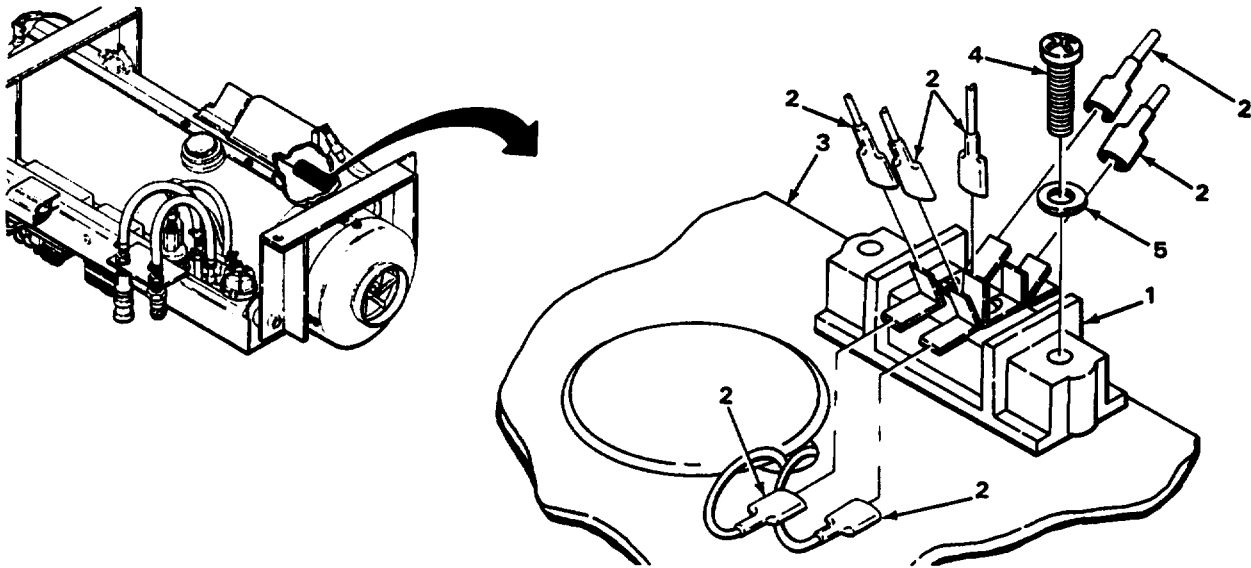

NOTE

FOLLOW-ON MAINTENANCE: Install hood (page 3-135),

TASK ENDS HERE

SOLENOID VALVE-ES-PARV7S

This tasks covers:

- a. Removal
- b. Installation

INITIAL SETUP

Tools	Personnel Required
Tool Kit, Mechanics Gen (Item 1, Appendix B)	63G
Materials/Parts	Equipment Condition
Sealant, silicon (Item 6, Appendix C) Tags, marking (Item 9, Appendix C)	Hood removed (page 3-135)

LOCATION	ITEM	ACTION	REMARKS
----------	------	--------	---------

REMOVAL

1. Connector (1)	Connector (2)	Pull apart.	
2. Clamp (3)	Screw (4)	Unscrew part way.	
3. Heater (5)	Solenoid valve (6) with clamp (3)	Remove.	
4. Solenoid valve (6)	Clamp (3)	Remove.	

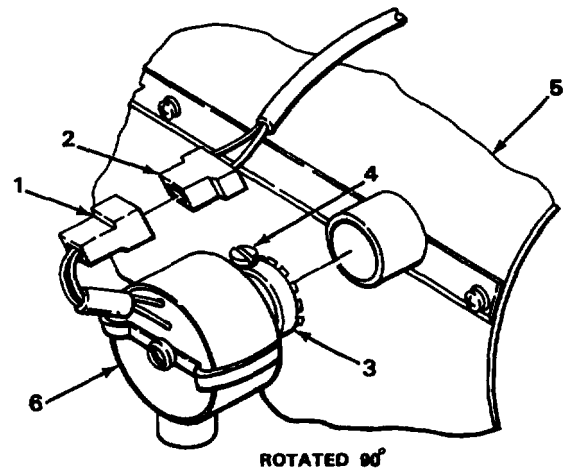
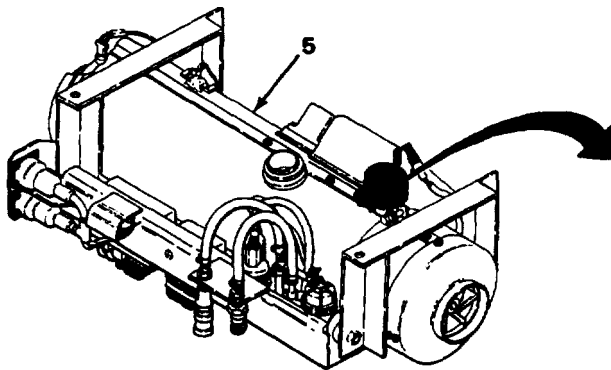

SOLENOID VALVE - ESPAR V7S - Continued

LOCATION	ITEM	ACTION REMARKS
INSTALLATION		
5. Solenoid valve (1)	Clamp (2)	Install.
6. Heater (3)	Solenoid valve (1) with clamp (2)	Install.
7. Clamp (2)	Screw (4)	Screw in and tighten.
8. Connector (5)	Connector (6)	Install.

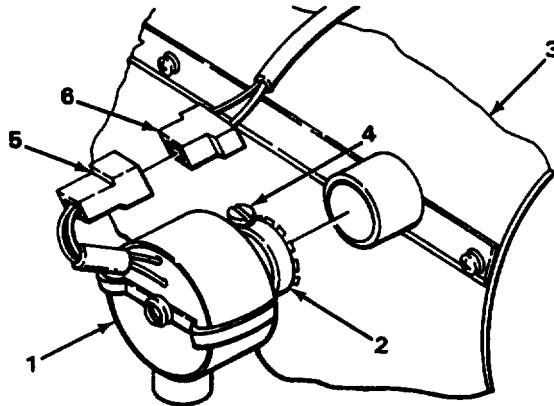

TASK ENDS HERE

WIRING HARNESS - ESPAR V7S

This task covers:

- a. Removal
 - b. Installation
-

INITIAL SETUP

Tools

Tool Kit, Mechanics Gen (Item 1, Appendix B)
 Key, socket-head screw, square drive, 2.5-mm
 (Item 3, Appendix B)

Personnel Required

63G

Materials/Parts

Sealant, silicon (Item 6, Appendix C)
 Tags, marking (Item 9, Appendix C)

Equipment Condition

Hood removed (page 3-135)

LOCATION	ITEM	ACTION REMARKS
----------	------	-------------------

REMOVAL

NOTE

Tag all wires, connectors, and terminals to aid during installation (page 2-3).

1. Three clamps (1) and heater (2)	Three screws (3)	a. Prior to removal, mark position of clamps (1) and heater. b. Unscrew and remove.
2. Heater (2) and wiring harness (4)	Three clamps (1)	Remove.
3. Two clamps (5) and heater (2)	Two screws (6)	a. Prior to removal, mark position of clamps (5) and heater. b. Unscrew and remove.
4. Heater (2) and wiring harness (4)	Two clamps (5)	Remove.
5. Bracket (7) and two connector receptacles (8)	Eight screws (9), nuts (10), and washers (11)	Unscrew and remove.
6. Temperature sensor (1)	Connector (2)	Remove.
7. Overheat switch (3)	Two connectors (4)	a. Cut off sealant. b. Remove.

WIRING HARNESS - ESPAR V7S - Continued

LOCATION	ITEM	ACTION REMARKS
REMOVAL - Continued		
8. Thermostatic switch connector (7)	Connector (6)	Pull apart,
9. Solenoid valve connector (7)	Connector (8)	Pull apart.
10. Terminal board (9)	Two leads (10)	a. Cutoff sealant. b. Remove.
11. Fixed wire resistor terminal (11)	Harness lead (12) with igniter spark generator lead (13)	a. Cutoff sealant. b. Remove.
12. Harness lead (12)	Igniter spark generator lead (13)	Pull apart.
13. Fuel pump (14)	Connector (15)	Remove.
14. Circulating pump (16)	Two connectors (17)	Remove.

WIRING HARNESS - ESPAR V7S - Continued
REMOVAL - Continued

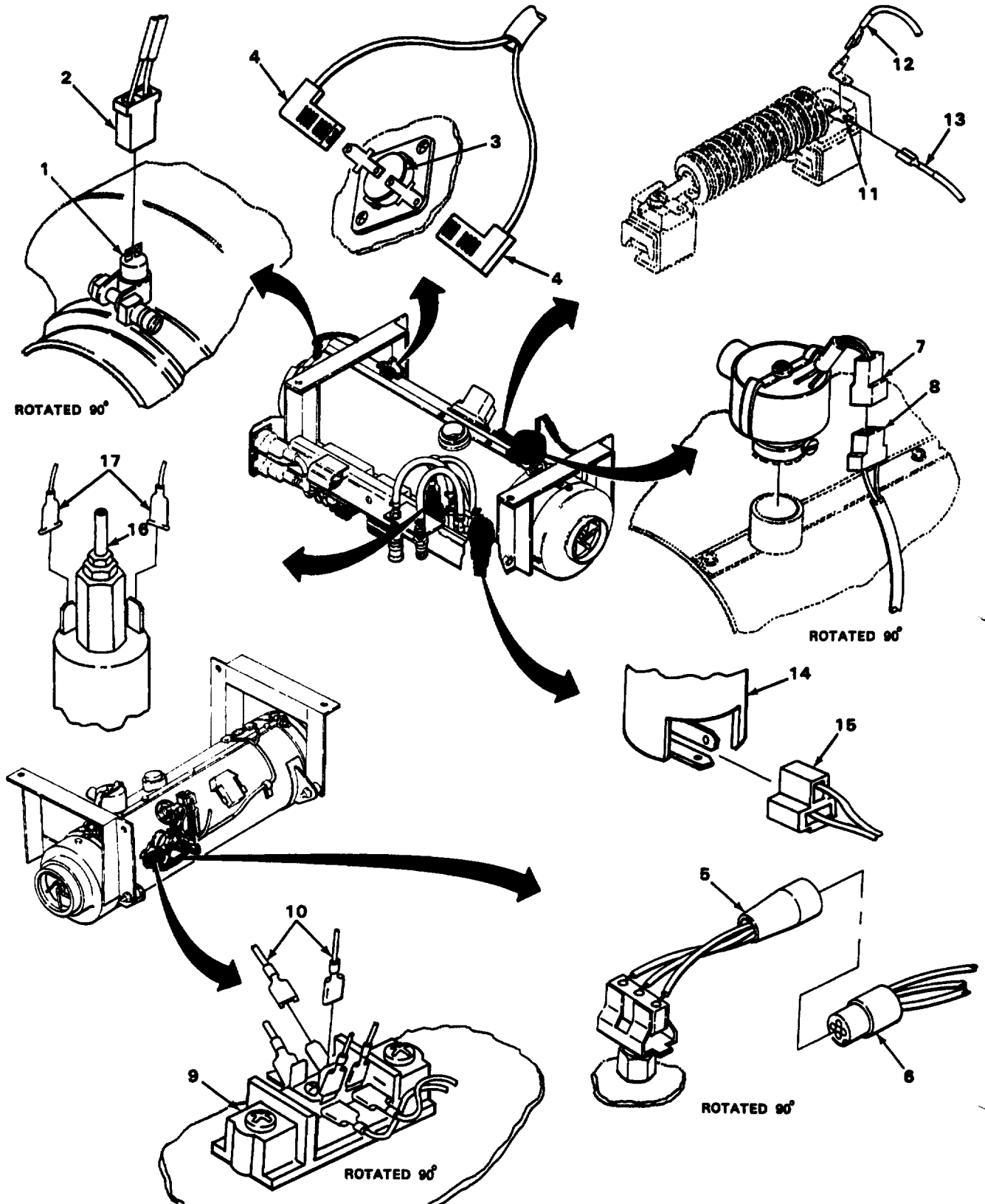

WIRING HARNESS - ESPAR V7S - Continued

LOCATION	ITEM	ACTION	REMARKS
REMOVAL - Continued			
15. Semiconductor (1) and bracket (2)	Nut (3), washer (4), and lead (5)	Unscrew and remove.	
16. Bracket (2)	Semiconductor (1)	Remove.	
17. Heat regulator (6)	Three connectors (7)	Remove.	
18. Impulse switch (8)	Connector (9)	Remove.	
19. Heater (10)	Wiring harness (11)	Remove.	
INSTALLATION			
20. Heater (10)	Wiring harness (11)	Install.	
21. Impulse switch (8)	Connector (9)	Install.	
22. Heat regulator (6)	Three connectors (7)	Install.	
23. Bracket (2)	Semiconductor (1)	Install.	
24. Semiconductor (1) and bracket (2)	Lead (5), washer (4), and nut (3)	Screw in and tighten.	
25. Circulating pump (12)	Two connectors (13)	Install.	
26. Fuel pump (14)	Connector (15)	Install.	
27. Harness lead (16)	Igniter spark generator lead (17)	Push together.	

WIRING HARNESS - ESPAR V7S - Continued

INSTALLATION - Continued

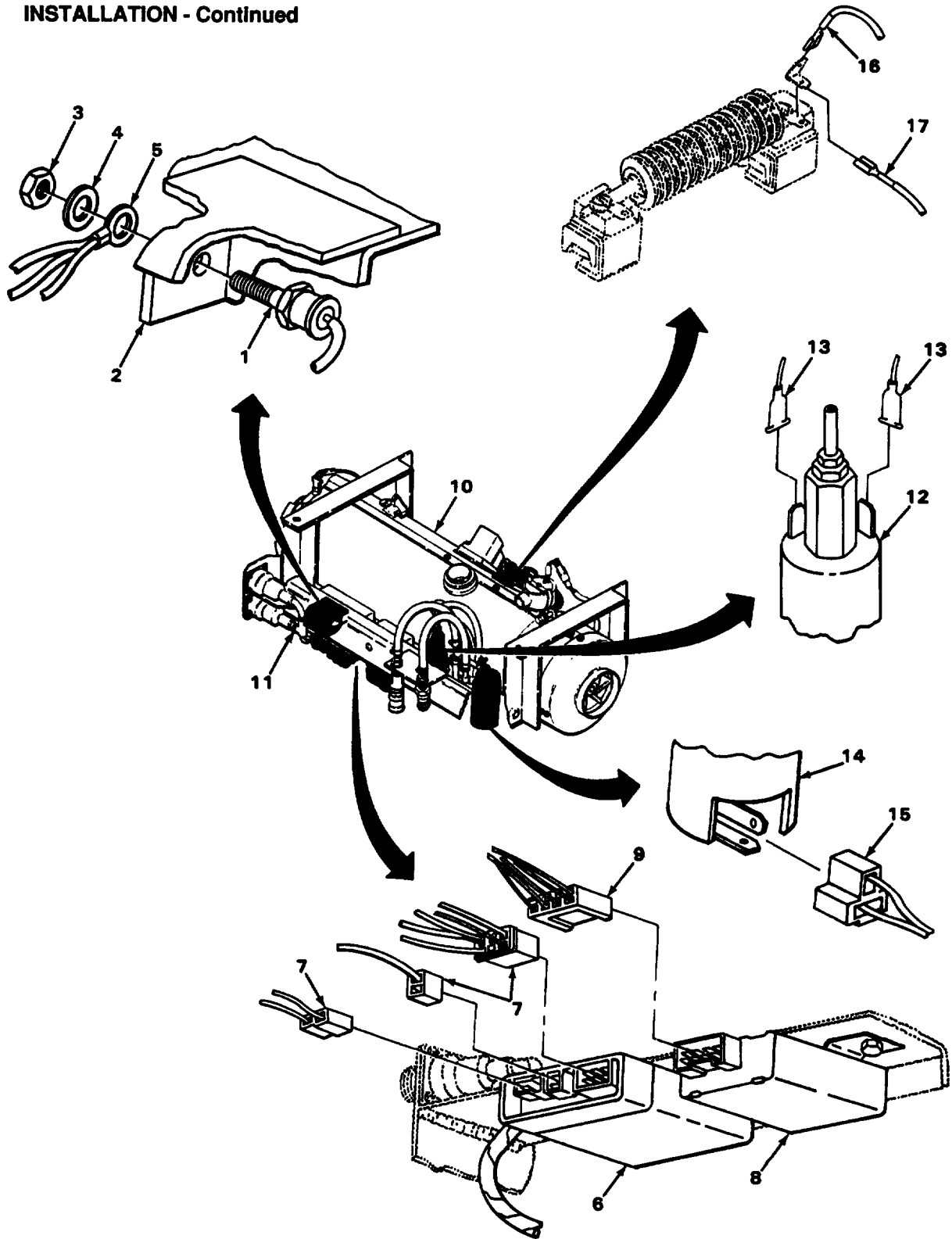

WIRING HARNESS - ESPAR V7S - Continued

LOCATION	ITEM	ACTION REMARKS
INSTALLATION - Continued		
28. Fixed wire resistor terminal (1)	Dual lead (2)	a. Install. b. Apply sealant to terminals and leads.
29. Terminal board (3)	Two leads (4)	a. Install. b. Apply sealant to terminals and leads.
30. Solenoid valve connector (5)	Connector (6)	Push together,
31. Thermostatic switch connector (7)	Connector (8)	Push together.
32. Overheat switch (9)	Two connectors (10)	a. Install. b. Apply sealant to terminals and leads.
33. Temperature sensor (11)	Connector (12)	Install.
34. Bracket (13) and two connector receptacles (14)	Eight washers (15), screws (16), and nuts (17)	Screw in and tighten.
35. Heater (18) and wiring harness (19)	Two clamps (20)	Install, noting positions marked during removal.
36. Two clamps (20) and heater (18)	Two screws (21)	Screw in and tighten.
37. Heater (18) and wiring harness (19)	Three clamps (22)	Install, noting positions marked during removal.
38. Three clamps (22) and heater (18)	Three screws (23)	Screw in and tighten.

WIRING HARNESS - ESPAR V7S - Continued

INSTALLATION - Continued

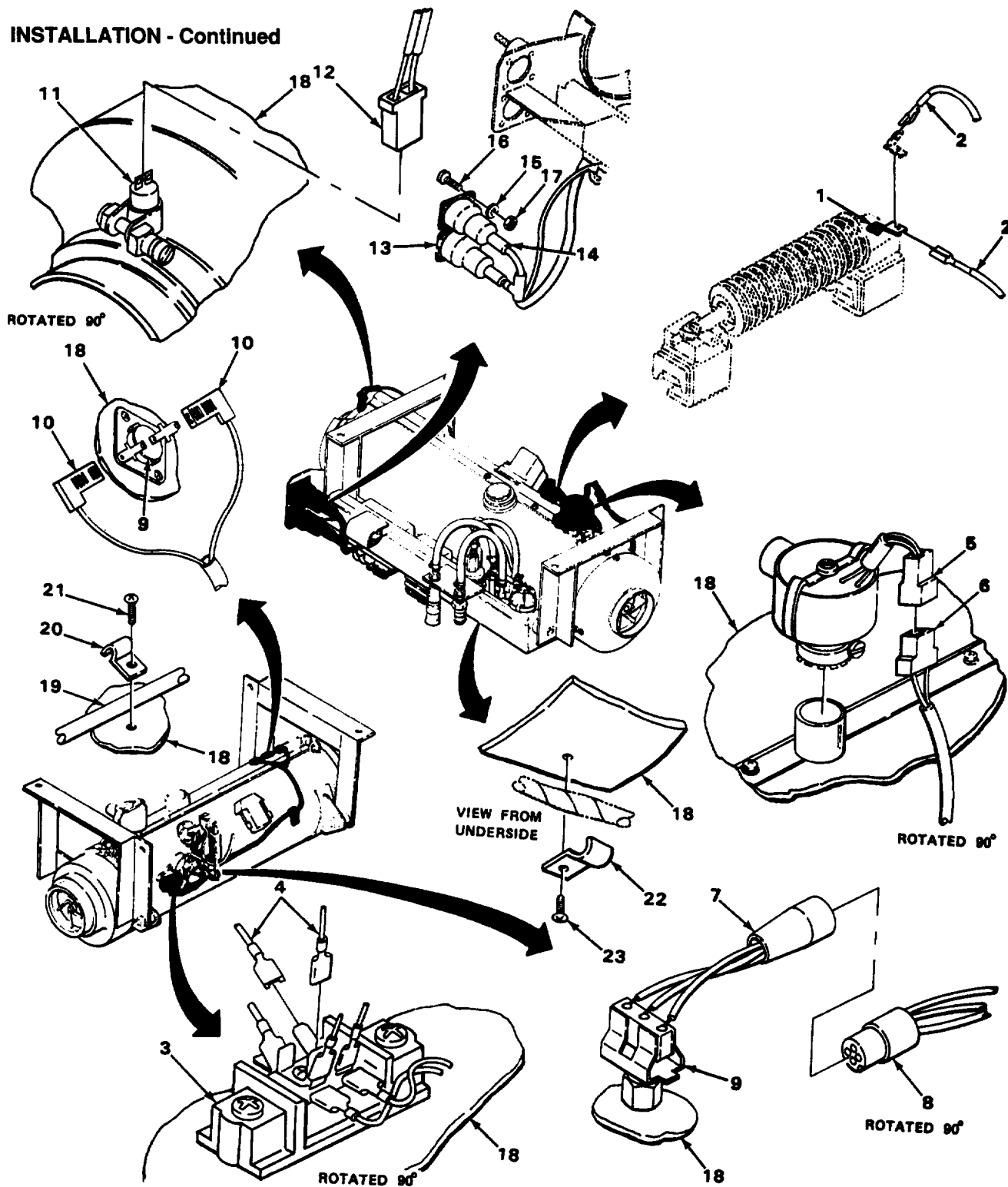

NOTE
FOLLOW-ON MAINTENANCE: Install hood (page 3-135).

TASK ENDS HERE

WIRING HARNESS REPAIR - ESPAR V7S

This task covers:

- a. Connector and Terminal Removal
 - b. Connector and Terminal Installation
-

INITIAL SETUP

Tools		Personnel Required
Tool Kit, Mechanics Gen (Item 1, Appendix B)		63G
Stripper, wire		
Tool, crimping		
Materials/Parts		
Terminal wire		

LOCATION	ITEM	ACTION REMARKS
----------	------	-------------------

NOTE

Wiring harness repair consists of connector and terminal removal and installation. All connectors and terminals are removed and installed the same way. The number of terminals in connectors or sizes of terminals and connectors may vary. This is a representative task.

CONNECTOR AND TERMINAL REMOVAL

1. Connector (1)	Terminal (2) and wire (3)	a. Straighten terminal (2) tab. b. Remove.
2. Wire (3)	Terminal (2)	a. Cut off as close to terminal (2) as possible. b. Discard.

CONNECTOR AND TERMINAL INSTALLATION

3.	Wire (3)	a. Strip approximately 1/4-inch of insulation off wire (3) end. b. Twist strands of wire to make sure they will all go into new terminal (2).
----	----------	--

WIRING HARNESS REPAIR - ESPAR V7S - Continued

LOCATION	ITEM	ACTION	REMARKS
----------	------	--------	---------

CONNECTOR AND TERMINAL INSTALLATION - Continued

4. Wire (3)	New terminal (2)	a. Install wire (3).	b. Crimp onto wire.
5. Connector (1)	Terminal (2) with wire (3)	a. Bend tab on terminal (2).	b. Install.

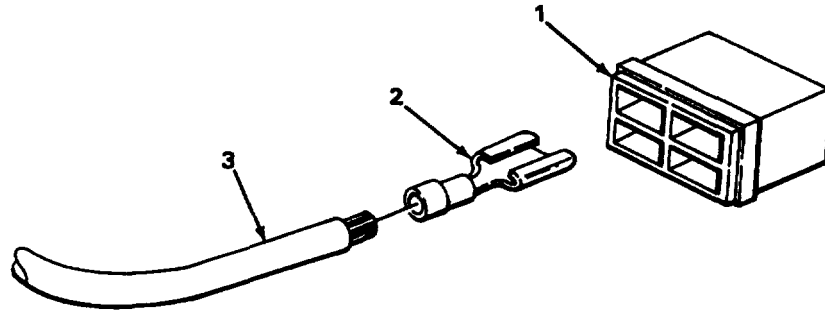

TASK ENDS HERE

MOUNTING ASSEMBLY - ESPAR V7S

This task covers:

- a. Removal
 - b. Installation
-

INITIAL SETUP

Tools	Personnel Required
Tool Kit, Mechanics Gen (Item 1, Appendix B)	63G

Materials/Parts

Tags, marking (Item 9, Appendix C)

LOCATION	ITEM	ACTION REMARKS
----------	------	-------------------

REMOVAL

NOTE

Tag all wires, terminals, and connectors to aid during installation (page 2-3).

1. Temperature sensor (1)	Connector (2)	Remove.
2. Two mounts (3) and bracket (4)	Two nuts (5) and washers (6)	Unscrew and remove.
3. Two mounts (3)	Mounting bracket (4)	Remove.
4. Clamp (7)	Screw (8)	Unscrew and remove.
5. Bracket (9)	Clamp (7)	Remove.
6. Bracket (9) and two mounts (3)	Two nuts (1 O) and washers(11)	Unscrew and remove.
7. Bracket (9)	Two mounts (3)	a. Remove. b. Repeat steps 2 through 7a for other side.
8. Bracket (9) and two connector receptacles (12)	Eight screws (13), nuts (14), and washers (15)	Unscrew and remove.
9. Bracket (9)	Two connector receptacles (12)	Remove.
10. Semiconductor (16) and lead (17)	Nut (18) and washer (19)	Unscrew and remove.
11. Bracket (9)	Semiconductor (16) and lead (17)	Remove.
12. Two clamps (20)	Two screws (21)	Unscrew and remove.
13. Circulating pump (22)	Two hoses (23) with clamps (20)	Remove.
14.	Two connectors (24)	Remove.

MOUNTING ASSEMBLY - ESPAR V7S - Continued

LOCATION	ITEM	ACTION	REMARKS
----------	------	--------	---------

REMOVAL - Continued

15. Fuel pump (25) Connector (26) Remove.

16. Pulse generator (27) and control box (28) Four connectors (29) Remove.

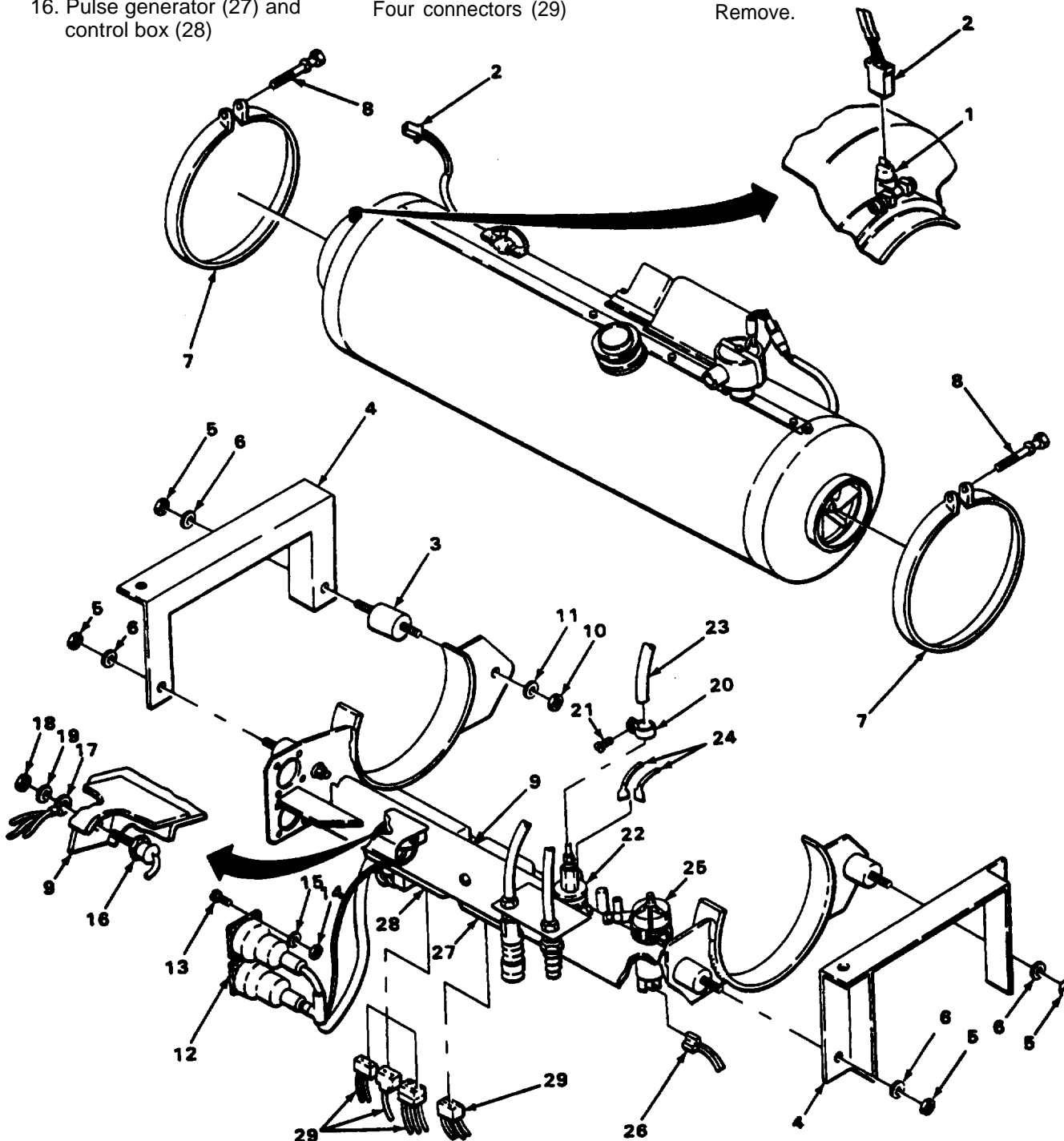

MOUNTING ASSEMBLY - ESPAR V7S - Continued

LOCATION	ITEM	ACTION REMARKS
REMOVAL - Continued		
17. Bracket (1)	Heater (2)	Remove,
18. Bracket (1), pulse generator (3), and control box (4)	Three screws (5), nuts (6), and washers (7)	Unscrew and remove.
19. Bracket (1)	Pulse generator and control box (4)	Remove.
20. Two clamps (8)	Two screws (9)	Unscrew and remove.
21. Two adapters (1 O)	Two hoses (11) with clamps (8)	Remove.
22.	Two nuts (12) and washers (13)	Unscrew and remove.
23. Bracket (1)	Two adapters (1 O)	Remove.
24. Clamp (14)	Screw (15)	Unscrew until rings come out.
25.	Circulating pump (16)	Remove.
26. Bracket (1)	Clamp (14)	a. Remove. b. Repeat steps 24 through 26a for fuel pump (17).
INSTALLATION		
27. Bracket (1)	Clamp (14)	install.
28. Clamp (14)	Circulating pump (16)	Install.
29.	Screw (15)	a. install ring. b. Screw in and tighten. c. Repeat steps 27 through 29b for fuel pump (17).
30. Bracket (1)	Two adapters (10)	Install.
31.	Two hoses (11) with clamps (8)	Install.
32. Two clamps (8)	Two screws (9)	Screw in and tighten.
33. Bracket (1)	Pulse generator and control box	install.

MOUNTING ASSEMBLY - ESPAR V7S - Continued

LOCATION	ITEM	ACTION REMARKS
----------	------	-------------------

INSTALLATION - Continued

34. Bracket (1), pulse generator (3), and control box (4)	Three washers (7), screws (5), and nuts (6)	Screw in and tighten.
---	---	-----------------------

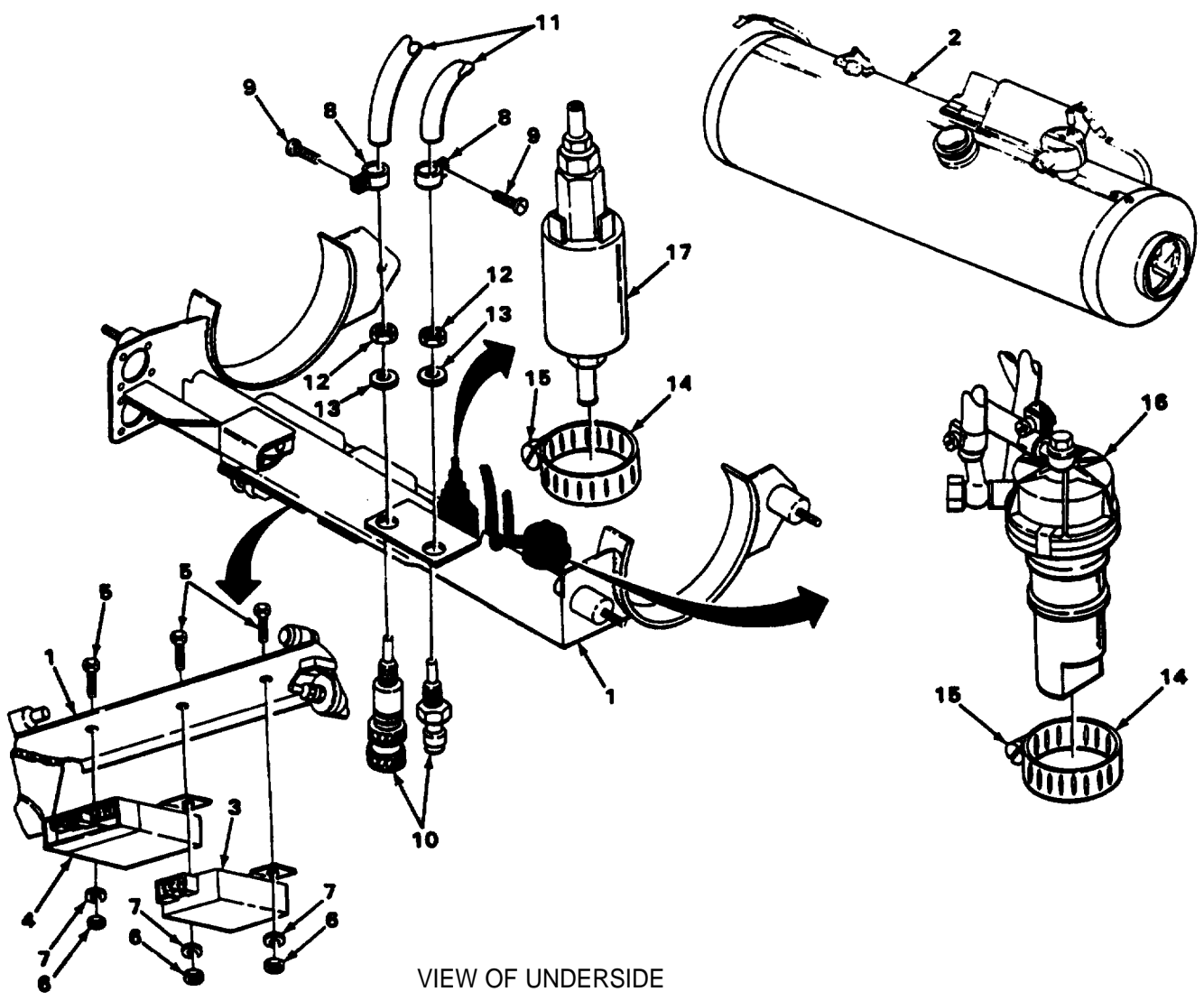

MOUNTING ASSEMBLY - ESPAR V7S - Continued

LOCATION	ITEM	ACTION REMARKS
INSTALLATION - Continued		
35. Bracket (1)	Heater (2)	Install.
36. Circulating pump (3)	Connector (4)	Install.
37. Fuel pump (5)	Two connectors (6)	Install.
38.	Two hoses (7) with clamps (8)	Install.
39. Two clamps (8)	Two screws (9)	Screw in and tighten.
40. Bracket (1)	Semiconductor (10) and lead (11)	Install.
41. Semiconductor (10) and lead (11)	Nut (12) and washer (13)	Screw in and tighten.
42. Bracket (1)	Two connector receptacles (14)	Install.
43. Bracket (1) and two connector receptacles (14)	Eight washers (15), screws (16), and nuts (17)	Screw in and tighten.
44. Bracket (1)	Two mounts (18)	Install.
45. Bracket (1) and two mounts (18)	Two washers (19) and nuts (20)	Screw in and tighten.
46. Bracket (1)	Clamp (21)	Install.
47. Clamp (21)	Screw (22)	Screw in and tighten.
48. Two mounts (18)	Mounting bracket (23)	Install.
49. Two mounts (18) and bracket (23)	Two washers (24) and nuts (25)	a. Screw in and tighten. b. Repeat steps 45 through 50a for the other side.
50. Temperature sensor (26)	Connector (27)	Install.

MOUNTING ASSEMBLY - ESPAR V7S - Continued

LOCATION	ITEM	ACTION	REMARKS
----------	------	--------	---------

INSTALLATION - Continued

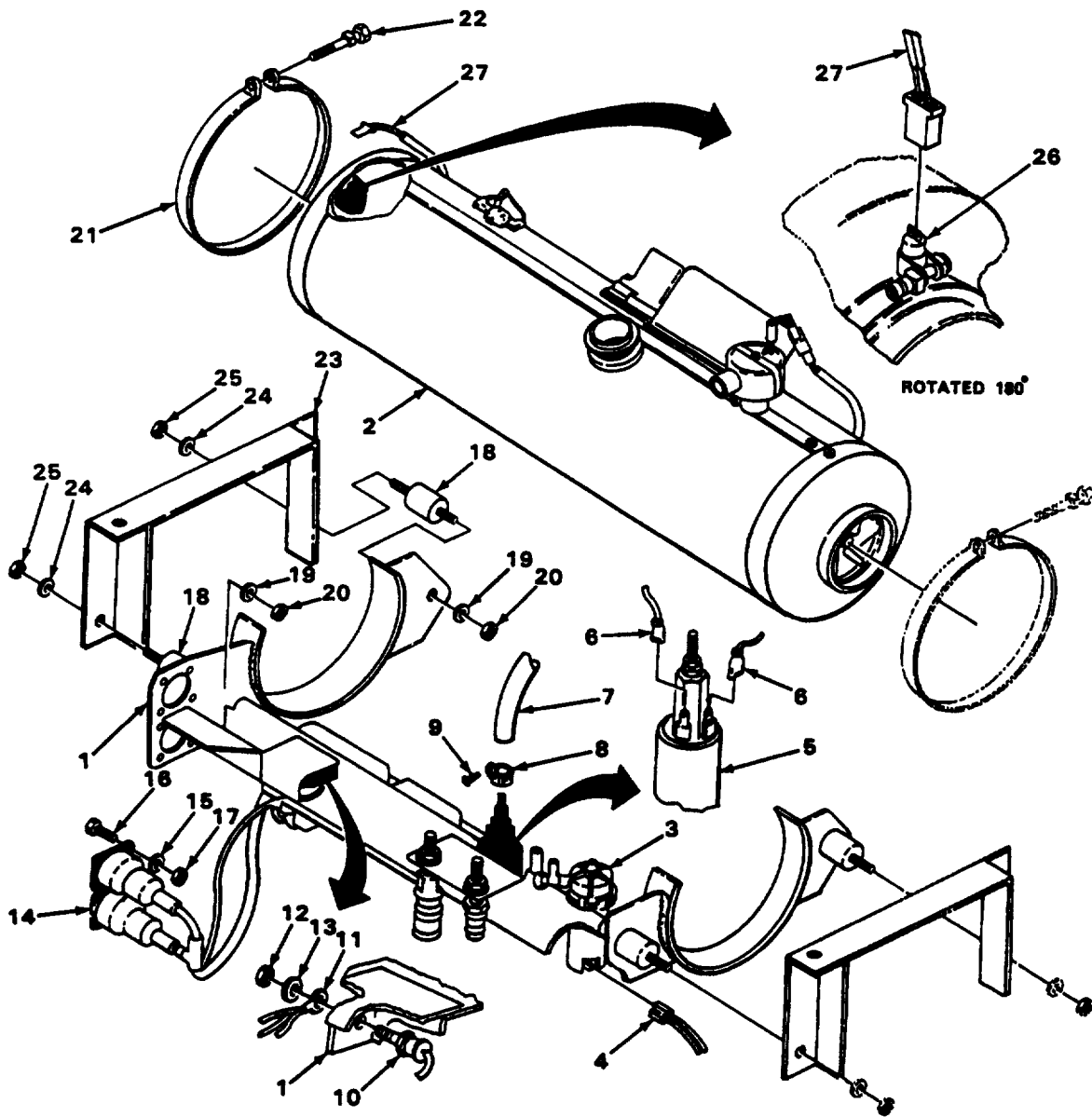

TASK ENDS HERE

FUEL LINES AND FITTINGS - ESPAR V7S

This task covers:

- a. Removal
 - b. Installation
-

INITIAL SETUP

Tools	Personnel Required
Tool Kit, Mechanics Gen (Item 1, Appendix B)	63G

Materials/Parts

Pan, drain
Tags, marking (Item 9, Appendix C)

LOCATION	ITEM	ACTION REMARKS
----------	------	-------------------

REMOVAL

WARNING

The fuels this heater runs on are very explosive. Do not smoke or allow open flame nearby when performing these adjustments. serious Injury or death to personnel could result if this warning is not observed.

NOTE

Tag all wires, connectors, and terminals to aid during installation (page 2-3).

1. Two clamps (1)	Two screws (2)	a. Place drain pan under hoses and fittings. b. Unscrew partway.
2. Adapter (3) and ring (4)	Hose (5) with two clamps (1)	Twist and remove. Clamp screws may have to be unscrewed and taken out.
3. Hose (5)	Two clamps (1)	a. Remove. b. Repeat steps 1 through 3a for hose (6) from adapter (7) to tee (8), for hose (9) from fuel pump (1 O) to tee (8), and for hose (11) from ring (12) to tee (8).
4. Two clamps (13)	Two screws (14)	Unscrew part way.
5. Fuel pump (10) and inlet tube (15)	Hose (16), two clamps (13)	Twist and remove.
6. Hose (16)	Two clamps (13)	Remove.

FUEL LINES AND FITTINGS - ESPAR V7S - Continued

LOCATION	ITEM	ACTION REMARKS
----------	------	-------------------

REMOVAL - Continued

7. Circulating pump (17)	Screw (18) with ring (12) and two washers (19)	Unscrew and remove.
--------------------------	--	---------------------

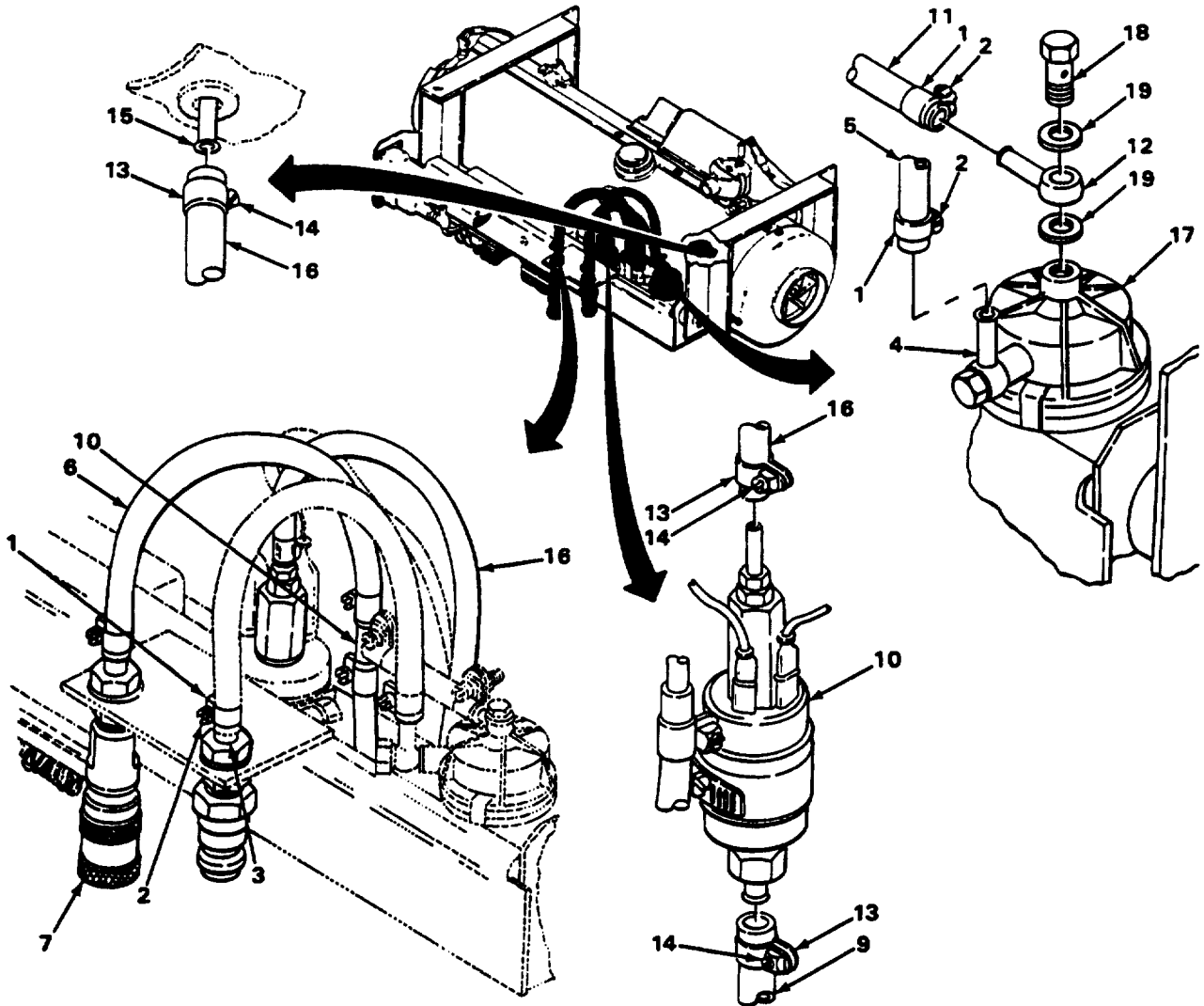

FUEL LINES AND FITTINGS - ESPAR V7S - Continued

LOCATION	ITEM	ACTION REMARKS
REMOVAL - Continued		
8. Screw (1)	Ring (2) and two washers (3)	a. Remove and separate. b. Repeat steps 7 and 8a for screw (4).
9. Adapter (5)	Coupling (6)	a. Unscrew and remove. b. Repeat step 9a for coupling (7).
10. Bracket (8) and adapter (5)	Nut (9) and washer (10)	Unscrew and remove.
11. Bracket (8)	Adapter (5)	a. Remove. b. Repeat steps 10 and 11a for adapter (11).

INSTALLATION

WARNING

The fuels this heater runs on are very explosive. Do not smoke or allow open flame nearby when performing these adjustments. Serious injury or death to personnel could result if this warning is not observed.

NOTE

Hoses are manufactured from bulk material. See Appendix E for new hoses.

12. Bracket (8)	Adapter (5)	Install.
13. Bracket (8) and adapter (5)	Washer (10) and nut (9)	a. Screw in and tighten. b. Repeat steps 12 and 13a for adapter (11).
14. Adapter (5)	Coupling (6)	a. Screw in and tighten. b, Repeat step 14a for coupling (7).
15. Screw (1)	Ring (2) and two washers (3)	Install.
16. Circulating pump (12)	Screw (1) with ring (2) and two washers (3)	a. Screw in and tighten. b. Repeat steps 15 and 16a for screw (4).
17. Hose (13)	Two clamps (14)	Install.
18. Fuel pump (15) and inlet tube (16)	Hose (13) with two clamps (14)	Twist into position.

FUEL LINES AND FITTINGS - ESPAR-continued

LOCATION	ITEM	ACTION	REMARKS
----------	------	--------	---------

INSTALLATION - Continued

19. Two clamps (14)	Two screws (17)	Screw in and tighten.	
---------------------	-----------------	-----------------------	--

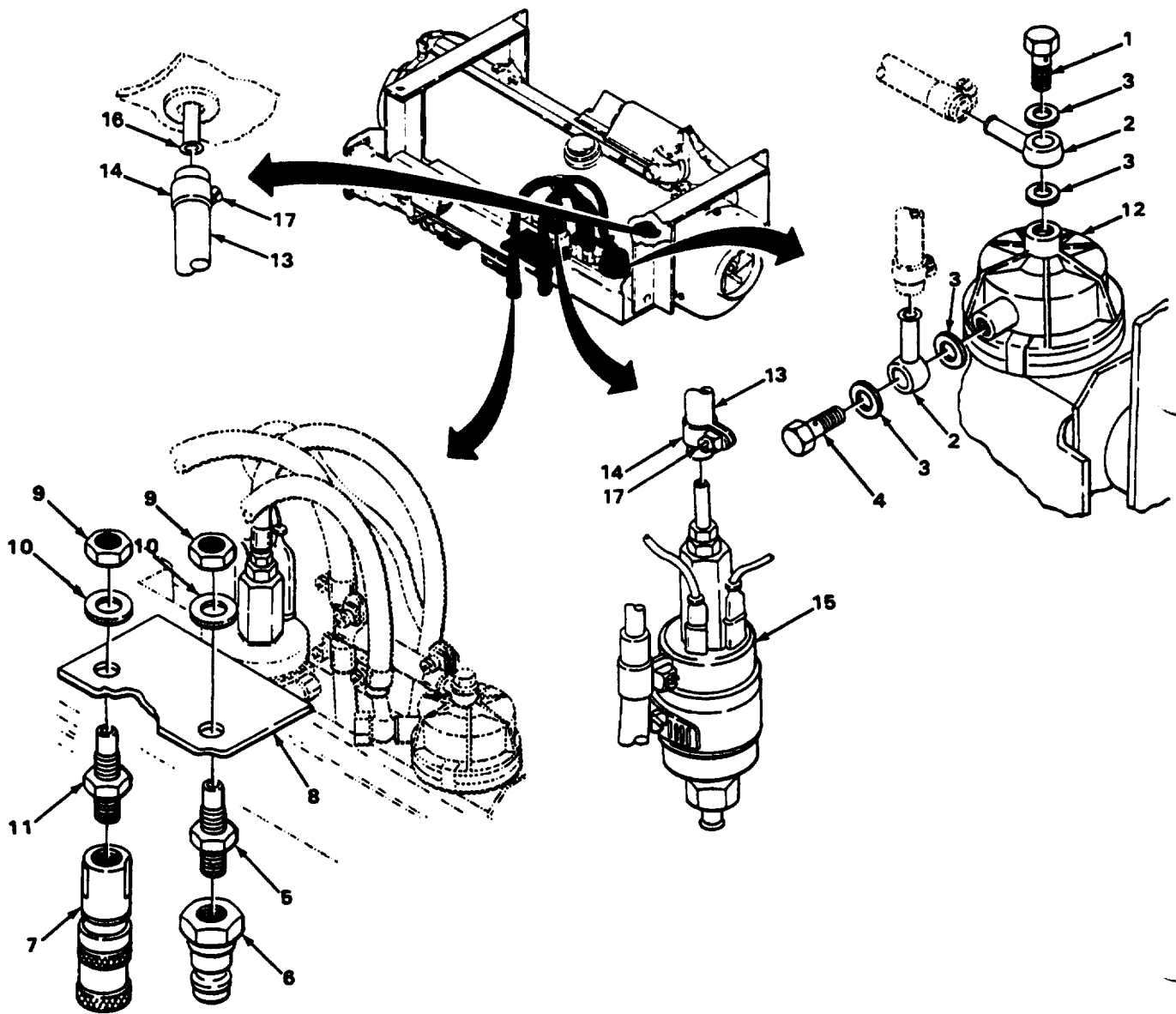

FUEL LINES AND FITTINGS - ESPAR V7S - Continued

LOCATION	ITEM	ACTION REMARKS
----------	------	-------------------

INSTALLATION - Continued

20. Hose (1)	Two clamps (2)	Install.
21. Adapter (3) and ring (4)	Hose (1) with two clamps (2)	Twist into position. Clamp screws may have to be unscrewed and taken out.
22. Two clamps (2)	Two screws (5)	Screw in and tighten. Repeat steps 20 through 22a for hose (6) from tee (7) to ring (8), for hose (9) from tee (7) to fuel pump (10), and for hose (11) from tee (7) to adapter (12). Discard fuel in drain pan.

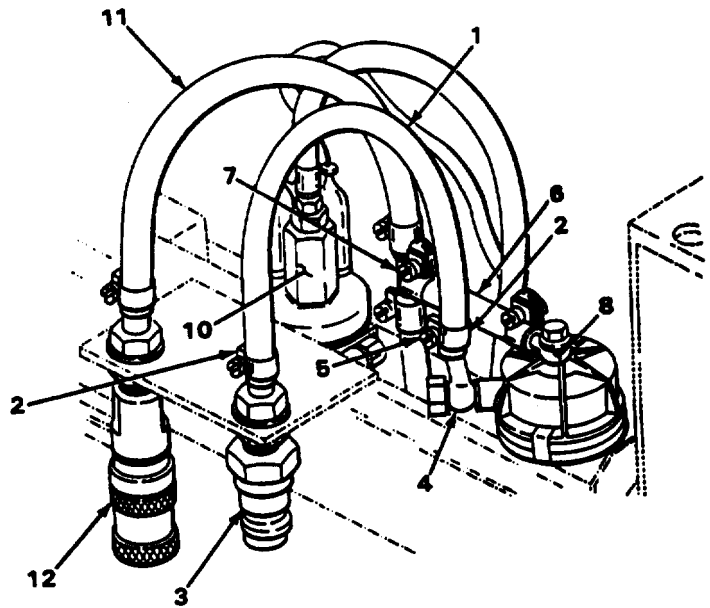
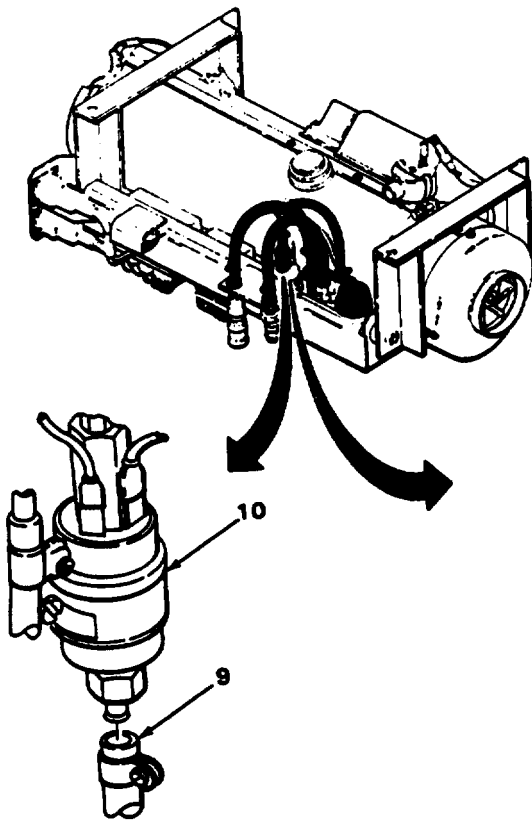

TASK ENDS HERE

CIRCULATING PUMP - ESPAR V7S

This task covers:

- a. Removal
 - b. Installation
-

INITIAL SETUP

Tools	Personnel Required
Tool Kit, Mechanics Gen (Item 1, Appendix B)	63G
Materials/Parts	
Pan, drain Tags, marking (Item 9, Appendix C)	

LOCATION	ITEM	ACTION REMARKS
----------	------	-------------------

REMOVAL

WARNING

Fuel burns easily. Fumes are explosive. Do not smoke or allow open flame nearby when working. Failure to observe these precautions could cause serious injury or death.

NOTE

Tag all wires, connectors, and terminals to aid during installation (page 2-3).

1. Clamp (1)	Screw (2)	Unscrew part way.
2. Circulating pump (3)	Two fuel passage bolts (4) with rings (5) and four washers (6)	a. Place drain pan under pump (3). b. Unscrew and remove.
3. Clamp (7)	Screw (8)	Unscrew until clamp (7) ring comes out.
4.	Circulating pump (3) with cushion (9)	Remove.
5. Circulating pump (3)	Connector (10)	Remove.
6. Mounting bracket(11)	Clamp (7)	Remove.

INSTALLATION

7. Mounting bracket(11)	Clamp (7)	Install. if clamp was replaced, screw on new clamp will have to be unscrewed until ring comes out.
8. Circulating pump (3)	Connector (9)	Install.

CIRCULATING PUMP - ESPAR V7S - Continued

LOCATION	ITEM	ACTION	REMARKS
REMOVAL - Continued			
9.	Connector (10)	Install.	
10.	Clamp (7)	Install.	
11.	Screw (8)	a. Install clamp (7) ring in position. b. Screw in and tighten.	
12.	Circulating pump (3)	a. Screw in and tighten. b. Discard fuel in drain pan.	
13.	Clamp (1)	Screw in and tighten.	

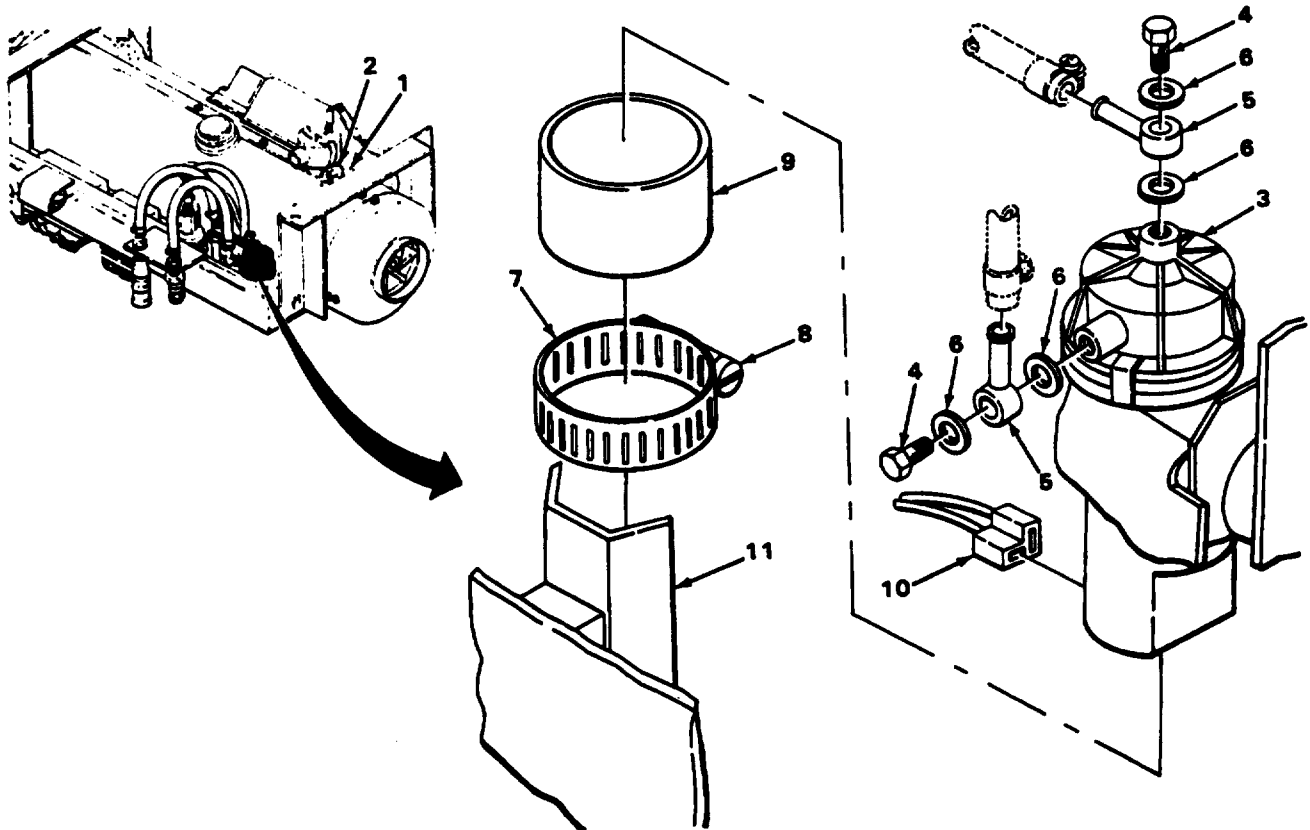

TASK ENDS HERE

FUEL PUMP - ESPAR V7S

This task covers:

- a. Removal
 - b. Installation
-

INITIAL SETUP

Tools	Personnel Required
Tool Kit, Mechanics Gen (Item 1, Appendix B)	63G
Materials/Parts	
Pan, drain	

LOCATION	ITEM	ACTION	REMARKS
----------	------	--------	---------

REMOVAL

1. Clamp (1)	Screw (2)	a. Position drain pan to catch fuel. b. Unscrew partway.	
--------------	-----------	---	--

WARNING

Fuel burns easily. Fumes are explosive. Do not smoke or allow open flame nearby when working. Failure to observe these precautions could cause serious injury or death.

2. Clamp (3)	Screw (4)	Unscrew part way.	
3. Fuel pump (5)	Inlet hose (6) with clamp (3)	Remove.	
4. Clamp (7)	Screw (8)	Unscrew part way.	
5. Fuel pump (5)	Outlet hose (9) with clamp (7)	Remove.	
6. Clamp (10)	Screw (11)	Unscrew until ring comes out.	
7.	Fuel pump (5) and cushion (12)	Remove.	
8.	Two connectors (13)	Remove.	
9. Fuel pump (5)	Cushion (12)	Remove.	
10. Mounting bracket (14)	Clamp (10)	Remove.	

FUEL PUMP - ESPAR V7S - Continued

LOCATION	ITEM	ACTION	REMARKS
INSTALLATION			
11. Mounting bracket (14)	Clamp (10)	Install.	If clamp was replaced, screw-on new clamp will have to be loosened until ring comes out.
12. Fuel pump (5)	Cushion (12)	Install.	

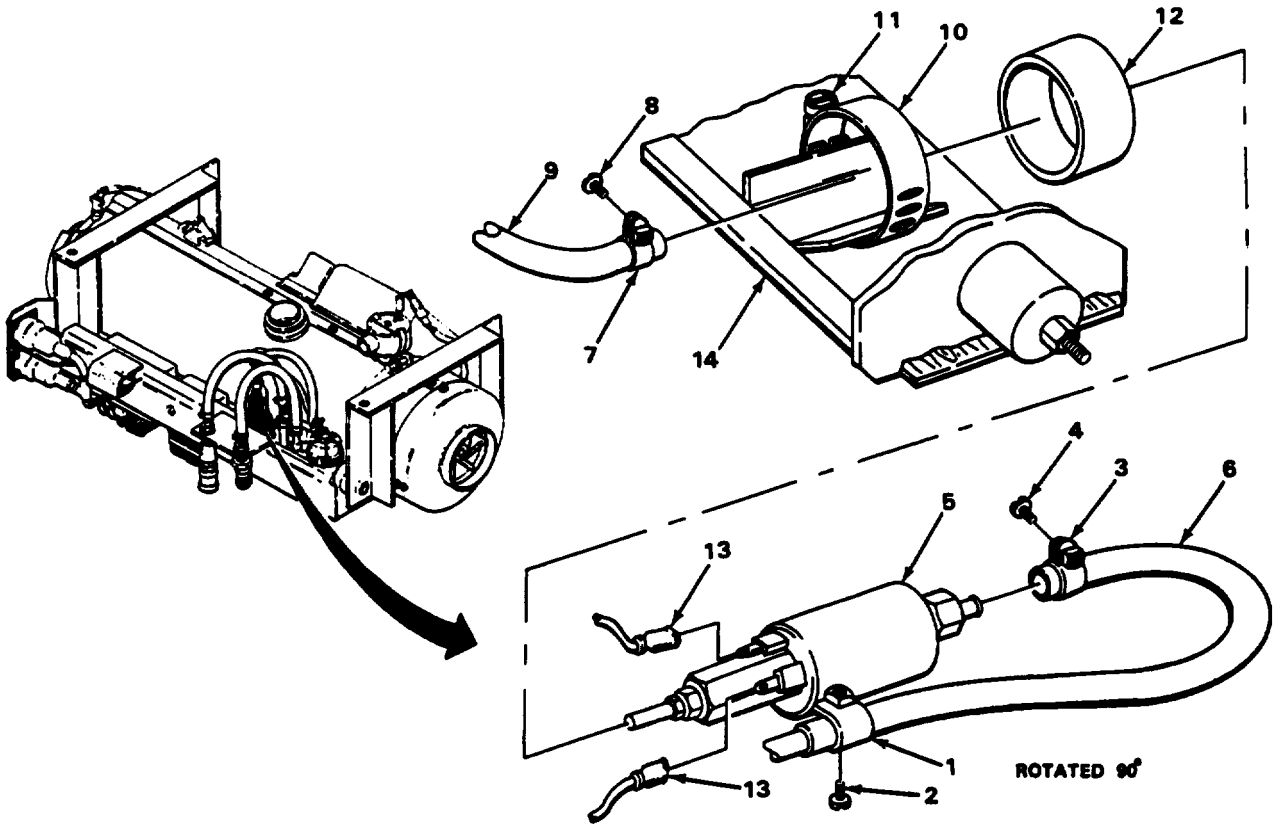

FUEL PUMP - ESPAR V7S - Continued

LOCATION	ITEM	ACTION	REMARKS
INSTALLATION - Continued			
13. Fuel pump (1)	Two connectors (2)	Install.	
14. Clamp (3)	Fuel pump (1) and cushion (4)	Install.	
15.	Screw (5)	a. Place clamp (10) ring in position. b. Tighten.	
16. Fuel pump (1)	Outlet hose (6) with clamp (7)	Install.	
17. Clamp (7)	Screw (8)	Tighten.	
18. Fuel pump (1)	Inlet hose (9) with clamp (10)	Install.	
19. Clamp (10)	Screw (11)	a. Tighten. b. Discard fuel in drain pan.	
20. Clamp (12)	Screw (13)	Tighten.	

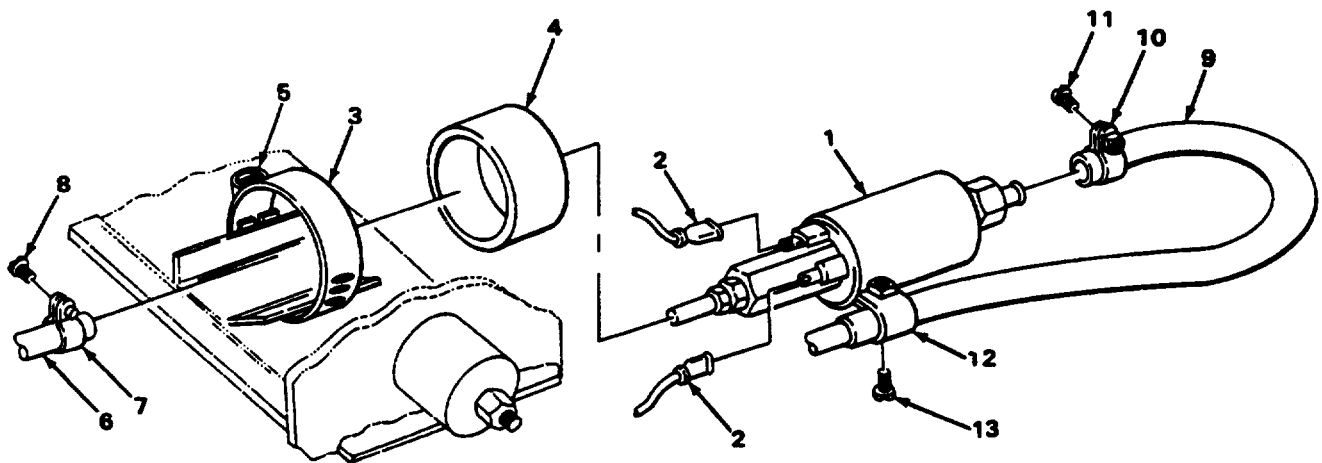

TASK ENDS HERE

HEAT REGULATOR - ESPAR V7S

This task covers:

- a. Removal
- b. Installation

INITIAL SETUP

Tools

Tool Kit, Mechanics Gen (Item 1, Appendix B)
 Key, socket-head screw, square drive, 2.5-mm
 (Item 3, Appendix B)

Personnel Required

63G

LOCATION	ITEM	ACTION	REMARKS
----------	------	--------	---------

REMOVAL

- | | | | |
|-----------------------------|----------------------|---|--|
| 1. Clamp (1) | Screw (2) | Unscrew part way. | |
| 2. Clamp (1) and heater (3) | Harness (4) | Pull out and move away from heater (4). | |
| 3. Heat regulator (5) | Three connectors (6) | Remove. | |

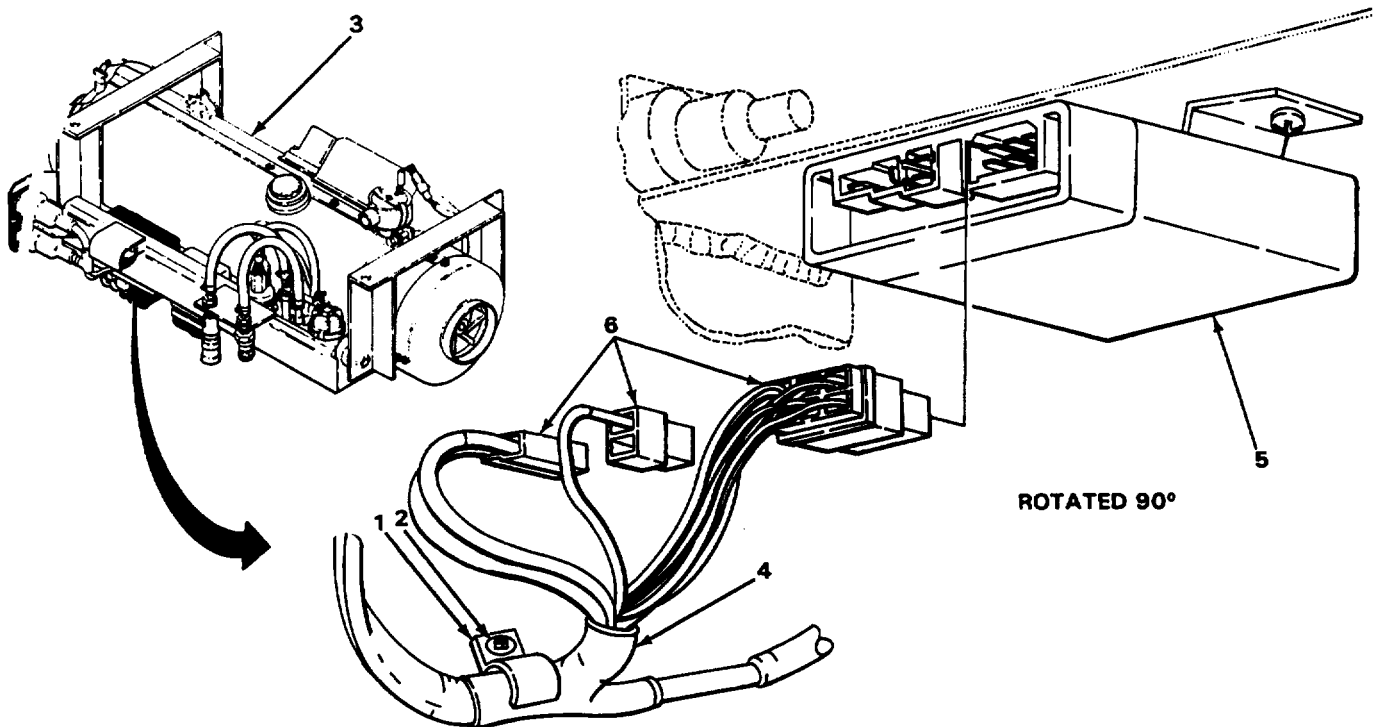

HEAT REGULATOR - ESPAR V7S - Continued

LOCATION	ITEM	ACTION	REMARKS
REMOVAL - Continued			
4. Heat regulator (l)	Two screws (2), nuts (3), and washers (4)	Unscrew and remove.	
5. Mounting bracket(5)	Heat regulator (1)	Remove.	
INSTALLATION			
6. Mounting bracket(5)	Heat regulator (1)	Install.	
7. Heat regulator (l)	Two screws (2), nuts (3), and washers (4)	Screw in and tighten.	
8.	Three connectors (6)	Push in.	
9. Clamp (7)and heater(8)	Harness (9)	Install,	
10. Clamp (7)	Screw (1 0)	Tighten.	

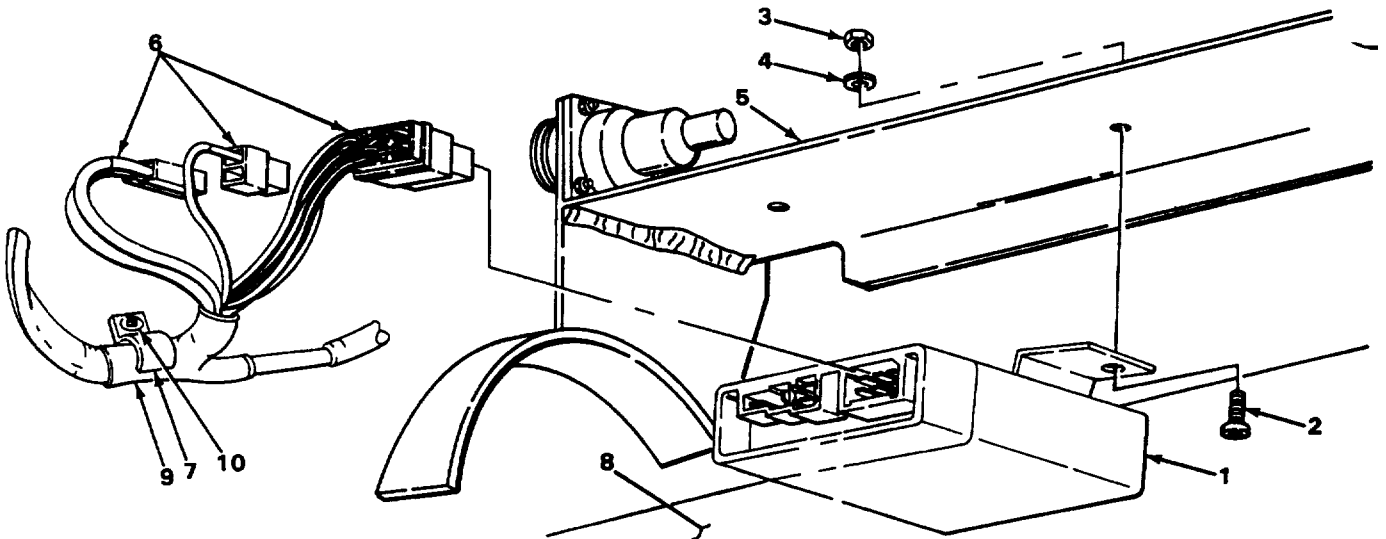

TASK ENDS HERE

IMPULSE SWITCH - ESPAR V7S

This task covers:

- a. Removal
- b. Installation

INITIAL SETUP

Tools	Personnel Required
Tool Kit, Mechanics Gen (Item 1, Appendix B)	63G

LOCATION	ITEM	ACTION	REMARKS
----------	------	--------	---------

REMOVAL

- | | | |
|-----------------------|---|---------|
| 1. Impulse switch (1) | Connector (2) | Remove. |
| 2. | Two screws (3), nuts (4), and washers (5) | Remove. |

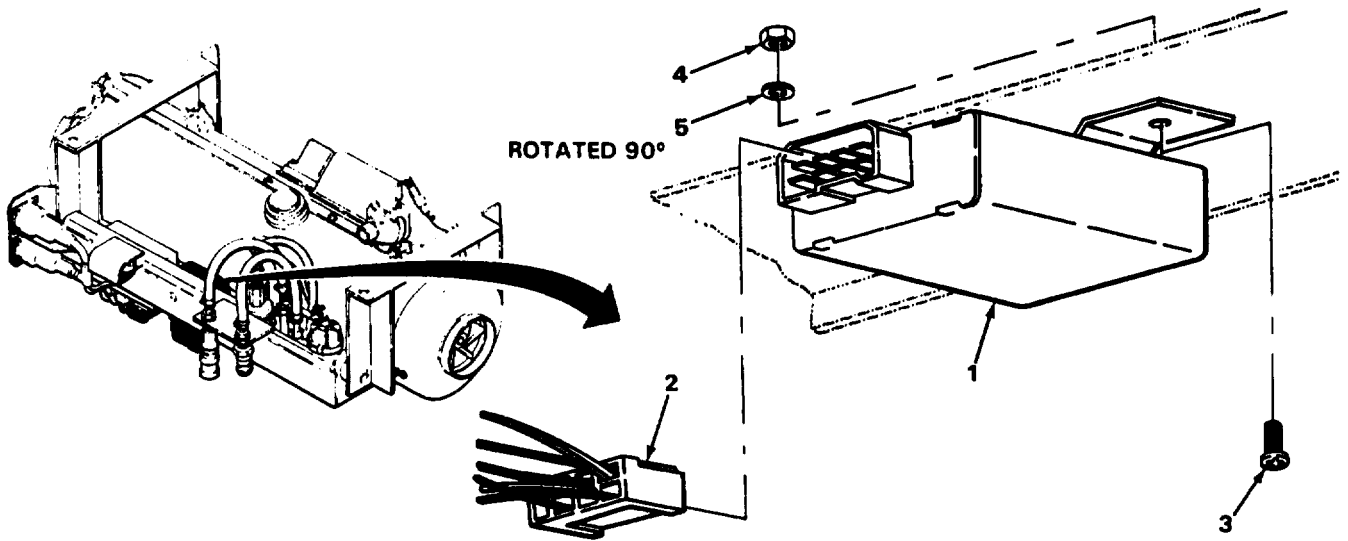

IMPULSE SWITCH - ESPAR V7S

LOCATION	ITEM	ACTION REMARKS
----------	------	-------------------

REMOVAL - Continued

3. Mounting bracket (1)	Impulse switch (2)	Remove,
-------------------------	--------------------	---------

INSTALLATION

4. Mounting bracket (1)	impulse switch (2)	Install.
5. impulse switch (5)	Two washers (3), screws (4), and nuts (5)	Screw in and tighten.
6.	Connector (6)	Install.

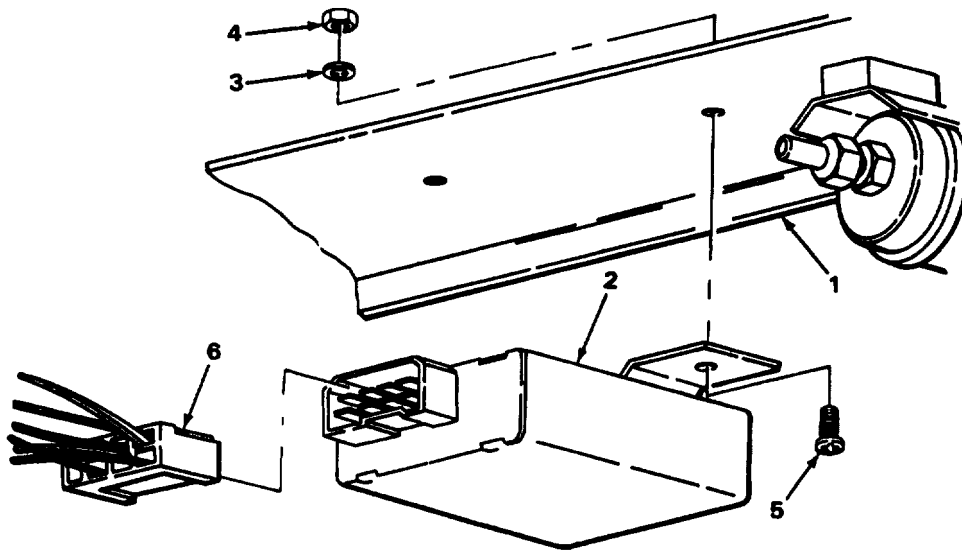

TASK ENDS HERE

RADIO FILTER - ESPAR V7S

This task covers:

- a. Removal
- b. Installation

INITIAL SETUP

Tools	Personnel Required
Tool Kit, Mechanics Gen (Item 1, Appendix B)	63G
Materials/Parts	Equipment Condition
Sealant, silicon (Item 6, Appendix C) Tags, marking (Item 9, Appendix C)	Hood removed (page 3-135) Blower motor removed (page 3-185)

LOCATION	ITEM	ACTION	REMARKS
----------	------	--------	---------

REMOVAL

NOTE

Tag all wires, connectors, and terminals to aid during installation (page 2-3).

1. Heater (1)	Grommet (2)	Pry out.
2. Terminal strip (3)	Two leads (4)	a. Cut off sealant. b. Remove,
3. Heater (1)	Radio filter (5)	Remove.

INSTALLATION

4. Heater (1)	Radio filter (5)	Install.
5. Terminal strip (3)	Two leads (4)	a. Install. b. Apply sealant to terminals and leads.

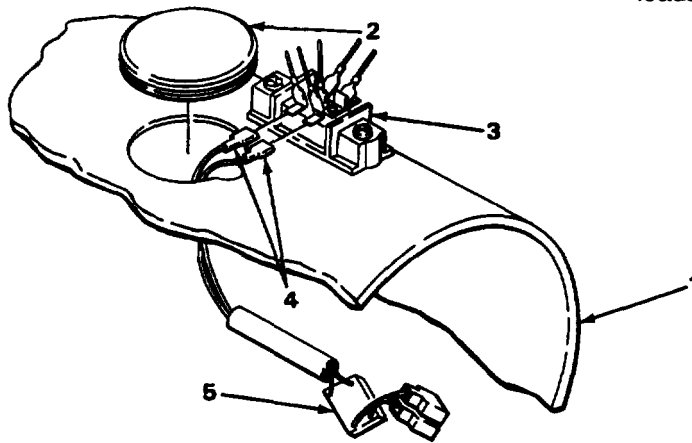

RADIO FILTER - ESPAR V7S - Continued

LOCATION	ITEM	ACTION REMARKS
INSTALLATION - Continued		
6. Heater (1)	Two leads (2)	a. Push into notch on side of hole b. Apply sealant to terminals and leads.
7.	Grommet (3)	Install.

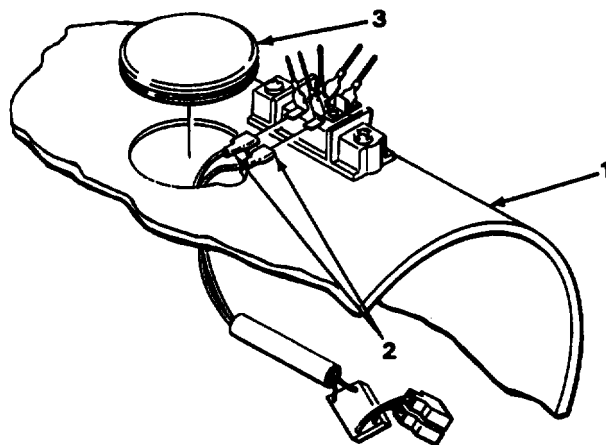

NOTE
FOLLOW-ON MAINTENANCE:

1. Install blower motor (page 3-185).
2. Install hood (page 3-135).

TASK ENDS HERE

BLOWER MOTOR AND IMPELLER - ESPAR V7S

This task covers:

- a. Removal
- b. Installation

INITIAL SETUP

Tools	Personnel Required
Tool Kit, Mechanics Gen (Item 1, Appendix B) Extension, 3/8-inch drive, 3-inch (Item 6, Appendix B) Handle, ratchet, 3/8-inch drive (Item 6, Appendix B)	63G

LOCATION	ITEM	ACTION	REMARKS
----------	------	--------	---------

REMOVAL

- | | | |
|-------------------------------|--------------------|--|
| 1. Casing (1) and cap (2) | Six screws (3) | a. Prior to removal, mark casing (1) and cap (2)
b. Unscrew and remove. |
| 2. Casing (1) | Cap (2) | Remove. |
| 3. Mounting bracket clamp (4) | Screw (5) | Unscrew part way. |
| 4. Motor (6) and impeller (7) | Retaining clip (8) | Pry off. |
| 5. Motor (6) | Impeller (7) | Remove. |
| 6. Support ring (9) | Three screws (10) | a. Prior to removal, mark casing (1) and ring (9).
b. Unscrew and remove. |
| 7. Burner assembly (11) | Support ring (9) | Remove. |

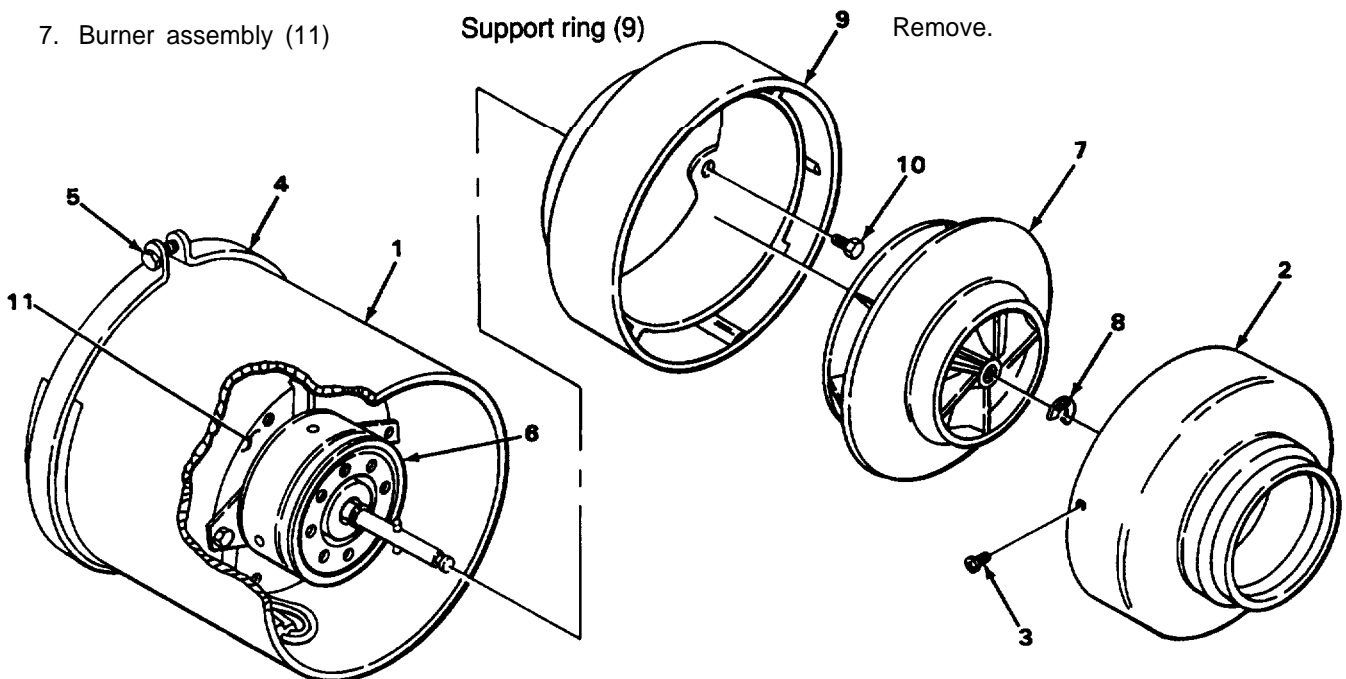

BLOWER MOTOR AND IMPELLER - ESPAR V7S - Continued

LOCATION	ITEM	ACTION REMARKS
REMOVAL - Continued		
8. Motor (1)	Two screws (2)	Unscrew and remove.
9. Casing (3)	Motor (1)	Remove.
10. Connector (4)	Connector (5)	Pull apart.
INSTALLATION		
11. Connector (5)	Connector (4)	a. Push together. b. Push down along side of burner assembly (6).
12. Burner assembly (6)	Motor (1)	a. Install. b. Turn shaft until it is engaged in coupler (7). Motor will seat against heat exchanger when coupler is engaged.
13. Motor (1)	Two screws (2)	Screw in and tighten.
14. Burner assembly (6)	Support ring (8)	Install. Notch must be placed over motor lead slot.
15. Support ring (8)	Three screws (9)	Screw in and tighten.
16. Motor (1)	Impeller (10)	a. Install. b. Turn until pegs on shaft and keying slots engage.
17. impeller (10)	Retaining clip (11)	Install.
18. Mounting bracket clamp (12)	Screw (13)	Screw in and tighten.
19. Casing (3)	Cap (14)	Install.
20. Casing (3) and cap (14)	Six screws (15)	Screw in and tighten.

LOWER MOTOR AND IMPELLER - ESPAR V7S - Continued

LOCATION	ITEM	ACTION	REMARKS
----------	------	--------	---------

INSTALLATION - Continued

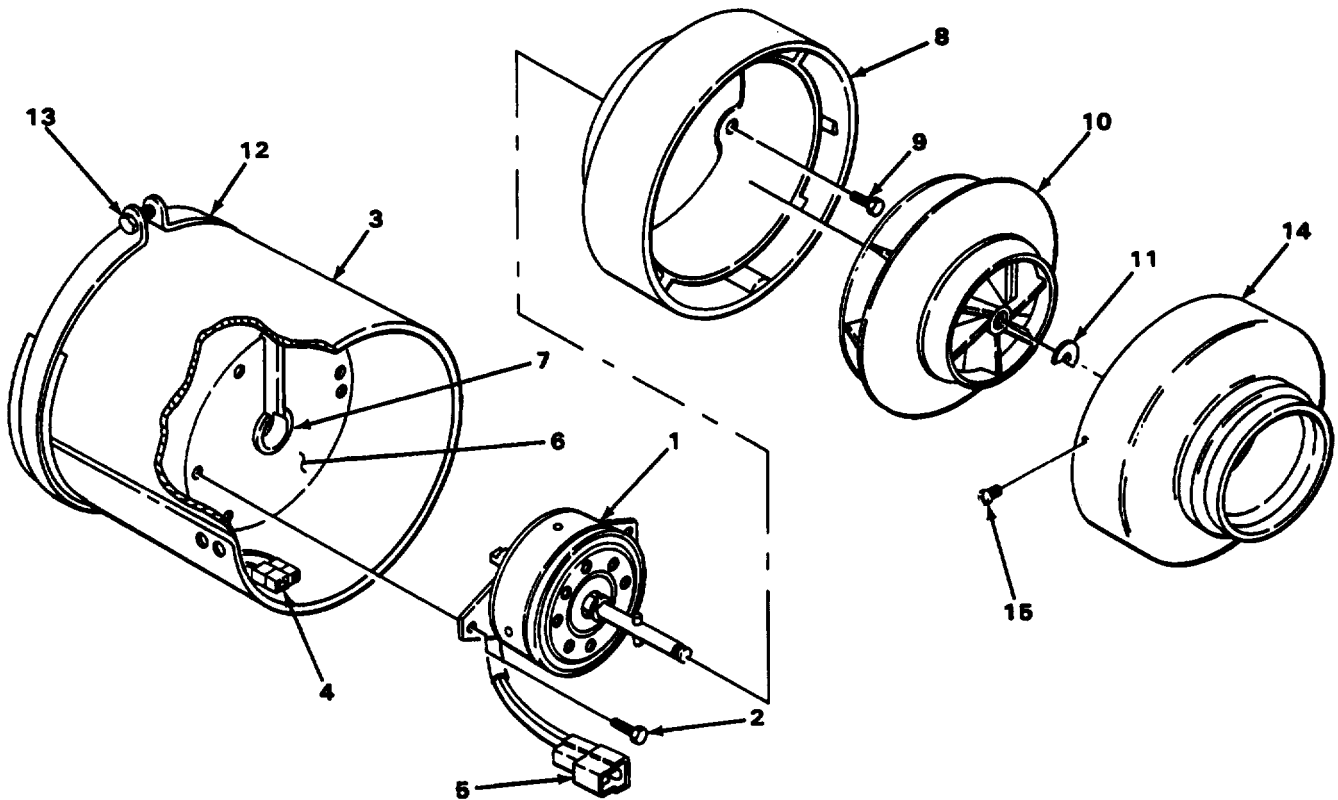

TASK ENDS HERE

BURNER ASSEMBLY AND HEAT EXCHANGER = ESPAR V7S

This task covers:

- a. Removal
- b. Installation

INITIAL SETUP

Tools	Equipment Condition
Tool Kit, Mechanics Gen (Item 1, Appendix B)	Wiring harness removed (page 2-1 54)
Materials/Parts	Solenoid valve removed (page 3-152)
Gasket, burner assembly	Temperature sensor removed (page 3-140)
Mask, protective	Overheat switch removed (page 3-148)
Personnel required	Thermostatic switch removed (page 3-142)
63G	Igniter spark generator removed (page 3-136)
	Fixed capacitor removed (page 3-146)
	Terminal board removed (page 3-150)
	Fixed wire resistor removed (page 3-146)
	Glow plug removed (page 3-138)
	Mounting assembly removed (page 3-163)
	Radio filter removed (page 3-1 83)

LOCATION	ITEM	ACTION
		REMARKS

REMOVAL

WARNING

Heat exchanger linings contain asbestos fibers. Protective mask must be worn while performing this task. Failure to do so could result in injury or death to personnel.

1. Casing (1) and hood (2)	Three screws (3)	Unscrew and remove,
2. Casing (1)	Hood (2)	Remove.
3.	Two screws (4)	Unscrew and remove.
4. Clamp (5)	Screw (6)	Unscrew part way.
5. Fuel tube (7)	Fuel hose (8) with clamp (5)	Twist and remove,
6. Casing (1)	Grommet (9)	Pry off.
7. Heat exchanger (1 O)	Casing (1)	a. Spread apart. b. Remove.
8.	Grommet (11)	Pry off.
9. Burner assembly (12)	Six nuts (13)	Unscrew and remove.

BURNER ASSEMBLY AND HEAT EXCHANGER - ESPAR V7S .Continued

LOCATION	ITEM	ACTION REMARKS
----------	------	-------------------

REMOVAL - Continued

10. Heat exchanger (10)	Burner assembly (12) with gasket (14)	a. Remove. b. Scrape out gasket (14). c. Discard gasket (14). d. Look for cracks in welds on exchanger (10). If welds are cracked or damaged, replace exchanger.
-------------------------	---------------------------------------	---

11. Burner assembly (12)	Coupling (15)	Remove,
--------------------------	---------------	---------

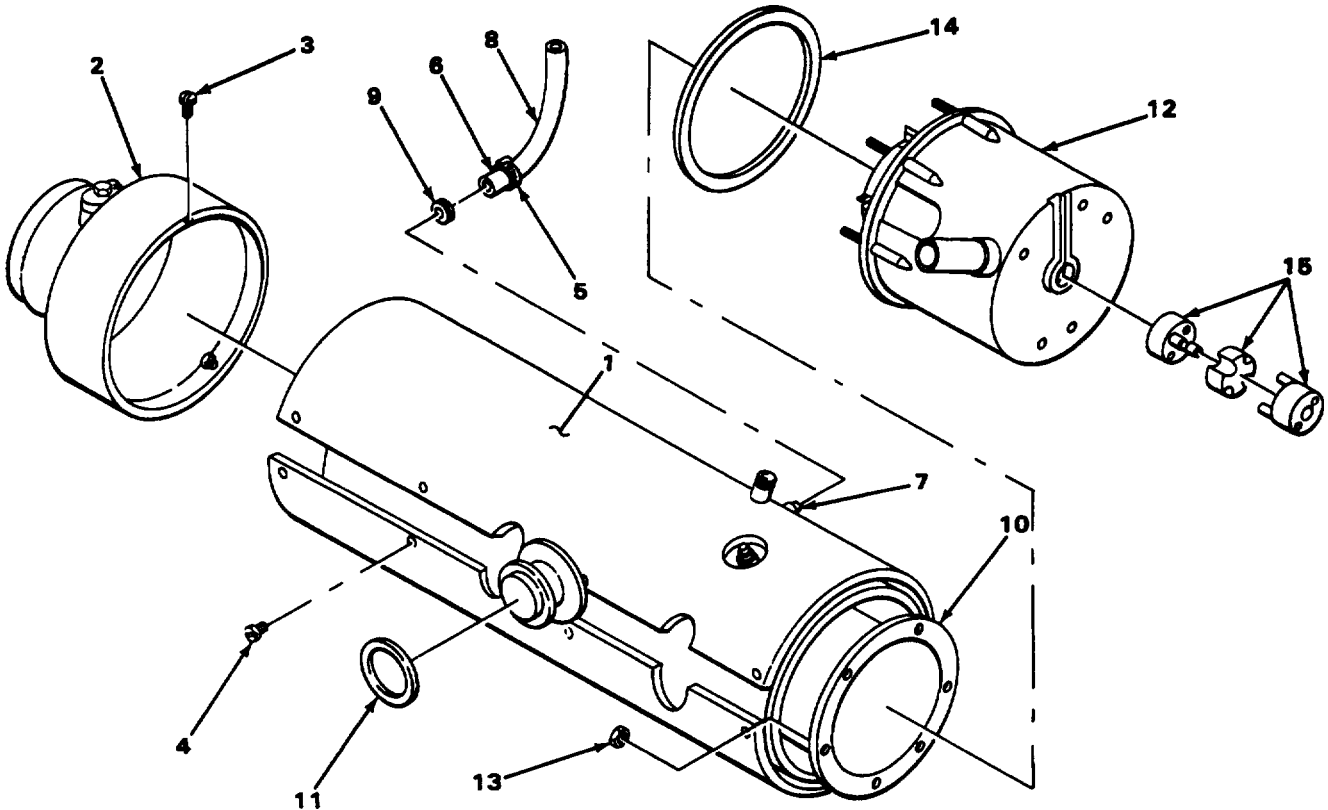

BURNER ASSEMBLY AND HEAT EXCHANGER - ESPAR V7S - Continued

LOCATION	ITEM	ACTION REMARKS
INSTALLATION		
12. Burner assembly (1)	Coupling (2)	Install.
13.	New gasket (3)	Install.
14. Heat exchanger (4)	Burner assembly (1) with gasket (3)	Install.
15. Burner assembly (1)	Six nuts (5)	Screw in and tighten.
16. Heat exchanger (4)	Grommet (6)	Pry into position.
17.	Casing (7)	a. Spread apart. b. Install.
18. Casing (7)	Grommet (8)	Install.
19. Fuel tube (9)	Fuel hose (10) with clamp (11)	Twist into position.
20. Clamp (11)	Screw (12)	Screw in and tighten.
21. Casing (7)	Two screws (13)	Screw in and tighten.
22.	Hood (14)	Install.
23. Casing (7) and hood (14)	Three screws (15)	Screw in and tighten.

BURNER ASSEMBLY AND HEAT EXCHANGER - ESPAR V7S - Continued

LOCATION	ITEM	ACTION	REMARKS
----------	------	--------	---------

INSTALLATION - Continued

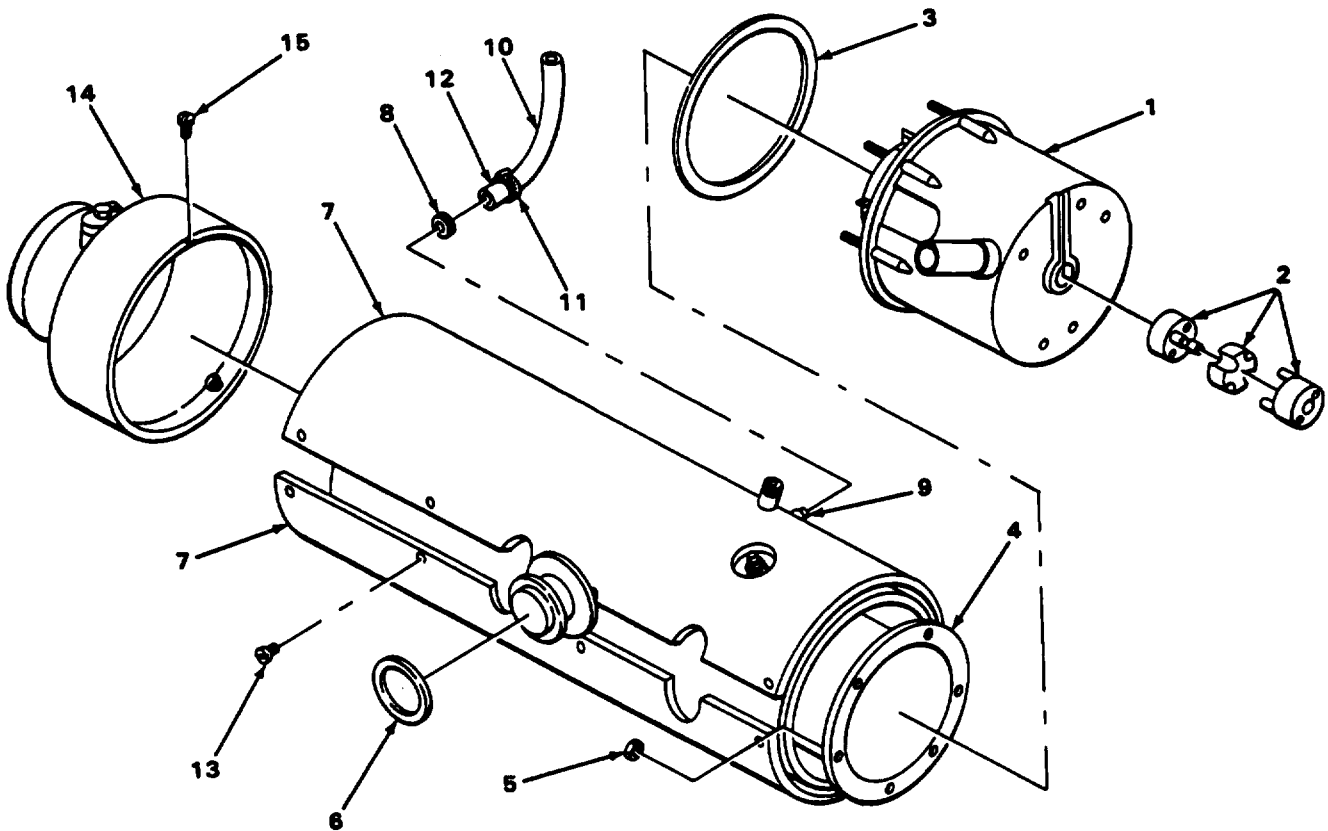

NOTE

FOLLOW-ON MAINTENANCE:

1. Install radio filter (page 3-183).
2. Install mounting assembly (page 3-163).
3. Install glow plug (page 3-138).
4. Install fixed wire resistor (page 3-146).
5. Install terminal board (page 3-150).
6. Install fixed capacitor (page 3-146).
7. Install ignitor spark generator (page 3-136).
8. Install thermostatic switch (page 3-142).
9. Install overheating switch (page 3-148).
10. Install temperature sensor (page 3-140).
11. Install solenoid valve (page 3-152).
12. Install wiring harness (page 3-154).

TASK ENDS HERE

Section IV. DIRECT SUPPORT AND GENERAL SUPPORT TEST PROCEDURES

Explanation of Columns	3-193	Test Procedures-Espar Heaters .	3-199
Introduction	3-192	Test Procedures-Stewart Warner	
Required Equipment for Testing		and Hupp Heaters	3-193
Heaters	3-192		

INTRODUCTION

Personnel heaters should be fully tested to make sure they work properly after servicing. Perform all steps in the test procedure, even if repairs were made to only one part. This way you will be sure the whole heater is working properly.

NOTE

Overheat switches should only be tested after being replaced or they are believed to be defective.

REQUIRED EQUIPMENT FOR TESTING HEATERS

The following items will be required to test heaters:

1. Heater test stand model VHTS heat and -89102. See TM 9-4910-7551-13&P.

NOTE

When testing the Stewart-Warner 10560M24B1 model heater, the 24-volt dc power source must be filtered to 5 percent ripple maximum.

2. A power source (either a power supply or batteries) capable of supplying 24 Vdc. at a current of at least 20 amps.
3. An ammeter (0-25 amps minimum) for measuring supply current. This can be part of the power supply or a separate meter.
4. A supply of fuel delivered to the heater at a pressure of 3 to 15 psi (20.7 to 103.4 kPa).
5. A flexible hose for piping exhaust gases outside when testing heaters inside.

WARNING

Never operate heater inside without venting the exhaust out of the test area. Heaters generate carbon monoxide gas. Injury or death to personnel could result.

6. A timer or wristwatch with second hand for timing heater functions.

NOTE

Item 7 is mandatory for testing the overheat switch. Do not attempt the overheat test without the proper ductwork.

REQUIRED EQUIPMENT FOR TESTING HEATERS - Continued

- 7. An insulated outlet duct 44 inches long with thermometer or pyrometer.

EXPLANATION OF COLUMNS

The test procedures you will be using appear in the form of tables which are arranged in the following columns:

ACTION-What to do. Perform all actions in the order listed.

RESULTS-What should happen after an action is performed. For most actions, there are different results for each heater. If no result is listed, go on to the next action.

REMARKS-Explanations for actions or results. Remarks will appear in **bold face type**.

THINGS TO CHECK-What to check if you do not get the results indicated.

TEST PROCEDURES - STEWART-WARNER AND HUPP HEATERS

ACTION	RESULTS	REMARKS	THINGS TO CHECK
--------	---------	---------	-----------------

1. Install heater on test stand.
2. Remove guard (page 2-31).
3. Connect fuel supply to fuel inlet.
4. Connect test stand wiring harness to input connector.

WARNING

Never operate heater inside without venting the exhaust out of the test area. Heaters produce carbon monoxide gas. Injury or death to personnel could result.

5. Connect exhaust hose to heater exhaust port.
6. If using a power supply, adjust for output of 21 to 26 Vdc.

TEST PROCEDURES - STEWART-WARNER AND HUPP HEATERS- Continued

ACTION	RESULTS	REMARKS THINGS TO CHECK
--------	---------	----------------------------

7. Set control box for low heater operation. Start heater (Chapter2, Section Vi).

Start timer as soon as heater is turned on.

NOTE

If supply voltage drops to below 21 Vdc. during start, all test results maybe wrong. Readjust for 21 to 26 Vdc. with heater on. Turn heater off, and wait at least 5 minutes before restarting.

8. Note supply current during start cycle.

- Model 10560C24-12 to 18 amps
- Model 10560M-14 to 21 amps
- Model MF510B, MF510C-15 to 20 amps
- Model MF60A-24VI, MF60B-24V-16 to 21 amps
- All models-Electrical connections

9. Measure ignitor voltage.

- Model 10560C24, 10560M-1 0,0 to 11.0 Vdc.
 - Igniter control, voltage limiter
- Model MF510B-19 to 26 Vdc.
 - Igniter, Igniter relay
- Model 510C-17 to 18 Vdc.
 - Igniter, Power control
- MF60A-24V
 - MF60B-24V-19 to 30 Vdc.
 - Igniter, Power control

TEST PROCEDURES - STEWART-WARNER AND HUPP HEATERS-Continued

ACTION	RESULTS	REMARKS
		THINGS TO CHECK

10. Note how long it takes for heater to start.

Model 10560C24, 10560M-75 seconds maximum

All Hupp Models-2 to 4 minutes

For timing purposes, when the outlet air temperature starts going up, the heater has started.

All models-Fuel supply, Ignition system, Flame detector switch

11. Note how long it takes for the flame detector switch to shift the blower motor to full speed.

Model 10560C24, 10560M-105 seconds maximum

Models MF510B, MF510C,- 30 to 60 seconds after blower starts at slow speed
MF60A24V, MF60B-24V

All models-Flame detector switch adjustment

12. Note supply current during run cycle.

Model 10560C24-9 to 16 amps

Model 10560M-13 to 19 amps

MF60A-24V, MF60B-24V-15 to 20 amps

Models MF510B, MF510C-10 to 18 amps

All models-Electrical connectors

TEST PROCEDURES - STEWART-WARNER AND HUPP HEATERS- Continued

ACTION	RESULTS	REMARKS THINGS TO CHECK
--------	---------	----------------------------

13 Check Hi/LO operation as follows:

- a. Note temperature reading in outlet duct.
- b. Set control box for HI heater operation.
- c. Note new reading after a few minutes.
Ail models-Reading should nearly double.

Stewart-Warner heaters-Fuel control valve adjustment,
restriction solenoid

Hupp heaters -Fuel regulator valve adjustment, Hi/LO pressure regulator, Hi/LO fire relay

NOTE

Step 14 is a test of the overheat switch. Perform this test only if the overheat switch was replaced or is believed to be defective.

Do not perform step 14 if running the heater on gasoline.

Always have a fire extinguisher handy when performing step 14.

Never perform this test alone; have someone with you.

14. Check operation of overheat switch as follows:

- a. Set control box for HI heater operation.
- b. Connect test continuity to overheat switch.

On Stewart-Warner heaters, connect to overheat switch terminal 30.

On Hupp heaters, connect to terminal 7 of terminal strip.

- c. Block off about 70 percent of the ventilation air inlet exhaust doughnut insert (item 1, appendix E).

TEST PROCEDURES-STEWART - WARNER AND HUPP HEATERS= Continued

ACTION	RESULTS	REMARKS THINGS TO CHECK
--------	---------	----------------------------

14. Check operation of overheat switch as follows-Continued

d. Place pyrometer/thermometer in the center of the duct approximately 42 inches (1067-mm) from the heat exchanger outlet,

e. If overheat switch does not engage or test light does not go out when outlet air temperature reaches 325° to 475°(167.2°C to 241.1 °C), proceed to step 16.

15. Check operation of valve thermostat for Stewart-Warner models.

Check thermostat for cracks, loose or damaged terminals, and distortion. Thermostat must be closed when temperature is reduced between 43° and 57°F. Thermostat must open when temperature rises between 65° and 75°. If thermostat is questionable, it can be checked using a multimeter set to the ohms function, while chilling thermostat with ice. Do not immerse in fluids. Body temperature can be used to provide enough heat to warm it to above 75° to check opening point.

16. Power control test procedures.

a. Connect two 100 watt resistors in parallel to substitute the igniter load for the voltage regulator. Attach the parallel resistors or an igniter to Module lead "E" (1).

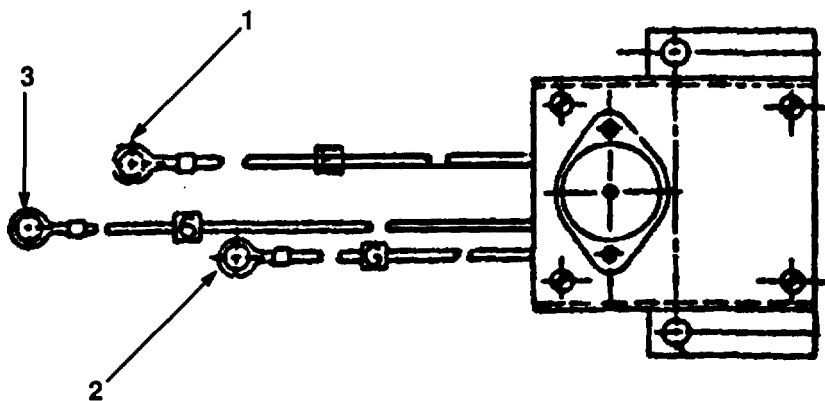

b. Connect module lead "G" (2) and power supply's ground or negative terminal together.

TEST PROCEDURES-STEWART - WARNER AND HUPP HEATERS- Continued

ACTION	RESULTS	REMARKS
		THINGS TO CHECK

c. Apply 24.0 + 0.5vdc to module lead "6" (3).

d. Allow ten seconds for voltage at resistor or ignitor stabilize. A good module will show between 15 and 17 vdc.

CAUTION

Ignitor gets hot, do not touch.

e. A defective pass together will be open (resistor voltage less than 1vdc) or shorted (resistor voltage equal to power supply voltage). This transistor should be replaced.

f. Other voltages at the resistor indicate that the module is out of adjustment since there is no provision for adjustment; replace module.

17. Shut down heater, and time purge cycle.

Stewart-Warner heaters-1 to 3 1/2 minutes

Models MF510B, MF510C-2 to 3 1/2 minutes

NOTE

Misadjusted flame detector switches can be quickly readjusted as follows:

1. Wait until heat exchanger is fully cooled.
2. Turn flame detector switch adjustment screw counterclockwise until blower motor stops.

18. Disconnect exhaust hose from heater exhaust port.

19. Disconnect test stand wiring harness from input connector.

20. Disconnect fuel supply from fuel inlet.

21. Install guard pages 2-32 (Hupp models); 2-42 (Stewart-Warner models).

22. Remove heater from test stand.

TEST ENDS HERE

TEST PROCEDURES - ESPAR HEATER

ACTION	RESULTS	REMARKS
		THINGS TO CHECK

1. Install heater on test stand.
2. Remove hood (page 3-135).
3. Connect fuel supply to fuel inlet.
4. Connect test stand wiring harness to input connector.

WARNING

Never operate heater inside without venting the exhaust out of the test area. Heaters produce carbon monoxide gas. injury or death to personnel could result.

5. Connect exhaust hose to heater exhaust post.
6. Adjust power supply for 19.5 VDC output.
7. Start heater (page 2-61).
 - Heater should not run (page 3-1 8).
8. Adjust power supply for output of 20.5 VDC.
9. Start heater momentarily, then shutdown.
 - Heater blower should run while switch is on.
10. Adjust power supply for output of 28.5 VDC.
11. Start heater momentarily, then shut down.
 - Heater blower should run while switch is on.
12. Adjust power supply for output of 24.5 VDC.
13. Start heater. Check current draw and start time.

- Maximum 19.0 amps during start-up
- Maximum 180 seconds until ignition
- Maximum 7.0 amps during run

NOTE

If heater does not ignite in 180 seconds, starter switch will automatically shut off.

TEST PROCEDURES - ESPAR HEATER- Continued

ACTION

RESULTS

REMARKS

THINGS TO CHECK

14. Check heater for fuel leaks. Repair any leaks before proceeding with test.

15. Check heater for high and low operational modes.

16. Check fuel flow.

Low Flow-0.67 cc/min max

High Flow-2.17 cc/min max

WARNING

Always have a fire extinguisher handy. Never perform the overheat test alone; have someone with you.

17. Check the overheat switch by simulating an overheat condition.

a. Attach 48-inch length of insulated duct to heat exchanger outlet (pages 3-179 and 3-180).

b. Insert thermometer through duct, 42 inches from heater outlet.

c. Start heater (page 2-61) and allow to operate for five minutes.

d. Remove connector (2) from temperature sensor (1) (page 3-140).

e. Bridge terminals of connector with electrical wire to allow current to bypass sensor.

f. Cover duct outlet with cardboard exhaust doughnut (Appendix E).

Heater shut off 300°-356F.

18. Check overheat reset button. Restart heater. Allow heater to run for five minutes.

19. Shut down heater and check purge cycle.

120 seconds to 360 seconds.

20. Disconnect exhaust hose from heater exhaust port.

21. Disconnect test stand wiring harness from input connector.

APPENDIX A

REFERENCES

A-1. PUBLICATION INDEX.

Index should be consulted frequently for latest changes, revisions, or references given in this appendix, and for new publications relating to material covered in this publication.

Consolidated Index of Army Publications and Blank Forms DA PAM 310-1

A-2. FORMS.

Refer to DA PAM 738-750, The Army Maintenance Management System (TAMMS), for instructions on the use of maintenance forms pertaining to the material.

A-3. OTHER PUBLICATIONS.

The following publications contain information pertinent to the major item material and associated equipment.

Procedures for Destruction of Tank-Automotive Equipment to
Prevent Enemy Use (U.S. Army Tank-Automotive Command) TM 750-244-6
First Aid for Soldiers FM 21-11
Heater Test Stand. TM 9-4910-755-13&P

APPENDIX B MAINTENANCE ALLOCATION CHART

Section I. INTRODUCTION

B-1. GENERAL.

a. This section provides a general explanation of all maintenance and repair functions authorized at various maintenance categories.

b. The Maintenance Allocation Chart (MAC) in section II designates overall authority and responsibility for the performance of maintenance functions on the identified end item or component. The application of the maintenance functions to the end item or component will be consistent with the capacities and capabilities of the designated maintenance categories.

c. Section III lists the tools and test equipment (both special tools and common tool sets) required for each maintenance function as referenced from section II.

d. Section IV contains supplemental instructions and explanatory notes for a particular maintenance function.

B-2. MAINTENANCE FUNCTIONS.

Maintenance functions will be limited to and defined as follows:

a. Inspect. To determine the serviceability of an item by comparing its physical, mechanical, and/or electrical characteristics with established standards through examination (e.g., by sight, sound, or touch).

b. test. To verify service ability by measuring the mechanical, pneumatic, hydraulic, or electrical characteristics of an item and comparing those characteristics with prescribed standards.

Service. Operations required periodically to keep an item in proper operating condition, i.e., to clean (includes decontaminate, when required), preserve, drain, paint, or replenish fuel, lubricants, or gases.

d. Adjust. To maintain or regulate, within prescribed limits, by bringing into proper or exact position or by setting the operating characteristics to specified parameters.

e. Aline. To adjust specified variable elements of an item to bring about optimum or desired performance.

f. Calibrate. To determine and cause corrections to be made or to be adjusted on instruments or test, measuring, and diagnostic equipment used in precision measurement. Consists of comparisons of two instruments, one of which is a certified standard of known accuracy, to detect and adjust any discrepancy in the accuracy of the instrument being compared.

g. Removal/Install To remove and install the same item when required to perform service or other maintenance functions. Install maybe the act of emplacing, seating, or fixing into position a spare, repair part, or module (component or assembly) in a manner to allow the proper functioning of a piece of equipment or system.

B-2. MAINTENANCE FUNCTIONS - Continued

h. Replace. To remove an unserviceable item and install a serviceable counterpart in its place. Replace is authorized by the MAC and shown as the 3rd position code of the SMR code.

i. Repair. The application of maintenance services¹, including fault location/troubleshooting², removal/installation, and disassembly/assembly procedures³ and maintenance actions⁴ to identify trouble and restore serviceability to an item by correcting specific damage, fault, malfunction, or failure in a part.

j. Overhaul That maintenance effort (service or action) prescribed to restore an item to completely serviceable/operational condition as required by maintenance standards in appropriate technical publications (i.e., DMWR). Overhaul is normally the highest degree of maintenance performed by the Army. Overhaul does not normally return an item to like-new condition.

k. Rebuild. Consists of those services/actions necessary for the restoration of unserviceable equipment to a like-new condition in accordance with original manufacturing standards. Rebuild is the highest degree of material maintenance applied to Army equipment. The rebuild operation includes the act of returning to zero those age measurements (hours/miles, etc.) considered in classifying Army equipment/components.

B-3. EXPLANATION OF COLUMNS IN THE MAC, SECTION II.

a. Column 1, Group Number. Column 1 lists functional group code numbers, the purpose of which is to identify maintenance significant components, assemblies, subassemblies, and modules with the next higher assembly. End item group number shall be '00'.

b. Column 2, Component/Assembly. Column 2 contains the names of components, assemblies, subassemblies, and modules for which maintenance is authorized and its useable on code. Uncoded items are applicable to all models. Identification of the useable on codes used in this publication are:

<u>Code</u>	<u>Used On</u>	<u>Code</u>	<u>Used On</u>
HE1	MF510B	HE5	MF60A-24V
HE2	10560M	HE6	V7S
HE3	10560C24	HE7	MF510C, MF60B-24V
		HE8	10560M24BI
		HE10	10560G

c. Column 3, Maintenance Function. Column 3 lists the functions to be performed on the item listed in Column 2. (See paragraph B-2 for a detailed explanation of these functions.)

¹ Services-Inspect, test, service, adjust, aline, calibrate, and/or replace.
² Fault locate/troubleshoot-the process of investigating and detecting the cause of equipment malfunctioning; the act of isolating a fault within a system or unit under test (UUT).
³ Disassemble/assemble-encompasses the step-by-step taking apart (or breakdown) of a spare/functional group coded item to the level of its least componency identified as maintenance significant (i.e., assigned as SMR code) for the category of maintenance under consideration.
⁴ Actions-welding, grinding, riveting, straightening, facing, remachinery, and/or resurfacing.

B-3. EXPLANATION OF COLUMNS IN THE MAC, SECTION II - Continued

d. Column 4, Maintenance Category, Column 4 specifies, by the listing of a work time figure in the appropriate subcolumn(s), the category of maintenance authorized to perform the function listed in column 3. This figure represents the active time required to perform that maintenance function at the indicated category of maintenance, if the number or complexity of the tasks within the listed maintenance function vary at different maintenance categories, appropriate worktime figures will be shown for each category. The worktime figure represents the average time required to restore an item (assembly, subassembly, components, module, end item, or system) to a serviceable condition under typical field operating conditions. This time includes preparation time (including any necessary disassembly/assembly time), troubleshooting/fault location, and quality assurance/quality control time in addition to the time required to perform the specific tasks identified for the maintenance functions authorized in the MAC. The symbol designations for the various maintenance categories are as follows:

- C - Operator or Crew
- O - Organizational
- F - Direct Support
- H - General Support
- D - Depot

e. Column 5, Tools and Equipment. Column 5 specifies, by code, those common tool sets (not individual tools) and special tools, TMDE, and support equipment required to perform the designated function.

f. Column 6, Remarks. This column shall, when applicable, contain a letter code, in alphabetical order, that shall be keyed to the remarks contained in Section IV.

B-4. EXPLANATION OF COLUMNS IN TOOL AND TEST EQUIPMENT REQUIREMENTS, SECTION III.

a. Column 1, Reference code. The tools and test equipment reference code correlates with a code used in the MAC, Section II, column 5.

b. Column 2, Maintenance Category. The lowest category of maintenance authorized to use the tool or test equipment.

c. Column 3, Nomenclature. Name or identification of the tool or test equipment.

d. Column 4, National Stock Number. The national stock number of the tool or test equipment.

e. Column 5, Tool Number. The manufacturer's part number.

B-5 EXPLANATION OF COLUMNS IN REMARKS, SECTION IV.

a. Column 1, Reference Code. The code recorded in column 6, Section II.

b. Column 2, Remarks. This lists information pertinent to the maintenance function being performed as indicated in the MAC, Section II.

Section II MAINTENANCE ALLOCATION CHART

(1) Group No.	(2) Component/Assembly	(3) Maint Function	(4) Maintenance Level					(5) Tool & Equip	(6) Remarks
			Unit		DS	GS	Depot		
			C	O	F	H	D		
22	Body, Chassis, and Hull Accessory Items								
2202	Guard HE1, HE2, HE3, HE5, HE7, HE8, HE10	Replace		0.1					1
	Flame Detector	Test		0.1					1
	Switch	Adjust		0.1					
	HE1, HE5, HE7	Replace		0.6					
	Ignitor	Inspect		0.1					1
	HE1, HE2, HE3, HE5, HE7	Test		0.1	0.1				
		Replace		0.3					
	Thermostat Assembly	Test		0.1					1
	HE1, HE5, HE7	Replace							
	Fuel Regulator valve (Pulsed Fuel Metering valve) HE1, HE2, HE3, HE5, HE7	Service		0.3	0.3				1,2
		Adjust			0.5				
		Replace			1.0				
		Repair			1.0				
	Thermostatic Switch (Flame Detector Switch) HE2, HE3, HE8, HE10	Test		0.1					1
		Adjust		0.1					
		Replace		0.4					
		Repair			0.4				
	Terminal Strip HE2, HE3, HE8, HE10	Inspect		0.1					1
		Replace		0.5					
	Ignition Control HE2, HE3, HE5, HE10	Test		0.1					1
		Replace		0.3					
	Overheat Switch HE2, HE3, HE8, HE10	Test		0.1	0.1				1
		Replace		0.3					
	Valve Thermostat HE2, HE3, HE8, HE10	Test		0.1					1
		Replace		0.3					
	Receptacle Connector HE1, HE5, HE7	Replace			1.0				1
	Relay, Hi/Lo Fire HE1, HE5, HE7	Test			0.1				1
		Replace			0.3				
	Relay, Valve HE1, HE5, HE7	Test			0.1				1
		Replace			0.3				
	Control Bracket Assembly HE1, HE5, HE7	Replace			1.0				1

Maintenance Levels: C: Operator/Crew F: Direct Support D: Depot
 O: Organizational H: General Support

Section II MAINTENANCE ALLOCATION CHART

(1) Group No.	(2) Component/Assembly	(3) Maint Function	(4) Maintenance Level					(5) Tool & Equip	(6) Remarks
			Unit		DS	GS	Depot		
			C	O	F	H	D		
22	Body, Chassis, and Hull Accessory Items-Continued								
2202	Capacitor HE5, HE7	Test Replace			0.1 0.5			1	
	Relay, Ignitor HE1	Test Replace			0.1 0.3			1	
	Power Control HE5, HE7	Test Replace			0.2 0.5			1,2	
	Heater Thermostat	Replace			0.1			1	
	Burner, Thermostat/Preheater Assembly HE1, HE5, HE7	Test Replace			0.1 0.8			1	
	Burner Plate HE1, HE5, HE7	Inspect Replace			0.2 1.5			1	
	Blower Assembly HE1, HE2, HE3, HE5, HE7, HE8, HE10	Replace Repair			0.7 1.0			1,2	
	Motor, Direct Current HE1, HE2, HE3, HE5, HE7, HE8, HE10	Test Replace			0.3 0.5			1,2	
	Valve Assembly, (Pulsed Fuel Metering Valve) HE8, HE10	Service Test Adjust Replace Repair		0.3	0.3 0.3 0.3 1.0 1.0			1,2	
	Voltage Regulator/Regulator Current HE2, HE3, HE7, HE8, HE10	Test Replace			0.1 0.3			1	
	Semiconductor Device HE3, HE10	Test Replace			0.1 0.3			1	
	Diode Mounting Assembly HE8, HE2	Test Replace			0.1 0.5			1,2	
	Burner Assembly HE2, HE3, HE8, HE10	Inspect Test Replace Repair			0.2 0.3 1.0 0.5			1,2	
	Maintenance Levels:			C: Operator/Crew O: Organizational	F: Direct Support H: General Support	D: Depot			

Section II. MAINTENANCE ALLOCATION CHART

(1) Group No.	(2) Component/Assembly	(3) Maint Function	(4) Maintenance Level					(5) Tool & Equip	(6) Remarks
			Unit		DS	GS	Depot		
			C	O	F	H	D		
22	Body, Chassis, and Hull Accessory Items-Continued								
2202	Hood HE6	Replace			0.1			1	
	Spark Generator, Ig- nitor HE6	Replace			0.3			1	
	Plug, Glow HE6	Replace			0.4			1	
	Sensor, Tempera- ture HE6	Replace			0.3			1	
	Switch, Thermosta- tic HE6	Replace			0.5			1	
	Capacitor, Fixed HE6	Replace			0.3			1	
	Resistor, Fixed HE6	Replace			0.6			1	
	Switch, Overheat HE6	Replace			0.4			1	
	Board, Terminal HE6	Replace			0.5			1	
	Valve, Solenoid HE6	Replace			0.5			1	
	Harness, Wiring HE6	Replace Repair			0.5 1.0			1,2	
	Mounting Assembly HE6	Replace			1.0			1	
	Pump, circulating HE6	Replace			0.6			1	
	Pump, Fuel HE6	Replace			0.6			1	
	Regulator, Heat HE6	Replace			0.6			1,2	
	Switch, Impulse HE6	Replace			0.6			1	
Maintenance Levels: C: Operator/Crew F: Direct Support D: Depot O: Organizational H: General Support									

Section II. MAINTENANCE ALLOCATION CHART

(1) Group No.	(2) Component/Assembly	(3) Maint Function	(4) Maintenance Level					(5) Tool & Equip	(6) Remarks
			Unit		DS	GS	Depot		
			C	O	F	H	D		
22	Body, Chassis, and Hull Accessory Items-Continued								
2202	Radio Filter HE6	Replace			1.0			1	
	Blower Motor and Impeller HE6	Replace			1.5			1	
	Motor, Direct Cur- rent HE6	Replace			0.5			1	
	Burner, Assembly and Heat Exchanger HE6	Replace			1.0			1	
Maintenance Levels: C: Operator/Crew F: Direct Support D: Depot O: Organizational H: General Support									

Section III. TOOLS AND TEST EQUIPMENT REQUIREMENTS

(1) REFERENCE CODE	(2) MAINTENANCE CATEGORY	(3) NOMENCLATURE	(4) NATIONAL STOCK NUMBER	
1	O,F	COMMON TOOLS Tool Kit, Mechanics Gen	5180-00177-7033	
2	O,F	Shop Equipment, Common Set No. 1	4910-00-754-0654	
3	O,F	Shop Equipment, Supplemental Set No. 1	4910-00-754-0653	
5	F	Thermometer, Self- indicating SPECIAL TOOLS: None	6685-00514-3755 P/N 0005(65092)	

Section IV. TOOL IDENTIFICATION LIST

(1) ITEM NUMBER	ITEMS NAME	(3) NATIONAL STOCK NUMBER	4 NUMBER	(5) REFERENCE
1	Drill, Twist: 1/16 In. Dia	5133-00-227-9646	40D1 878-5	Sc 491 O-95-CL-A74
2	Key, Socket Head Screw 3/32 In	5120-00-242-7410	BA27077-4	Sc 4910-95-CL-A74
3	Key, Socket Head Screw 25mm	5120-01-045-4887	68030	Cs 4910-95-CL-A74
4	Soldering Gun	3439-00-618-6623	D550982-1738	SC4910-95-CL-A74
5	Tool Kit Electrical Connector Repair	5180-00-876-9336	7550526	Sc 4910-95-CL-A74
6	Wench Set, Socket, 3/8 In Dr	5120-00-322-6231	51200017510	Sc 4910-95-CL-A74

APPENDIX C

EXPENDABLE SUPPLIES AND MATERIALS LIST

Section 1. INTRODUCTION

SCOPE

This appendix lists expendable supplies and materials you will need to operate and maintain the personnel heater. These items are authorized to you by CTA 50-970, Expendable Items (Except Medical, Class V, Repair Parts, and Heraldic Items).

EXPLANATION OF COLUMNS

a. Column (1) - Item Number. This number is assigned to the entry in the listing and is referenced in the narrative instructions to identify the material (e.g., Use cleaning compound, Item 5, App. D).

b. Column (2) - Level. This column identifies the lowest level of maintenance that requires the listed item.

- C - Operator/Crew
- O- Organizational Maintenance
- F - Direct Support

c. Column (3) - National Stock Number. This is the National Stock Number assigned to the item; use it to request or requisition the item.

d. Column (4) - Description. Indicates the Federal item name and, if required, a description to identify the item. The last line for each item indicates the Contractor And Government Entity (CAGE) code in parentheses followed by the part number.

e. Column (5) - Unit of Measure (U/M). Indicates the measure used in performing the actual maintenance function. This measure is expressed by a two-character alphabetical abbreviation (e.g., ea., in., pr.). If the unit of measure differs from the unit of issue, requisition the lowest unit of issue that will satisfy your requirements.

Section II. EXPENDABLE SUPPLIES AND MATERIALS LIST

(1) ITEM NUMBER	(2) LEVEL	(3) NATIONAL STOCK NUMBER	(4) DESCRIPTION (CAGE)	(5) U/M
1	O	6810-00-543-7415	Alcohol, Denatured	gal
2	O	7920-00-514-2417	Brush, Acid Swabbing (81348) HB-643 Box of 144	ea
3	O	3439-00-255-4571	Flux, Soldering, Paste	oz
4	O	5970-01-013-4571	Humiseal, (99109) P/N 1A33LU	

Section II. EXPENDABLE SUPPLIES AND MATERIALS LIST - Continued

(1) ITEM NUMBER	(2) LEVEL	(3) NATIONAL STOCK NUMBER	(4) DESCRIPTION(CAGE)	(5) U/M
5	0	7920-00-205-1711	Rags, Wiping (58536) A-A-531,50-pound (22.7-kg), bale	lb
6	0	8040-00-225-4548	Sealant, Silicon (RTV 102)	lb
7	0	3439-00-896-8746	Solder 80/40	lb
8	0	6850-00-664-5685 6850-00-281-1985 6850-00-285-8011	Solvent,Drycleaning,Typeoil (81348) PD-680 1quart (0.946-liter) can 1 -gallon (3.785-liter) can 55-gallon (208 liter) drum	qt gal gal
9	0	9905-00-537-8954	Tags, Marking, (81349) MiL-T-12755, Box of 50	ea
10	0	5970-00-543-1154	Tape, insulation, electrical: (81349) MiL-1 -15126	ro
11	0	5975-01-067-3359	Tie Wraps	
12	0	9505-00-293-4208	Wire, Non-electrical (96906) MS20995C32 (81348) QQW423	lb

APPENDIX D

UNIT, DIRECT SUPPORT AND GENERAL SUPPORT MAINTENANCE REPAIR PARTS AND SPECIAL TOOLS LISTS

SECTION 1. INTRODUCTION

I. Scope.

This RPSTL lists and authorizes spares and repair parts; special tools; special test, measurement, and diagnostic equipment (TMDE); and other special support equipment required for performance of Unit, Direct Support and General Support Maintenance of the Heaters, Vehicular. It authorizes the requisitioning, Issue, and disposition of spares, repair parts and special tools as indicated by the source, maintenance and recoverability (SMR) codes.

2. General.

In addition to Section 1. Introduction, this Repair Parts and Special Tools List is divided into the following sections:

a. *Section II. REPAIR Parts LIST.* A list of spares and repair parts authorized by this RPSTL for use in the performance of maintenance. The list also includes parts which must be removed for replacement of the authorized parts. Parts lists are composed of functional groups in ascending alphanumeric sequence, with the parts in each group listed in ascending figure and item number sequence. Bulk materials are listed in item name sequence. Repair kits are listed separately in their own functional group within Section II. Repair parts for repairable special tools are also listed in the section. Items listed are shown on the associated illustration(s) / figure(s).

b. *Section III. Special Tool List.* A list of special tools, special TMDE, and other special support equipment authorized by this RPSTL (as indicated by Basis of Issue (BOL) information in DESCRIPTION AND USABLE ON CODE column) for the performance of maintenance.

c. *Cross-reference Indexes.* A list, in National Item Identification Number (NIIN) sequence, of all National stock numbered items appearing in the listing, followed by a list in alphanumeric sequence of all part numbers appearing; in the listings. National stock numbers and part numbers are cross-referenced to each illustration, figure and item number appearance. The

figure and item number index lists figure and Item numbers in alphanumeric sequence and cross-references NSN, CAGE and part numbers.

3.Explanation of Columns (Sections II and III).

a. *ITEM NO. (Column (1)).* Indicates the number used to identify items called out in the illustration.

b. *SMR CODE (Column (2)).* The Source, Maintenance, and Recoverability (SMR) code is a 5-position code containing supply/requisitioning information, maintenance category authorization criteria and disposition instructions, as shown in the following breakout:

Source Code

1st two positions **XXxxx**

How you get an item

Maintenance Code

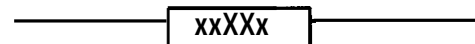

d3position

Who can install,
replace or use
the item

4th position

Who can
do complete
repair on the item

Recoverability Code

xxxxX

5th position

Who determines disposition action on
an unserviceable item

“Complete Repair. Maintenance capacity, capability, and authority to perform all corrective maintenance tasks of the “Repair” function in a use/user environment in order to restore service ability to a failed item.

(1) Source Code. The source code tells you how to get an item needed for maintenance, repair or overhaul of an end item/equipment. Explanations of source codes follows:

<u>Code</u>	<u>Application/Explanation</u>
PA	Stocked items; use the applicable NSN to request/ requisition items with these
PB	source codes. They are authorized to the
PC**	category indicated by the code entered in
PD	3d position of the SMR code.
PE	
PF	
PG	I *Items coded PC are subject to deterioration.
KD	Items with these codes are not to be
KF	requested/requisitioned individually. They
KB	are part of a kit which is authorized to the maintenance category indicated in the 3d position of the SMR code. The complete kit must be requisitioned and applied.
MO-(Made at UM AVUM Level)	Items with these codes are not to be requested/ requisitioned individually. They must be made from bulk material which is identified by the part number in the DESCRIPTION AND USABLE ON CODE (UOC) column and listed in the Bulk Material group of the repair parts list in this
MF-(Made at DS/ A VUM Level)	RPSTL. If the item is authorized to you by the 3d position code of the SMR code, but if the source code indicates it is made at a higher level, order the item from the higher level of maintenance.
ML-(Made at Specialized Repair Act (SRA))	
MD-(Made at Depot)	
AO-(Assembledby DS/AVUM Level)	Items with these codes are not to be requested/requisitioned individually The parts that make up the assembled item must be requisitioned or fabricated and assembled at the level of maintenance indicated by the source code. If the 3d position code of the SMR code by authorizes you to replace the item, but the source code indi-
AF-(Assembledby DS/AVIM Level)	
AH-(Assembledby GS Category)	
AL-(Assembled by SRA)	

AD-(Assembled by DEPOT) cates the item is assembled at a higher level, order the item from the higher level of maintenance.

- XA - Do not requisition an 'XA'-coded Item. Order its next higher assembly. (Also, refer to the NOTE below.)
- XB- If an "XB" item is not available from salvage order it using the CAGE and part number given
- XC- Installation drawing, diagram, instruction sheet, field service drawing, that is identified by the manufacturer's part number.
- XD- Item is not stocked. Order an "XD"-coded item through normal supply channels using the CAGE and part number given, if no NSN is available.

NOTE: Cannibalization or controlled exchange, when authorized, may be used as source of supply for items with the above source codes, except for those source coded "XA" or those aircraft support' items restricted by requirements of AR 700-42.

(2) Maintenance Code. Maintenance codes tell you the level(s) of maintenance authorized to USE and REPAIR support items. The maintenance codes are entered in the third and fourth positions of the SMR Code as follows:

(a) The maintenance code entered in the third position tells you the lowest maintenance level authorized to remove, replace and use an item. The maintenance code entered in the third position will indicate authorization to one of the following levels of maintenance:

<u>Code</u>	<u>Application/Explanation</u>
C -	Crew or operator maintenance done within unit or aviation unit maintenance.
O -	Unit maintenance or aviation unit category can remove, replace and use the item.
F -	Direct support or aviation intermediate level can remove, replace and use the item.
H -	General support level can remove, replace .. and use the item.
L -	Specialized repair activity can remove, replace and use the item.

D - Depot level can remove, replace and use the item.

(b) The maintenance code entered in the fourth position tells whether or not the item is to be repaired and identifies the lowest maintenance level with the capability to do complete repair (i.e., perform all authorized repair functions.) (NOTE: Some limited repair may be done on the item at a lower level of maintenance, if authorized by the Maintenance Allocation Chart (MAC) and SMR codes.) This position will contain one of the following maintenance codes:

CODE Application/~~EXPLANATION~~

O - Unit maintenance or Aviation unit is the lowest level that can do complete repair of the item

F - Direct support or aviation intermediate is the lowest level that can do complete repair of the item.

H - General support is the lowest level that can do complete repair of the item.

L - Specialized repair activity is the lowest level that can do complete repair of the item.

D - Depot is the lowest level that can do complete repair of the item.

Z - Nonreparable. No repair is authorized.

B - No repair is authorized. (No parts or special tools are authorized for the maintenance of a "B" coded item). However, the item may be reconditioned by adjusting, lubrication, etc, at the user level.

(3) Recoverability Code. Recoverability codes are assigned to items to indicate the disposition action on unserviceable items. The recoverability code is entered in the fifth position of the SMR Code as follows:

Application/~~Explanation~~

Z - Nonreparable item. When unserviceable, condemn and dispose of the item at the level of maintenance shown in 3d position of the SMR code.

O - Reparable item. When uneconomically reparable, condemn and dispose of the item at unit maintenance or aviation unit level.

F - Reparable item. When uneconomically

reparable, condemn and dispose of the item at the direct support or aviation intermediate level.

H - Reparable item. When uneconomically reparable, condemn and dispose of the item at the general support level

D - Reparable item. When beyond lower level repair capability, return to depot. Condemnation and disposal of item not authorized below depot level.

L - Reparable item. Condemnation and disposal of item not authorized below specialized repair activity (SRA).

A - Item requires special handling or condemnation procedures because of specific reasons (e.g., precious metal content, high dollar value, critical material, or hazardous material). Refer to appropriate manuals/directives for specific instructions.

c. *CAGEC (Column(3))*. The Commercial And Government Entity (CAGE) Code (C) is a 5-digit alphanumeric code which is used to identify the manufacturer, distributor or Government agency, etc., that supplies the item.

d. *PART NUMBER (Column (4))*. Indicates the primary number used by the manufacturer (individual, company, firm, corporation or Government activity), which controls the design and characteristics of the item by means of its engineering drawings, specifications standards and inspection requirements to identify an item or range of items.

NOTE: When you use a NSN to requisition an item, the item you receive may have a different part number from the part ordered.

e. *DESCRIPTION AND USABLE ON CODE (UOC) (Column (5))*. This column includes the following information:

(1) The Federal item name and, when required, a minimum description to identify the item.

(2) Physical security classification. Not applicable.

(3) Items that are included in kits and sets are listed below the name of the kit or set on Figure KIT.

(4) Spare/repair parts that make up and assembled item are listed immediately following the assembled item line entry.

(5) Part numbers for bulk materials are referenced in this column in the line item entry for the item to be manufactured/fabricated.

(6) When the item is not used with all serial numbers of the same model, the effective serial numbers are shown on the last line(s) of the description (before UOC). Not applicable.

(7) The usable on code, when applicable (see paragraph 5, Special information).

(8) In the Special Tools List section, the basis of issue (BOI) appears as the last line(s) in the entry for each special tool, special TMDE and other special support equipment. When density of equipments supported exceeds density spread indicated in the basis of issue, the total authorization is increased proportionately.

(9) The statement "END OF FIGURE" appears just below the last item description in Column 5 for a given figure in both Section II and Section III.

f. QTY (Column (6)). The QTY (quantity per figure column) indicates the quantity of the item used in the breakout shown on the illustration figure, which is prepared for a functional group, subfunctional group or an assembly. A "V" appearing in this column in lieu of a quantity indicates that the quantity is variable and the quantity may vary from application to application.

4. Explanation of Columns (Section IV).

a. NATIONAL STOCK NUMBER (NSN) INDEX.

(1) STOCK NUMBER column. This column lists the NSN by National item identification number (NIIN) sequence. The NIIN consists of the last nine

NSN

digits of the NSN (i.e., 5305-01-674-1467)

NIIN

When using this column to locate an item, ignore the first 4 digits of the NSN. However, the complete NSN should be used when ordering items by stock number.

(2) FIG. column. This column lists the number of the Figure where the item is identified/located. The figures are in numerical order in Section II and Section III.

(3) ITEM column. The item number identifies the item associated with the figure listed in the adjacent FIG. column. This item is also identified by the NSN listed on the same line.

b. PART NUMBER INDEX. Part numbers in this index are listed by part number in ascending

alphanumeric sequence (i.e., vertical arrangement of letter and number combination which places the first letter or digit of each group in order A through Z, followed by the numbers O through 9 and each following letter or digit in like order.)

(1) CAGEC column. The Commercial And Government Entity (CAGE) Code (C) is a 5 digit alphanumeric code used to identify the manufacturer, distributor or Government agency, etc., that supplies the item.

(2) PART NUMBER column. Indicates the primary number used by the manufacturer (individual, firm, corporation or Government activity), which controls the design and characteristics of the item by means of its engineering drawings, specifications standards, and inspection requirements to identify an item or range of items.

(3) STOCK NUMBER column. This column lists the NSN for the associated part number and manufacturer identified in the PART NUMBER and CAGEC columns to the left.

(4) FIG. column. This column lists the number of the figure where the item is identified/located in Section II and III.

(5) ITEM column. The item number is that number assigned to the item as it appears in the figure referenced in the adjacent figure number column.

c. FIGURE AND ITEM NUMBER INDEX.

(1) FIG. column. This column lists the number of the figure where the item is identified/located in Section II and III.

(2) ITEM column. The item number is that number assigned to the item as it appears in the figure referenced in the adjacent figure number column.

(3) STOCK NUMBER column. This column lists the NSN for the item.

(4) CAGEC column. The Commercial And Government Entity (CAGE) Code (C) is a 5 digit alphanumeric code used to identify the manufacturer, distributor or Government agency, etc., that supplies the item.

(5) PART NUMBER column. Indicates the primary number used by the manufacturer (individual, firm, corporation or Government activity), which controls the design and characteristics of the item by means of its engineering drawings, specifications standards and inspection requirements to identify an item or range of items.

5.Special Information.

Use the following subparagraphs as applicable:

a. *USABLE ON CODE.* The usable on code appears in the lower left corner of the Description Column heading. Usable on codes are shown as "UOC: in the Description Column (justified left) on the first line following applicable item description/nomenclature. Uncoded items are applicable to all models. Identification of the usable on codes used in the RPSTL are:

<u>Code</u>	<u>Used On</u>
HE1	MF510B
HE2	10560M
HE3	10560C24
HE5	MF60A-24V
HE6	V7S
HE7	MF510C
HE7	MF60B-24V
HE8	I0560M24B1
H10	1056OG

b. *FABRICATION INSTRUCTIONS.* Bulk materials required to manufacture items are listed in the Bulk Material Functional Group of this RPSTL. Part numbers for bulk materials are also referenced in the description column of the line item entry for the item to be manufactured/fabricated. Detailed fabrication instructions for items source coded to be manufactured or fabricated are found in the appropriate appendices of this manual.

c. *ASSEMBLY INSTRUCTION.* Detailed assembly instructions for items source coded to be assembled from component spare/repair parts are found in the appropriate appendices of this manual. Items that make up the assembly are listed immediately following the assembly item entry or reference is made to an applicable figure.

d. *Kits.* Line item entries for repair parts kits appear in group 9401 in Section II.

e. *INDEX NUMBERS.* Items which have the word BULK in the figure column will have an index number shown in the item number column. This index number is a cross-reference between the National Stock Number/Part Number Index and the bulk material list in Section II.

6. How to Locate Repair Parts.

a. *When National Stock Number or Part Number is Not Known.*

(1) First. Using the table of contents, determine the assembly group or subassembly group to which the item belongs. This is necessary since figures are prepared for assembly groups and subassembly groups, and listings are divided into the some groups.

(2) Second. Find the figure covering the assembly group or subassembly group to which the item belongs.

(3) Third. Identify the item on the figure and use the Figure and Item Number Index to find the NSN.

b. *When National Stock Number or Part Number is Known.*

(1) First. Using the National Stock Number or the Part Number Index, find the pertinent National Stock Number or Part Number. The NSN index is in National Item Identification Number (NIIN) sequence (see 4.a(l)). The part numbers in the Part Number index are listed in ascending alphanumeric sequence (see 4. b). Both indexes cross-reference you to the illustration/figure and item number of the item you are looking for.

(2) Second. Turn to the figure and item number, verify that the item is the one you're looking for, then locate the item number in the repair parts list for the figure.

7. Abbreviations.

For standard abbreviations see MIL-STD-1 2D, Military Standard Abbreviations For Use On Drawings, Specifications, Standards And In Technical Documents.

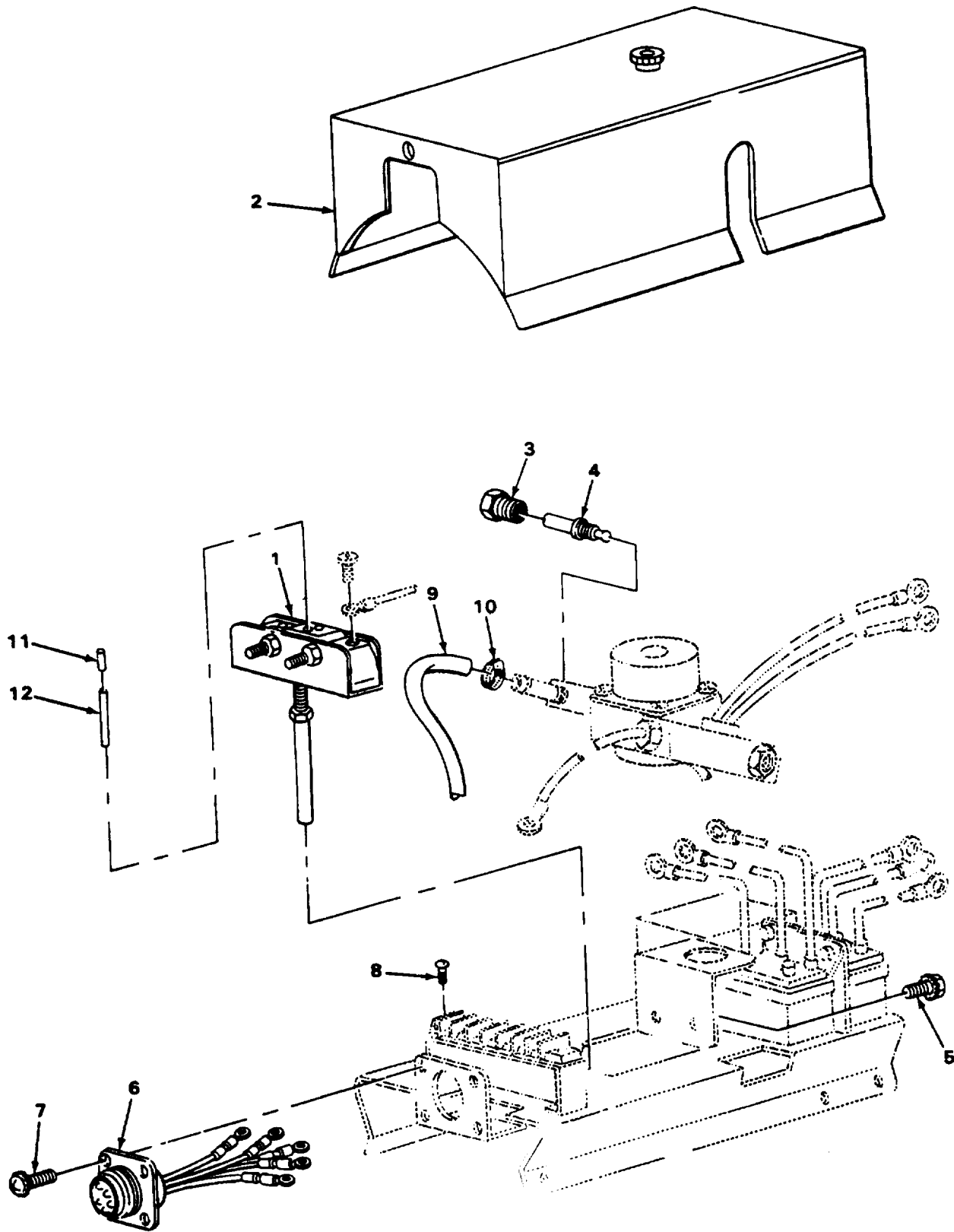

FIGURE 1. HUPP MODEL FLAME DETECTOR SWITCH AND COVER.

SECTION II			TM9-2540-205-24&P		
(1)	(2)	(3)	(4)	(5)	(6)
ITEM NO	SMR CODE	CAGEC	PART NUMBER	DESCRIPTION AND USABLE ON CODES (UOC)	QTY
GROUP 22 BODY, CHASSIS AND HULL ACCESSORY ITEMS					
GROUP 2202 ACCESSORY ITEMS					
FIG. 1 HUPP MODEL FLAME DETECTOR SWITCH AND COVER					
1	PAOZZ	19207	8376101	SWITCH, SENSITIVE UOC:HE1, HE5, HE7	1
2	PAOZZ	46522	C54932-G1-1	COVER ASSEMBLY, CONT UOC:HE1, HE5, HE7	1
3	PAOZZ	6N299	0920416	PLUG, PIPE UOC:HE1, HE5, HE1	1
4	PAOZZ	46522	A18167G2	NOZZLE ASSEMBLY, FIL UOC:HE1, HE5, HE7	1
5	PAFZZ	46522	2251-0832-06-17	SCREW LOCKWASHER UOC :HE1, HE5, HE7	1
6	PAFZZ	46522	B52809G1	CONNECTOR, RECEPTACL UOC:HE1, HE5, HE7	1
7	PAFZZ	07639	A7471-4	SCREW, ASSEMBLED W A S UOC:HE1, HE5, HE7	4
8	PAFZZ	46522	2010-0832-08-13	SCREW CAP ,RCUNDHEAD UOC:HE1, HE5, HE7	2
9	XDFZZ	59556	015-00003-28	HOSE, NONMETALLIC UOC:HE1, HE5, HE7	1
10	PAFZZ	05657	A8	CLAMP, HOSE UOC:HE1, HE5, HE7	2
11	KFOZZ	46522	A50177G1	ROD PART OF KIT P/N 10947055 UOC:HE1, HE5, HE7	1
12	KFOZZ	46522	A50178G1	ROD QUARTZ PART OF KIT P/N 10947055. UOC:HE1, HE5, HE7	1

END OF FIGURE

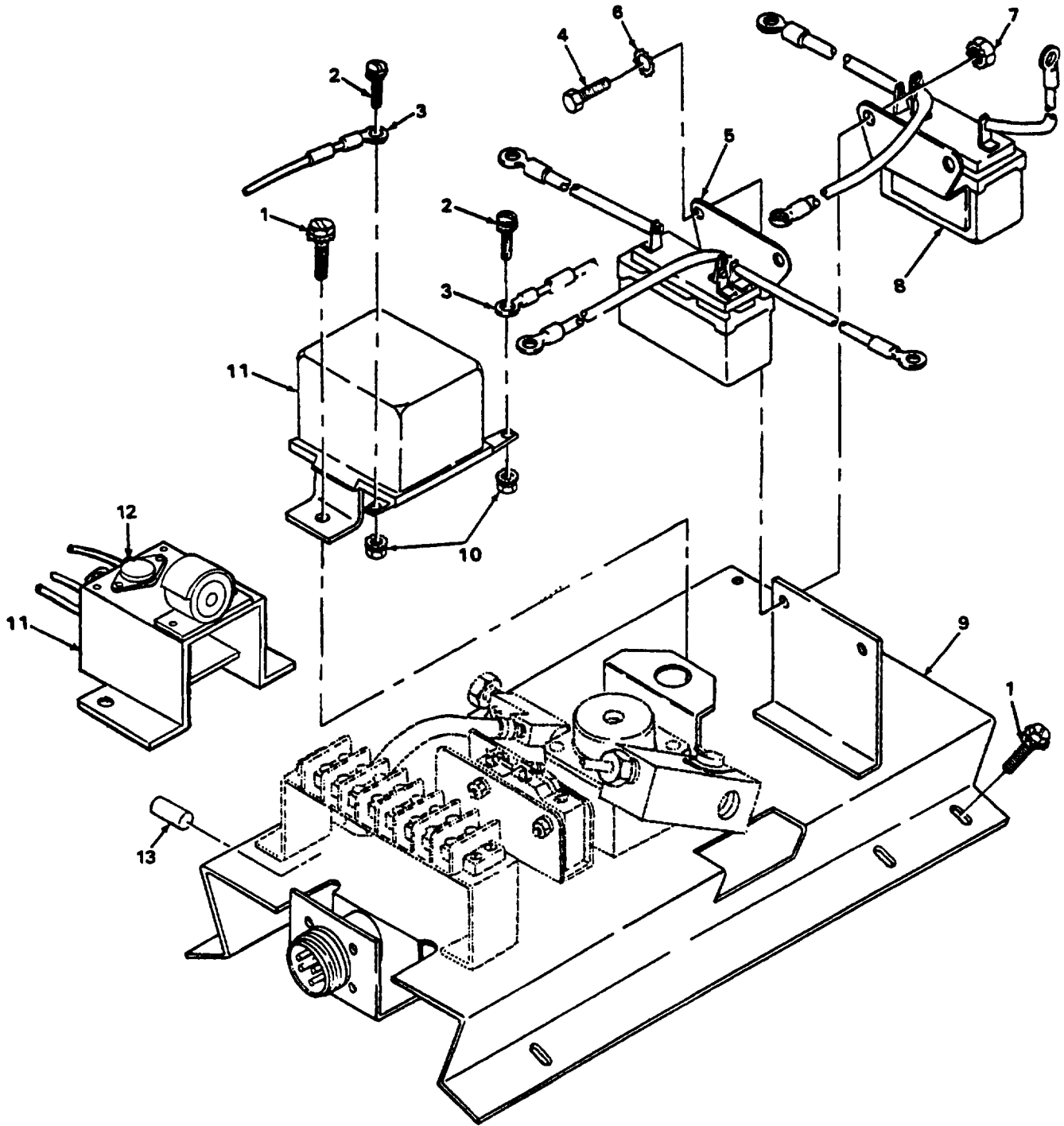

FIGURE 2. HUPP MODEL Hi/LOW FIRE RELAY ASSEMBLY.

SECTION II

TM 9-2540-205-24&P

(1) ITEM NO	(2) SMR CODE	(3) CAGEC	(4) PART NUMBER	(5) DESCRIPTION AND USABLE ON CODES (UOC)	(6) QTY
GROUP 2202 ACCESSORY ITEMS					
FIG. 2 HUPP MODEL HI/LOW FIRE RELAY ASSEMBLY					
1	PAFZZ	11327	3004051	SCREW,MACHINE UOC:HE1, HE5, HE7	6
2	PAFZZ	46522	2060-0632-04-41	SCREW CAP, BINDING UOC:HE1, HE5, HE7	2
3	XBFZZ	46522	B50074-G11-6	WIRE ASSY UOC:HE1, HE5, HE7	2
4	PAFZZ	46522	2251-1032-08-17	SCREW, CAP, HEXAGON UOC:HE1, HE5, HE7	2
5	PAFZZ	46522	B52843G2	RELAY UOC:HE1, HE5, HE7	1
6	PAFZZ	96906	MS35335-32	WASHER, LOCK EXTERNAL TOOTH UOC:HE1, HE5, HE7	2
7	PAFZZ	46522	42-1032-17	NUT, PLAIN, ASSEMBLED UOC:HE1, HE5, HE7	2
8	PAFZZ	19207	8737832	RELAY, VALVE HEATER UOC:HE1, HE5, HE7	1
9	XDFZZ	46522	C54508-G1-1	BRACKET ASSEMBLY UOC:HE1, HE5, HE7	1
10	PAFZZ	46522	42-0632-13	NUT, PLAIN, HEXAGON UOC:HE1, HE5, HE7	2
11	PAFZZ	19207	8737699	RELAY, THERMAL UOC:HE1, HE5, HE7	1
11	PAFZZ	46522	B55304	REGULATOR, VOLTAGE UOC:HE7	1
12	PAFZZ	81349	2N6286	.TRANSISTOR UOC:HE5, HE7	1
13	PAFZZ	46552	A55455-G1	CAPACITOR UOC:HE5, HE7	1

END OF FIGURE

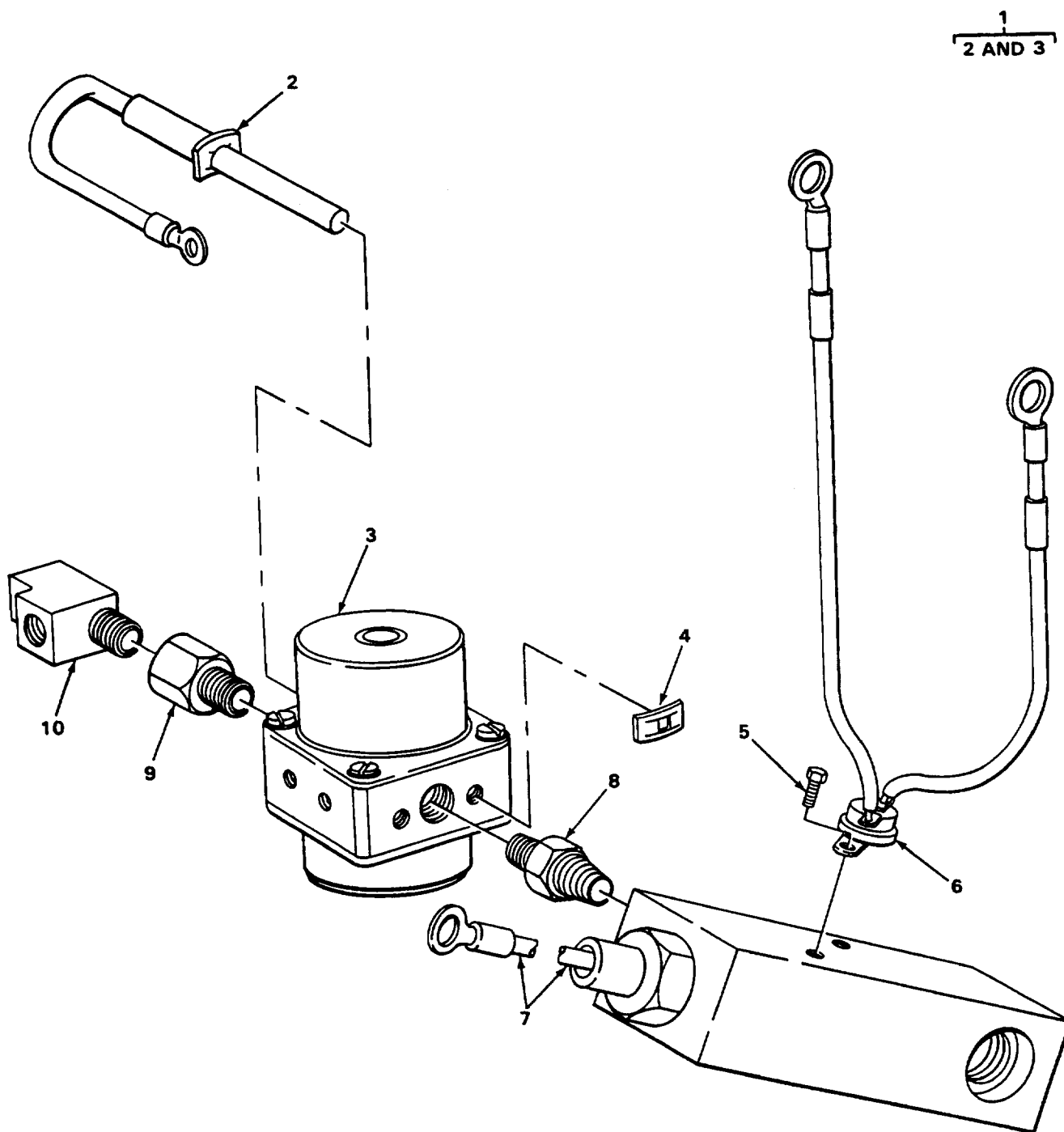

FIGURE 3. HUPP MODEL FUEL REGULATOR VALVE ASSEMBLY.

SECTION 11			TM9-2540-205-24&P			
(1)	(2)	(3)	(4)	(5)	(6)	
ITEM	SMR	CAGEC	PART			
NO	CODE		NUMBER	DESCRIPTION AND USABLE ON CODES (UOC)	QTY	
GROUP 2202 ACCESSORY ITEMS						
FIG. 3 HUPP MODEL FUEL REGULATOR VALVE ASSEMBLY						
1	PAFFF	46522	C552847G1	VALVE, PERSONAL HEA UOC:HE1, HE5, HE7	1	
2	PAFZZ	46522	52850G1	.HEATING ELEMENT,ELE UOC:HE1, HE5, HE7	2	
3	PAFZZ	46522	C52848G1	.VALVE, SOLENDID UOC:HE1,HE5,HE7	1	
4	PAFZZ	46522	30002-83	PUSH ON NUT UOC:HE1,HE5,HE7	2	
5	XDOZZ	46522	2010-0440-02-13	SCREW,MACHINE UOC:HE1, HE5, HE7	2	
6	PADZZ	46522	52876G1	THERMOSTATXFILTER UOC:HE1, HE5 HE7	1	
7	PAFZZ	46522	B543302G1	RESERVOIR ASSEMBLY UOC:HE1, HE5, HE7	1	
8	PAFZZ	88044	AN911-1	NIPPLE, PIPE UOC:HE1,HE5,HE7	1	
9	PAFZZ	30327	68F1-8	ADAPTER, STRAIGHT, PI UOC:HE1,HE5,HE7	1	
10	PAFZZ	46522	A14141	TEE, PIPE TO TUBE UOC:HE1, HE5, HE7	1	

END OF FIGURE

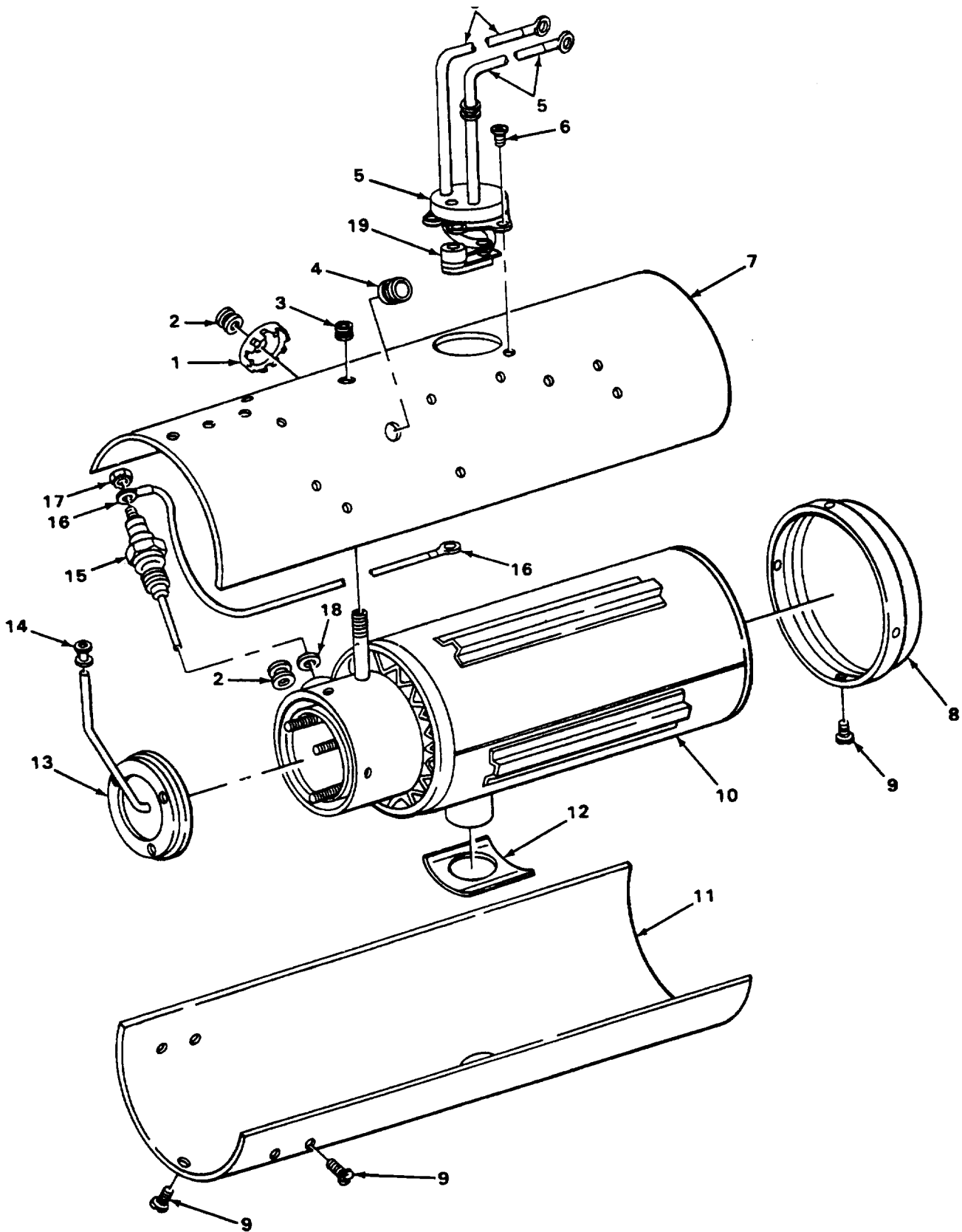

FIGURE 4. HUPP MODEL THERMOSTAT AND COMBUSTION CHAMBER.

SECTION II

TM9-2540-205-24&P

(1) EM	(2) SMR CODE	(3) CAGEC	(4) PART NUMBER	(5) DESCRIPTION AND USABLE ON CODES (UOC)	(6) QTY
0				GROUP 2202 ACCESSORY ITEMS	
				FIG. 4 HUPP MODEL THEPMOSTAT AND COMBUSTION CHAMBER	
1	PAOZZ	46522	A50805G2-3	BUTTON, PLUG UOC:HE1, HE5, HE7	1
2	PAOZZ	46522	50035G2	GROMMET, NONMETALLIC UOC:HE1,HE5,HE7	2
3	PAFZZ	46522	B50035G4	ADAPTER,CAP,HEATER UOC:HE1, HE5, HE7	1
4	PAFZZ	465ZZ	M25000-5	GROMMET,HEATER UOC:HE1,HE5, HE7	1
5	PAFZZ	46522	B52845G1	THERMOSTAT HEATER UOC:HE1,HE5,HE7	1
6	PAFZZ	46522	3310-0832-06-17	SCREW UOC:HE1, HE5, HE7	2
7	XDFZZ	46522	C54823-G1-1	CASING ASSY TOP UOC:HE1,HE7	1
7	XDFZZ	46522	C52833-G1-1	CASING ASSY TOP UOC:HE5	1
8	PAFZZ	46322	C52838G-1	ADAPTER, HEATER CASI UOC:HE1, HE5, HE7	1
9	PAFZZ	11327	3004051	SCREW, MACHINE UOC:HE5	16
9	PAFZZ	46522	2951-1032-06-17	SCREW, MACHINE UOC:HE1,HE7	16
13	XAFZZ	46522	D52812-G1-1	CHAMBER COMBUSTION UOC:HE5	1
10	XAFZZ	46522	D54805-GL-1	CHAMBER ASSY UOC:HE1,HE7	1
11	XDFZZ	44522	C52830-G3-1	ADAPTER ASSEMBLY EX UOC:HE5	1
11	XDFZZ	46522	C54821-G1-1	CASING ASSY BOTTOM UOC:HE1,HE7	1
12	PAFZZ	46522	A52819G1	SEAL UOC:HE5	1
12	PAFZZ	46522	B55075G1	SEAL, EXHAUST TUBE UOC:HE1,HE7	1
13	PAFZZ	46522	52820-G2	PLATE UOC:HE5	1
13	PAFZZ	46522	B55101-G1	PLATE BURNER UOC:HE1,HE7	1
14	PAFZZ	46522	A52364G1	.GROMMET,FUEL TUBE UOC:HE5	1
15	PAOZZ	46522	54733G1	IGNITOR ASSEMBLY UOC:HE1, HE5	1
15	PAOZZ	46522	A55302	IGNITER ASSEMBLY UOC:HE5,HE7	1
16	XDDZZ	46522	B50553-G11-5	WIRE ASSEMBLY IGNITER UOC:HE1,HE5,HE7	1
17	PAOZZ	46522	42-1032-17	NUT,PLAIN,ASSEMBLED	1

SECTION II

TM9-2540-205-2&P

(1) ITEM NO	(2) SMR CODE	(3) CAGEC	(4) PART NUMBER	(5) DESCRIPTION AND USABLE ON CODES (UOC)	(6) QTY
16	PAOZZ	46522	A52342G1	UOC:HE1, HE5, HE7 GASKET	1
19	PAFZZ	46522	52576G1	UOC:HE1, HE5, HE7 SWITCH, THERMOSTATIC	1
				UOC:HE1, HE5, HE7	

END OF FIGURE

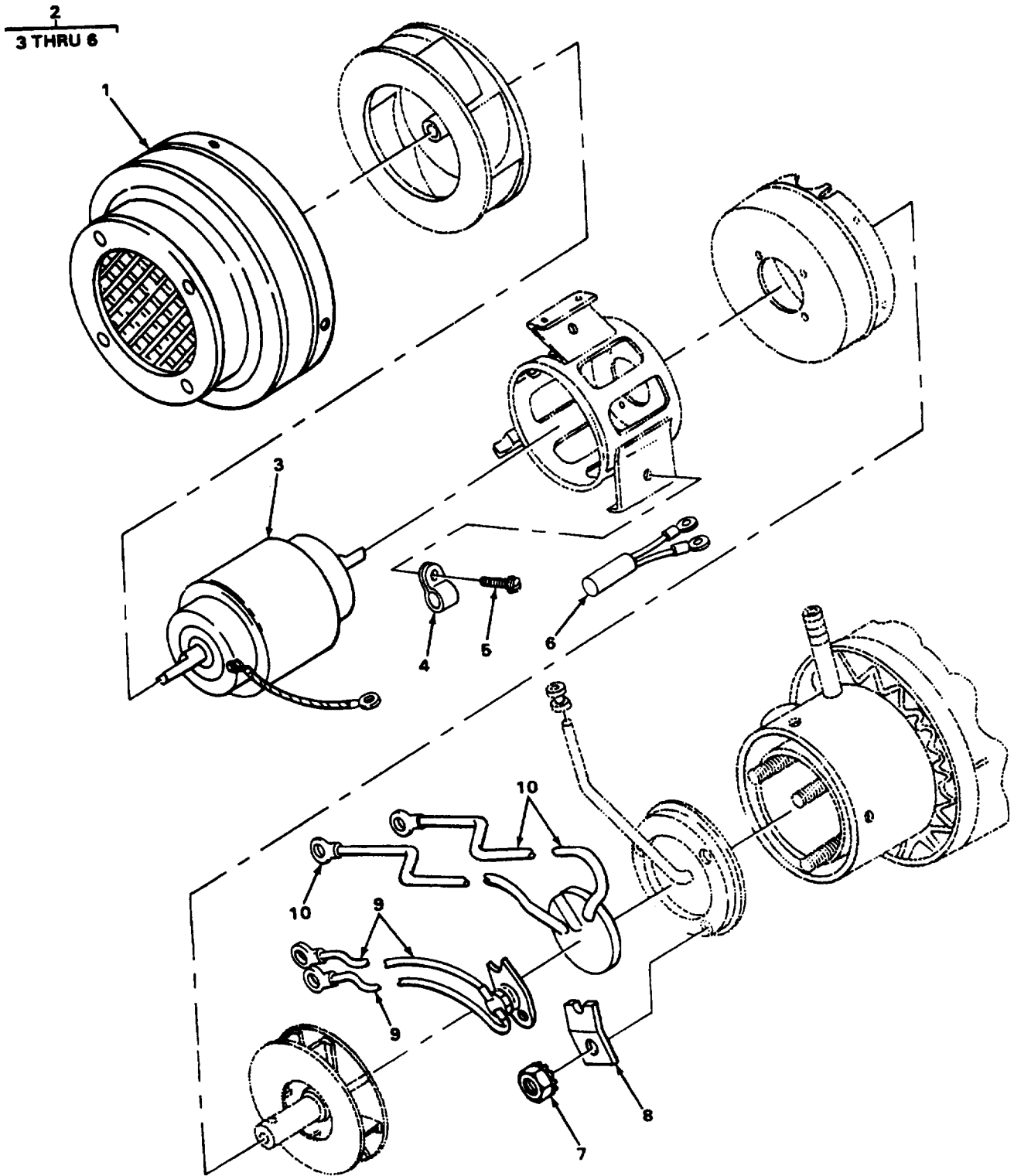

FIGURE 5. HUPP MODEL MF60A-24V PREHEAT ELEMENT, BURNER THERMOSTAT, BLOWER ASSEMBLY AND MOTOR.

ITEM NO	SMR CODE	CAGEC	PART NUMBER	DESCRIPTION AND USABLE ON CODES (UOC)	QTY
GROUP 2202 ACCESSORY ITEMS					
FIG. 5 HUPP MODEL MF80A-24V PREHEAT ELEMENT, BURNER THERMOSTAT, BLOWER ASSEMBLY AND MOTOR					
1	KBFZZ	46522	CS2836G1-1	COVER ASSY INTAKE UOC:HE5	1
2	XBFFF	46522	C52831-G2	BLOWER ASSEMBLY UOC:HE5	1
3	PAFZZ	46522	C16971G2	.MOTOR,DIRECT CURREN UOC:HE5	1
4	XDFZZ	46522	M37001-45	.CLAMP UOC:HE5	2
5	XDFZZ	46522	2251-0832-20-17	.SCREW,HEX,HEAD UOC:HE5	2
6	PAFZZ	46522	54178G2	.RESISTOR,FIXED,WIRE UOC:HE5	1
7	PAFZZ	46522	42-0832-17	NUT, PLAIN, ASSEMBLED UOC:HE5	3
8	PFFZZ	46522	54180G1	BRACKET, THERMOSTAT UOC:HE5	1
9	PAFZZ	46522	52828G1	THERMOSTATXBURNER UOC:HE5	1
10	PAFZZ	19207	11640296	HEATING ELEMENT, ELE PREHEATER UOC:HE5	1

END OF FIGURE

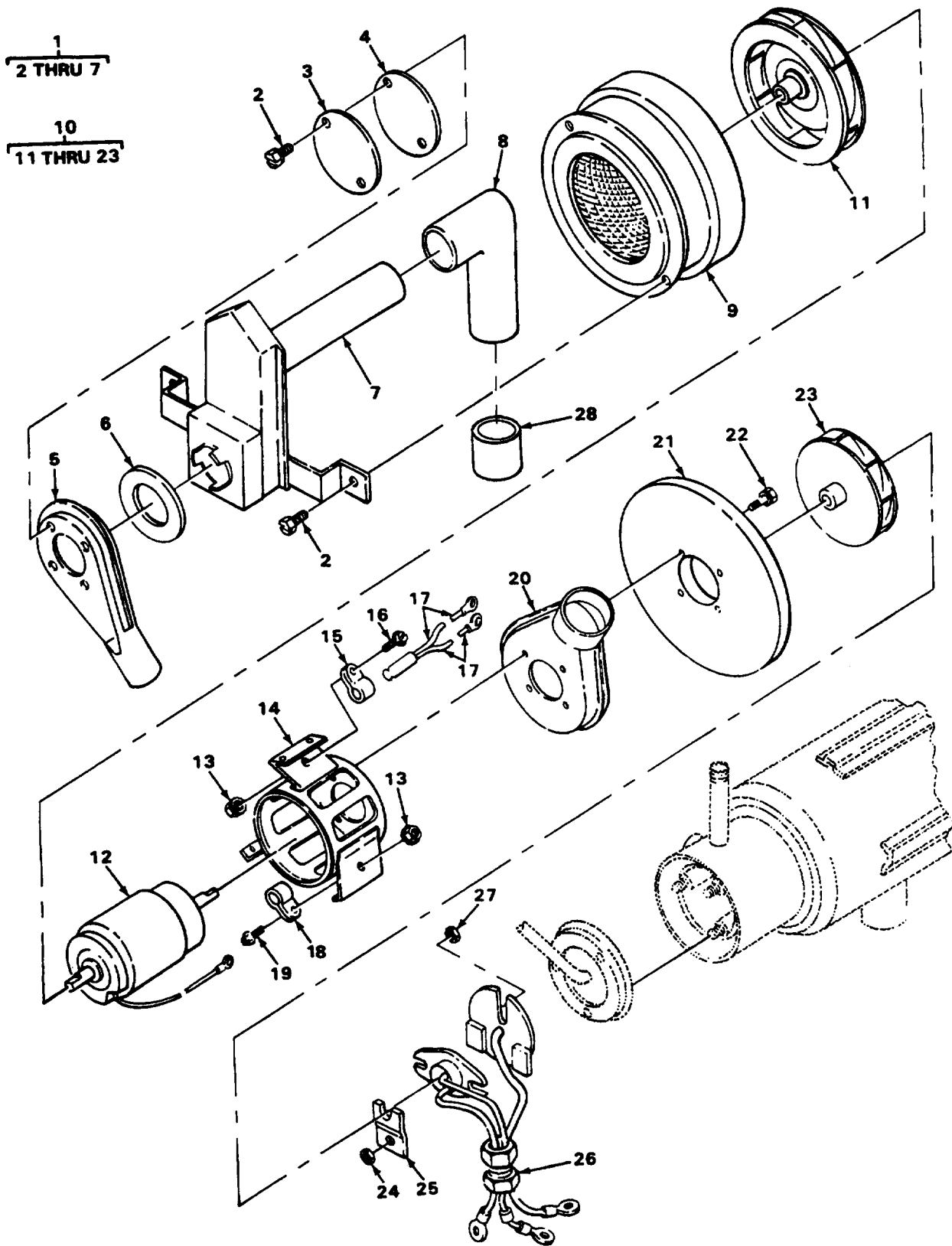

FIGURE 6. HUPP MODELS MF510B, MF510C, MF60B-24V PREHEAT ELEMENT, BURNER THERMOSTAT, BLOWER ASSEMBLY AND MOTOR.

SECTION II

TM9-2540-205-24&P

(1) ITEM NO	(2) SMR CODE	(3) CAGEC	(4) PART NUMBER	(5) DESCRIPTION AND USABLE ON CODES (UOC)	(6) QTY
GROUP 2202 ACCESSORY ITEMS					
FIG. 6 HUPP MODELS MF510B, MF510C, HF60B-24V PREHEAT ELEMENT, BURNER THERMOSTAT, BLOWER ASSEMBLY AND MOTOR					
1	PAFFF	46522	55326-G1	DUC ASSEMBLY UOC:HE1, HE5, HE7	1
2	PAFZZ	44522	2951-1032-06-17	.SCREW,MACHINE UOC:HE1,HE7	4
3	XAFZZ	46522	B54869-G1-1	.PLATE,DUCT UOC:HE1, HE7	1
4	XAFZZ	46522	B54870-G1	.GASKET,DUCT PLATE UOC:HE1,HE7	1
5	XAFZZ	46522	B54859-G2-1	.DUCT ASSY, CCMB, AIR UOC:HE1, HE7	1
6	XDFZZ	46522	A55313-G1	.GASKET,DUCT UOC:HE1, HE7	1
7	XAFZZ	46522	C54868-G1-1	.DUCT, ASSY UOC:HE1, HE7	1
8	PAFZZ	46522	B54936-G1-1	ELBOW,HEATER EXHAUS UOC:HE1, HE7	1
9	XDFZZ	46522	C54807-G1-1	COVER ASSEMBLY INTAKE UOC:HE1,HE7	1
10	PAFFF	46522	C54922-G1	BLOWER ASSEMBLY UOC:HE1, HE7	1
11	PAFZZ	46522	B14658G1-1	.IMPELLER, FAN, CENTRI UOC:HE1, HE7	1
12	PAFZZ	46522	55310-G1	.MOTOR,DIRECT CURREN UOC:HE1, HE7	1
13	PAFZZ	46522	42-0832-17	.NUT,PLAIN,ASSEMBLED UOC:HE1,HE7	2
14	XAFZZ	46522	C17686-G2-2	.SUPPORT ASSY UOC:HE1,HE7	1
15	PAFZZ	46522	M30002-43	.CLAMP UOC:HE1,HE7	1
16	PAFZZ	46522	2251-0832-06-17	.SCREW LOCKWASHER UOC:HE1,HE7	1
17	PAFZZ	46522	B54845G1	.RESISTOR ASSEMBLY UOC:HE1,HE7	1
18	XCFZZ	46522	A50779G1	.CLAMP, LOOP UOC:HE1, HE7	1
19	XDFZZ	46522	2251-0832-08-17	.SCREW ASSEMBLED WASHER UOC:HE1, HE7	1
20	XDFZZ	46522	854859-G1-1	.DUCT ASSY CCMB UOC:HE1,HE7	1
21	PAFZZ	46522	C54804-G1-1	.HOUSING,HEATER ENGI UOC:HE1, HE7	1
22	PAFZZ	46522	2210-0832-20-17	.SCREW,MACHINE UOC:HE1, HE7	4
23	PAFZZ	46522	B54818-G1-1	.FAN ASSY COMBUSTION	1

SECTION II

TM9-2540-205-24&P

(1) ITEM NO	(2) SMR CODE	(3) CAGEC	(4) PART NUMBER	(5) DESCRIPTION AND USABLE ON CODES (UOC)	(6) QTY
24	PAFZZ	46522	42-0832-17	UOC:HE1, HE7 NUT, PLAIN, ASSEMBLED	1
25	PAFZZ	46522	5 4 1 8 0 G 1	UOC:HE1, HE7 BRACKET, THERMOSTAT	1
26	PAFZZ	46522	5 5 1 0 2 - 6 2	UOC:HE1, HE7 ASSEMBLY, THERMOSTAT	1
27	XDFZZ	46522	A55106-G1	UOC:HE1, HE7 NUT	1
28	PAFZZ	46522	A55314-G1	UOC:HE1, HE7 GASKET UOC:HE7	1

END OF FIGURE

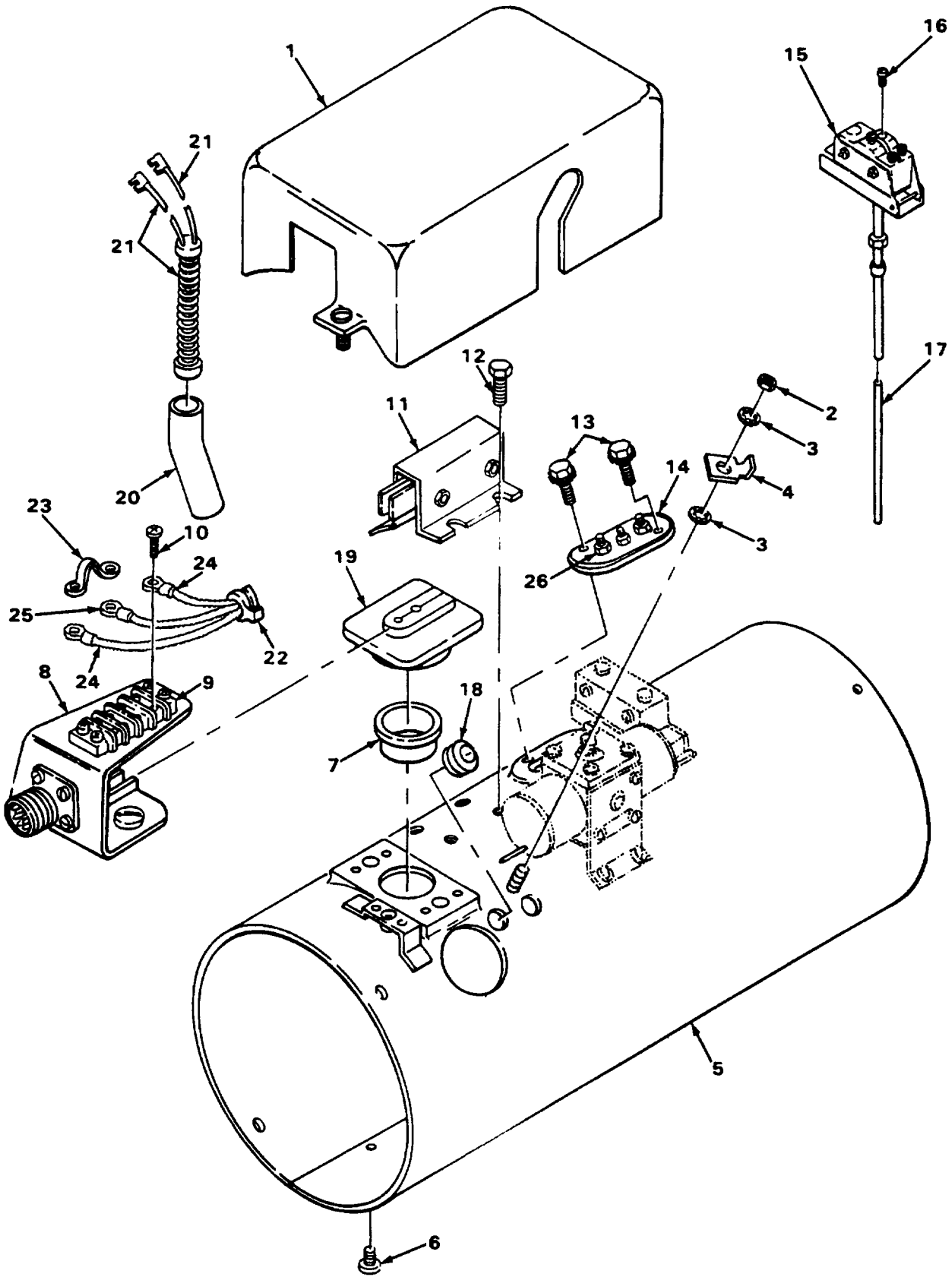

FIGURE 7. STEWART WARNER MODEL IGNITER, FLAME DETECTOR SWITCH, OVERHEAT SWITCH AND IGNITION CONTROL ASSEMBLY.

SECTION II

TM9-2540-205-24&P

(1) ITEM NO	(2) SMR CODE	(3) CAGEC	(4) PART NUMBER	(5) DESCRIPTION AND USABLE ON CODES (UOC)	(6) QTY
GROUP 2202 ACCESSORY ITEMS					
FIG. 7 STEWART WARNER MODEL IGNITER, FLAME DETECTOR SWITCH, OVERHEAT SWITCH AND IGNITION CONTROL ASSEMBLY					
1	PAOZZ	78385	G704625	COVER,ACCESS UOC:HE2,HE8	1
2	PAFZZ	78385	487283	NUT,PLAIN,HEXAGON UOC:HE2, HE8	1
3	PAFZZ	96906	MS45904-57	WASHER,LOCK UOC:HE2, HE8	2
4	PAFZZ	78385	735762	TERMINAL,LUG UOC:HE2, HE8	1
5	PAFZZ	78385	G705030	HOUSING, COMPARTMENT UOC:HE2, HE8	1
6	PAFZZ	57733	170123	SETSCREW UOC:HE2, HE8	3
7	PAOZZ	78385	704667	SEAL,PLAIN ENCASED UOC:HE2, HE8	1
8	PAOZZ	78385	G705362	COVER ASSEMBLY, ECEC UOC:HE2, HE8	1
9	PAOZZ	81349	38TB4	TERMINAL BOARD UDC:HE2,HE8	1
10	PAFZZ	70385	488066	SCREW,ASSEMBLED UOC:HE2, HE8	8
11	PAOZZ	78385	G705353	SWITCH ASSEMBLY, IGN UOC:HE2, HE8, H10	1
12	PAOZZ	96906	MS35206-243	SCREW, MACHINE UOC:HE2, HE8	4
13	PAOZZ	78385	704555	BOLT,ASSEMBLED WASH ASSEMBLED WASHER UOC:HE2, HE8, H10	2
14	PAOZZ	78305	704401	SWITCH, THERMOSTATIC OVERHEAD SWITCH UOC:HE2, HE8, H10	1
15	PAOZZ	78385	G704526	SWITCH, THERMOSTATIC UOC:HE2, HE8	1
16	PAOZZ	96906	MS35206-226	SCREW, MACHINE UOC:HE2,HE8	4
17	PAFZZ	78385	704225	ROD,NCNEXPANSIVE UOC:HE2, HE8, H10	1
18	PAFZZ	79497	KA5BR101	GROMMET, NONMETALLIC UOC:HE2,HE8	1
19	PAOZZ	78385	705356	GROMMET, SPECIAL UOC:HE2, HE8, H10	1
20	PAFZZ	78385	G704288-2	TUBE,HEATER UOC:HE2, HE8	1
21	PAOZZ	16236	CS-4520-SV-0705	IGNITER, SPARK, FUEL UOC:HE2, HE8, H10	1
22	PAFZZ	78385	703129	STRAP,TIEDOWN,ELECT UOC:HE2, HE8	2
23	PAFZZ	78385	700380	CONTACT,ELECTRICAL	1

SECTION II

TM9-2540-205-24&P

(1) ITEM NO	(2) SMR CODE	(3) CAGEC	(4) PART NUMBER	(5) DESCRIPTION AND USABLE ON CODES (UOC)	(6) QTY
24	PAFZZ	78385	G704683	UOC:HE2, HE8, H10 LEAD,ELECTRICAL	1
25	PAFZZ	70385	G704682	UOC:HE2, H10 LEAD,ELECTRICAL	1
26	PAFZZ	78385	480756	UOC:HE2, H10 NUT,PLAIN,ASSEMBLED UOC:H10	2

END OF FIGURE

1
2 THRU 43

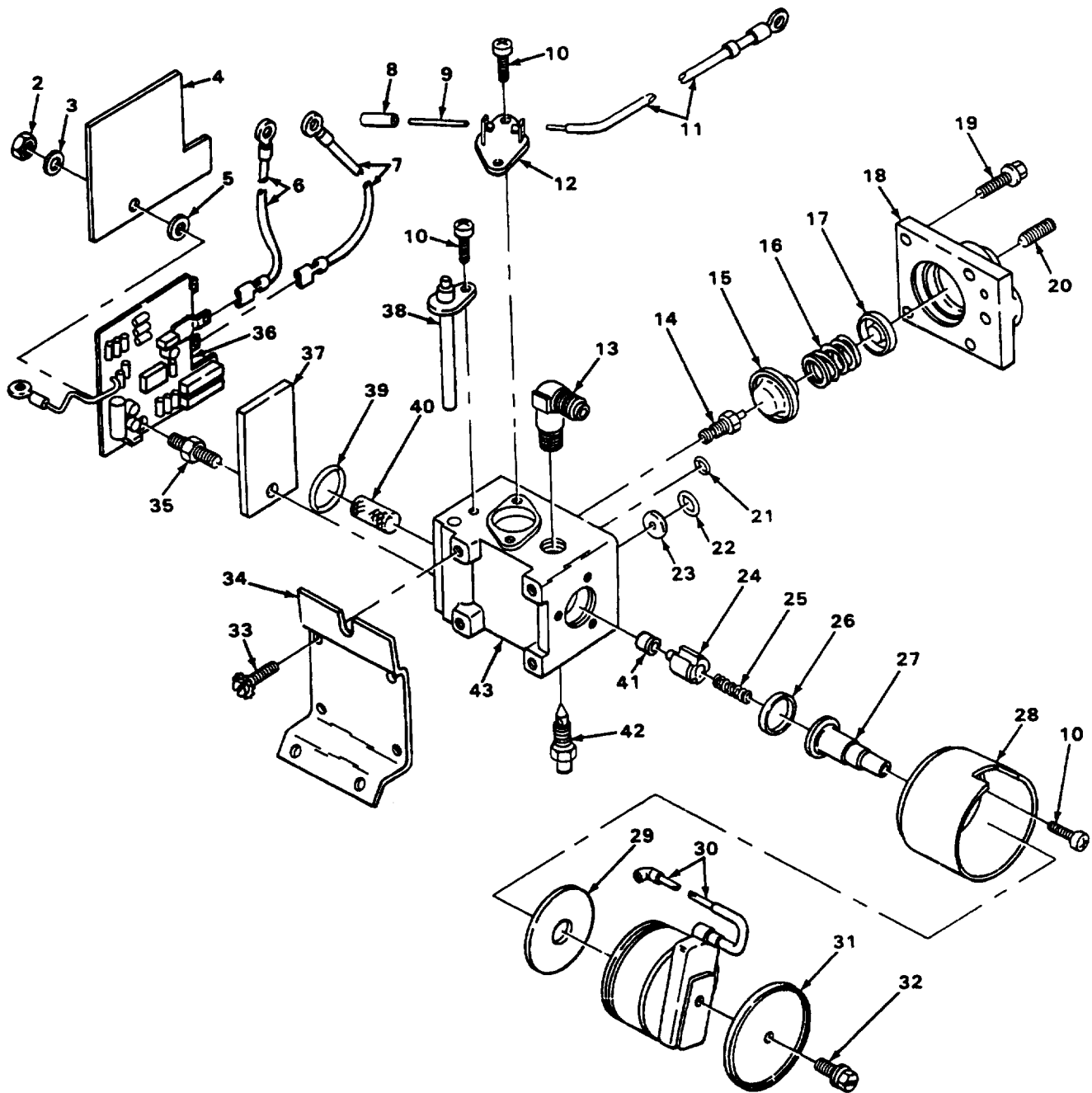

FIGURE 8. STEWART WARNER MODEL FUEL METERING PULSE VALVE.

SECTION II

TM9-2540-205-24&P

(1) ITEM NO	(2) SMR CODE	(3) CAGEC	(4) PART NUMBER	(5) DESCRIPTION AND USABLE ON CODES (UOC)	(6) QTY
GROUP 2202 ACCESSORY ITEMS					
FIG. 8 STEWART WARNER MODEL FUEL METERING PULSE VALVE					
1	PAFFF	78385	G705990	VALVE,FUEL,REGULATI UOC:HE2, HE8, H10	1
2	PAFZZ	96906	MS35649-286	.NUT,PLAIN,HEXAGON UOC:HE2, HE8 H10	2
3	PAFZZ	96906	MS51412-2	.WASHER,FLAT UOC:HE2, HE8, H10	2
4	XDFZZ	70385	705931	.SHIELD,PULSE GENERA UOC:HE2,HE8,H10	1
5	PAFZZ	96906	MS51859-5	.WASHER,FLAT UOC:HE2,HE8,H10	2
6	XBFZZ	78385	G705903-7	.CABLE ASSY UOC:HE2,HE8,H10	1
7	XBFZZ	78385	G705903-5	.CABLE ASSEMBLY UOC:HE2,HE8,H10	1
8	PAOZZ	78385	735447-5	.INSULATION SLEEVING UOC:HE2,HE8,H10	1
9	XBOZZ	78385	704447-1	.WIRE,ELECTRICAL UOC:HE2,HE8,H10	1
10	PAOZZ	78385	704436	.SCREW UOC:HE2,HE8,H10	6
11	PAOZZ	78385	G702562-27	.LEAD,ELECTRICAL UOC:HE2,HE8,H10	1
12	PADZZ	78385	704401	.SWITCH,THERMOSTATIC UOC:HE2,HE8,H10	1
13	PAFZZ	96906	MS39171-12	.ELBOW,PIPE TO TUBE UOC:HE2,HE8,H10	1
14	KFFZZ	78385	720942	.CORE,VALVE PART OF KIT P/N G705954. UOC:HE2,HE8,H10	1
15	KFFZZ	78385	G705850	.DIAPHRAM ASSEMBLY PART OF KIT F/N G705954 UOC:HE2,HE8,H10	1
16	PAFZZ	78385	489209	.SPRING,HELICAL,COMP UOC:HE2,HE8,H10	1
17	PAFZZ	78385	474677	.RETAINER,HELICAL UOC:HE2,HE8,H10	1
18	XDFZZ	78385	705836	.CAP,DIAPHRAGM UOC:HE2,HE8,H10	1
19	PAFZZ	96906	MS51849-55	.SCREW,MACHINE UOC:HE2,HE8,H10	4
20	PAFZZ	78385	7705846	.SCREW,ADJUSTING UOC:HE2,HE8,H10	1
21	PAFZZ	78385	704406	.PACKING,PREFORMED PART OF KIT F/N G705954 UOC:HE2,HE8,H10	1
22	KFFZZ	78385	704883	.PACKING,PREFORMED PART OF KIT P/N G705954 UOC:HE2,HE8,H10	1

SECTION II

TM9-2540-205-24&P

(1) ITEM NO	(2) SMR CODE	(3) CAGEC	(4) PART NUMBER	(5) DESCRIPTION AND USABLE ON CODES (UOC)	(6) QTY
23	XDFZZ	78385	705841	.DRIFICE,FUEL METER I UOC:HE2,HE8,H10	1
24	XBFZZ	78385	705845	.PLUNGER,SOLENOID UOC:HE2,HE8,H10	1
25	PAFZZ	78385	476339	.SPRING,HELICAL,COMP UOC:HE2,HE8,H10	1
26	PAFZZ	57733	474669	.GASKET PART OF KIT P/N G705954 UOC:HE2,HE8,H10	1
27	PAFZZ	78385	G705558	.SLEEVE ASSEMBLY UOC:HE2,HE8,H10	1
28	XAFZZ	78385	705556	CUP,SOLENCID UOC:HE2,HE8,H10	1
29	PAFZZ	78385	474229	.WASHER,FLAT UOC:HE2,HE8,H10	1
30	XDFZZ	78385	G7055989-44	.COIL ASSEMBLY, SOLENOID UOC:HE2,HE8,H10	1
31	PPFZZ	78385	705557-1	.COVER,SOLENDID UOC:HE2,HE8,H10	1
32	PAFZZ	78385	701761	.SCREW,MACHINE UOC:HE2,HE8,H10	1
33	PAFZZ	78385	704435	.SCREW,CAP,HEXAGON UOC:HE2,HE8,H10	4
34	XBFZZ	78385	704431-3	.BRACKET,VALUE MOUNT UOC:HE2,HE8,H10	1
35	PPFZZ	78385	705345	.STUD,PLAIN UOC:HE2,HE8	1
36	PAFZZ	78385	705840	.GENERATOR,PULSE UOC:HE2,HE8,H10	1
37	XDFZZ	78305	705847	.PLATE SEALING UOC:HE2,HE8,H10	1
38	PAFZZ	78385	705843	.HEATING ELEMENT,ELE UOC:HE2,HE8,H10	1
39	PAFZZ	96906	MS9060-115	.PACKING,PREFORMED PART OF KIT P/N G705954 UOC:HE2,HE8,H10	1
40	KFFZZ	78385	705842	.SCREEN,INLET PART OF KIT P/N G705954 UOC:HE2,HE8,H10	1
41	PAFZZ	78385	735411	.SEAL,PLAIN FART OF KIT P/N G705954 UOC:HE2,HE8,H10	1
42	PAFZZ	78305	704575	.STEM,NEEDLE VALVE UOC:HE2,HE8,HE10	1
43	XAFZZ	78385	705838	.BODY,VALVE UOC:HE2,HE8,H10	1

END OF FIGURE

1
2 THRU 17

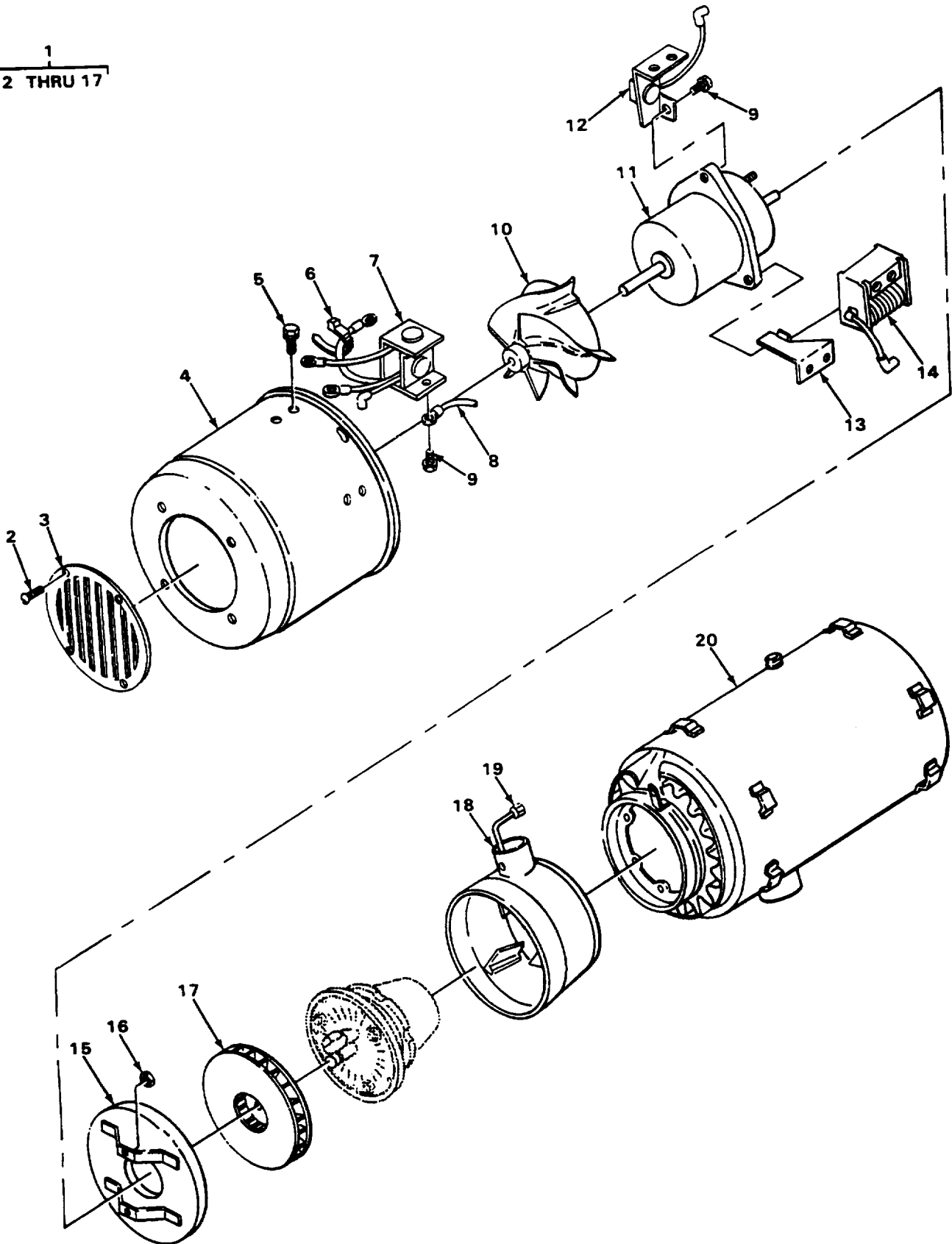

FIGURE 9. STEWART WARNER MODELS 1056OG, 1056OC24 BLOWER ASSEMBLY AND HEAT EXCHANGER.

SECTION II

TM9-2540-205-24&P

(1) ITEM NO	(2) SMR CODE	(3) CAGEC CAGEC	(4) PART NUMBER	(5) DESCRIPTION AND USABLE ON CODES (UOC)	(6) QTY
GROUP 2202 ACCESSORY ITEMS					
FIG. 9 STEWART WARNER MODELS 10560G, 10560C24 BLOWER ASSEMBLY AND HEAT EXCHANGER					
1	XAFFF	78385	G706144	BLOWER ASSEMBLY UOC:H10	1
1	XAFFF	78385	G705225	BLOWER ASSEMBLY UOC:HE3	1
2	PAFZZ	96906	MS35206-243	.SCREW,MACHINE UOC:HE3,H10	4
3	PAFZZ	78385	488773	.VENTILATOR,AIR CIRC UOC:HE3,H10	1
4	PAFZZ	78385	G706166	.HOUSING HEATER BLOW UOC:H10	1
4	PAFZZ	78385	G705102	.HOUSING,HEATER BLOW UOC:HE3	1
5	XDFZZ	78385	CONL	.SCREW ASSY WASHER UOC:HE3,H10	10
6	PAFZZ	78385	703129	.STRAP,TIEDOWN,ELECT UOC:HE3,H10	1
7	PAFZZ	78385	G706159	.SEMICONDUCTOR DEVIC UOC:HE3,H10	1
7	PAFZZ	78385	G705241	.SEMICONDUCTOR UOC:HE3	1
8	PAFZZ	78385	701226-24	.LEAD,ELECTRICAL UOC:HE3,H10	2
9	PAFZZ	96906	MS51849-53	.SCREW,MACHINE UOC:HE3,H10	3
10	XBFZZ	78385	G704974	.WHEEL ASSEMBLY UOC:HE3,H10	1
11	PAFZZ	78385	G706149	.MOTOR,DIRECT CURREN UOC:H10	1
11	PAFZZ	78385	G704557	.MOTOR,DIRECT CURREN UOC:HE3	1
12	XBFZZ	78385	G705230	.BRACKET, CABLE UOC:HE3,H10	1
13	XBFZZ	78385	705236	.BRACKET HEATER UOC:HE3,H10	2
14	PAFZZ	19207	11669574	.VOLTAGE REGULATOR UOC:HE3,H10	1
15	PAFZZ	78385	G700749	.COVER ASSY,BLOWER UOC:HE3,H10	1
16	PAFZZ	96906	MS35649-282	.NUT,PLAIN,HEXAGON UOC:HE2,HE3,HE8,H10	2
17	PAFZZ	57733	G706147	.IMPELLER FAN CENTRI UOC:H10	1
17	PAFZZ	57733	G489276	.IMPELLER,FAN,CENTRI UOC:HE3	1
18	PBFZZ	78385	G704656	HOUSING,HEATER BLOW UOC:HE3,H10	1

SECTION II

TM 9-2540-205-24&P

(1) ITEM NO	(2) SMR CODE	(3) CAGE	(4) PART NUMBER	(5) DESCRIPTION AND USABLE ON CODES(UOC)	(6) QTY
19	PAFZZ	78385	104635	TUBE ASSEMBLY,METAL UOC:HE2,HE3,HE8,H10	1
20	XAFZZ	78385	G704612	HEAT EXCHANGEC ASSE UOC:HE3,H10	1

END OF FIGURE

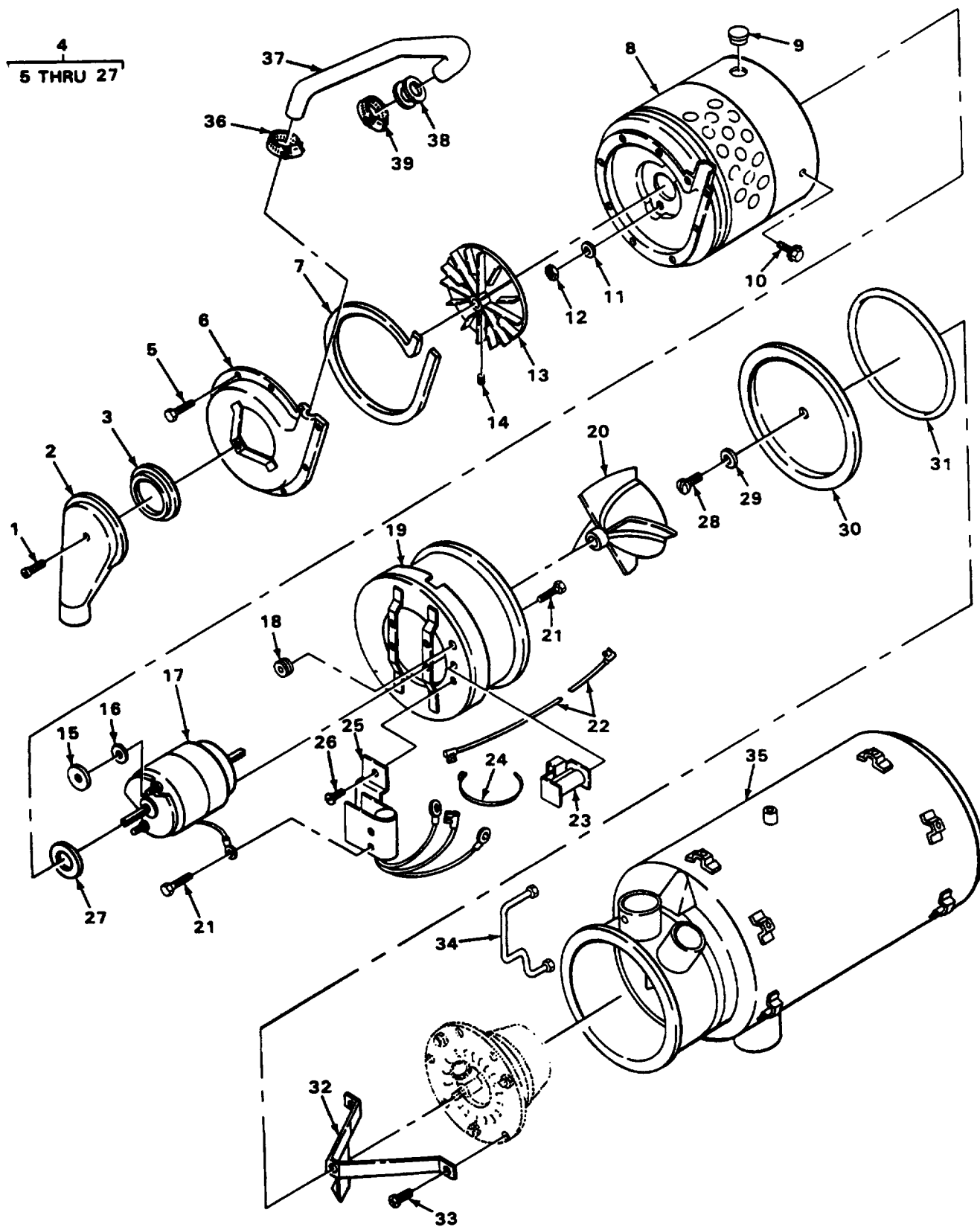

FIGURE 10. STEWART WARNER 10560M, 10560M24B1 BLOWER ASSEMBLY AND HEAT EXCHANGER.

SECTION II

TM9-2540-205-24&P

(1) ITEM NO	(2) SMR CODE	(3) CAGEC	(4) PART NUMBER	(5) DESCRIPTION AND USABLE ON CODES (UOC)	(6) QTY
GROUP 2202 ACCESSORY ITEMS					
FIG. 10 STEWART WARNER 10560M 10560M24B1 BLOWER ASSEMBLY AND HEAT EXCHANGER					
1	PAFZZ	96906	MS35273-44	SCREW UOC:HE2,HE8,H10	1
2	PAFZZ	78385	G738396	ADAPTER, INLET UOC:HE2,HE8	1
3	PAFZZ	78385	738448	GROMMET, NONMETALLIC UOC:HE2,HE8	1
4	AFFFF	78385	G703294-1	BLOWER ASSEMBLY UOC:HE2,HE8	1
5	PAFZZ	78385	488066	.SCREW, ASSEMBLED WAS UOC:HE2,HE8	9
6	PAFZZ	78385	G705300	.HOUSING, BLOWER ASSE UOC:HE2,HE8	1
7	PAFZZ	78385	704980	.GASKET UOC:HE2,HE8	1
8	XAFZZ	78385	G705293	.HOUSING, BLOWER UOC:HE2,HE8	1
9	PAFZZ	78385	722058	.PLUG, PROTECTIVE, DUS UOC:HE2,HE8	1
13	PAFZZ	78385	704555	.BOLT, ASSEMBLED WASH UOC:HE2,HE8,H10	2
11	PAFZZ	96906	MS27183-41	.WASHER, FLAT UOC:HE2,HE8	2
12	PAFZZ	96906	MS35649-282	.NUT, PLAIN, HEXAGON UOC:HE2,HE3,HE8,H10	2
13	PAFZZ	78385	738460-2	.WHEEL, COMBUSTION BL UOC:HE2,HE8	1
14	XDFZZ	57733	700042	.SCREW, SET UOC:HE2,HE8	1
15	PAFZZ	78385	705692	.GASKET UOC:HE2,HE8	2
16	PAFZZ	78385	704190	.WASHER UOC:HE2,HE8	2
17	PAFZZ	78385	G705319-1	.MOTOR, DIRECT CURREN UOC:HE2,HE8	1
18	PAFZZ	92872	3191	.GROMMET, NONMETALLIC UOC:HE2,HE8,HE10	1
19	XAFZZ	78385	G705292	.HOUSING, VENT AIR UOC:HE2,HE8	1
20	PAFZZ	78385	G705368	.WHEEL, VENT BLOWER UOC:HE2,HE8	1
21	XDFZZ	70385	719676	.SCREW, CAP, HEXAGON HEAD UOC:HE2,HE8	5
22	PAFZZ	78385	G705377	.CABLE ASSEMBLY, SPEC UOC:HE2,HE8	1
23	PAFZZ	78385	G705320	.REGULATOR, CURRENT UOC:HE2,HE8	1

SECTION II

TM9-2540-205-24&P

(1) ITEM NO	(2) SMR CODE	(3) CAGEC	(4) PART NUMBER	(5) DESCRIPTION AND USABLE ON CODES (UOC)	(6) QTY
23	PAFZZ	78385	G706157	.REGULATOR, VOLTAGE UOC:H10	1
24	PAFZZ	78385	703129	.STRAP,TIEDOWN,ELECT UOC:HE2,HE8	3
25	PAFZZ	78385	G705315	.MOUNTING ASSEMBLY,D UOC:HE2,HE8	1
26	PAFZZ	57733	170123	.SET SCREW UOC:HE2,HE8	4
27	PAFZZ	78385	705691	.GASKET UOC:HE2,HE8	1
28	XCFZZ	78385	170315	SCREW UOC:HE2,HE8	1
29	PAFZZ	96906	MS27183-9	WASHER,FLAT UOC:HE2,HE8,H10	1
30	PAFZZ	78385	705340	CAP,ADAPTER UOC,HE2,HE8	1
31	PAFZZ	78385	730050-2	PACKING,PREFORMED UOC:HE2,HE8	1
32	PAFZZ	78385	G705065	BRACKET,MOUNTING,HE UOC:HE2,HE8	1
33	PAFZZ	78385	705032	SCREW UOC:HE2,HE8	2
34	PAFZZ	78385	704635	TUBE ASSEMBLY,METAL UOC:HE2,HE3,HE8,H10	1
35	PAFZZ	78385	G705341	HEAT EXCHANGER ASSE UOC:HE2,HE8	1
36	PAFZZ	78385	705640-1	CLAMP,LOOP UOC:HE2,HE8	1
37	PAFZZ	78385	738457	HOSE,AIR DUCT UOC:HE2,HE8	1
38	PAFZZ	78385	736641	GROMMET,NONMETALIC UOC:HE2,HE8	1
39	PAFZZ	78385	705640-2	CLAMP,LOOP UOC:HE2,HE8	1

END OF FIGURE

1
2 THRU 14

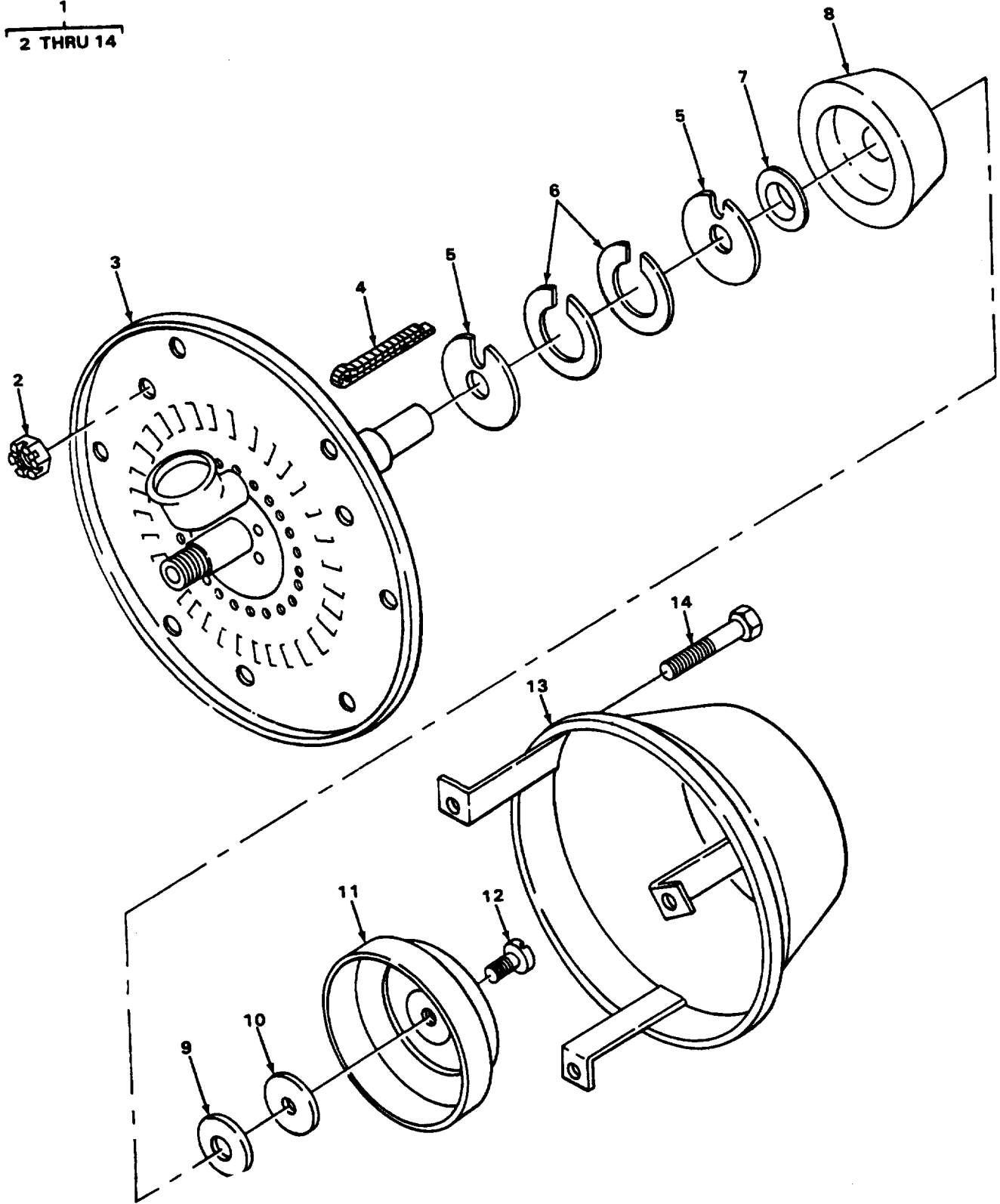

FIGURE 11. STEWART WARNER MODEL BURNER ASSEMBLY.

SECTION 11

TM 9-2540-205-24&P

(1) ITEM NO	(2) SMR CODE	(3) CAGEC	(4) PART NUMBER	(5) DESCRIPTION AND USABLE ON CODES (UOC)	(6) QTY
GROUP 2202 ACCESSORY ITEMS					
FIG. 11 STEWART WARNER MODEL BURNER ASSEMBLY					
1	KFFFF	78385	G705081	BURNER ASSEMBLY,SPA PART OF KIT P/N G704528 UOC:HE2,HE8,H10	1
2	PAFZZ	96906	MS21043-08	.NUT,SELF-LOCKING,EX PART OF KIT P/N G704528 UOC:HE2,HE8,H10	3
3	PAFZZ	78385	G705080	.PLATE AND BUSING A PART OF KIT P/N G704528 UOC:HE2,HE8,H10	1
4	PAFZZ	19207	11663062-1	.WICK PART OF KIT P/N G704528 UOC:HE2,HE8,H10	1
5	PAFZZ	70385	705078	.WASHER PART OF KIT P/N G704528 UOC:HE2,HE8,HE10	2
6	KFFZZ	78385	705136	.WASHER PART OF KIT P/N G704528 UOC:,HE2,HE8,H10	2
7	PAFZZ	78385	705135	.WASHER,SHOULDERED PART OF KIT P/N G704528 UOC:HE2,HE8,H10	1
8	KFFZZ	78385	705079	.VAPORIZER,FUEL PART OF KIT P/N G704528 UOC:HE2,HE8,H10	1
9	PAFZZ	78385	705116	.WASHER PART OF KIT P/N G704528 UOC:HE2,HE8,H10	1
10	KFFZZ	78385	704190	.WASHER PART OF KIT P/N G704528 UOC:HE2,HE8,H10	1
11	PAFZZ	78385	704423	.SHIELD,FUEL VAPORIZ PART OF KIT P/N G704528 UOC:HE2,HE8,H10	1
12	PAFZZ	78385	705117	.SCREW,MACHINE PART OF KIT P/N G704528 UOC:HE2,HE8,H10	1
13	KFFZZ	78385	G705209	.CUP AND LEG ASSY PART OF KIT P/N G704528 UOC:HE2,HE8,HE10	1
14	PAFZZ	78385	705032	.SCREW PART OF KIT P/N G704528 UOC:HE2,HE8,H10	3

END OF FIGURE

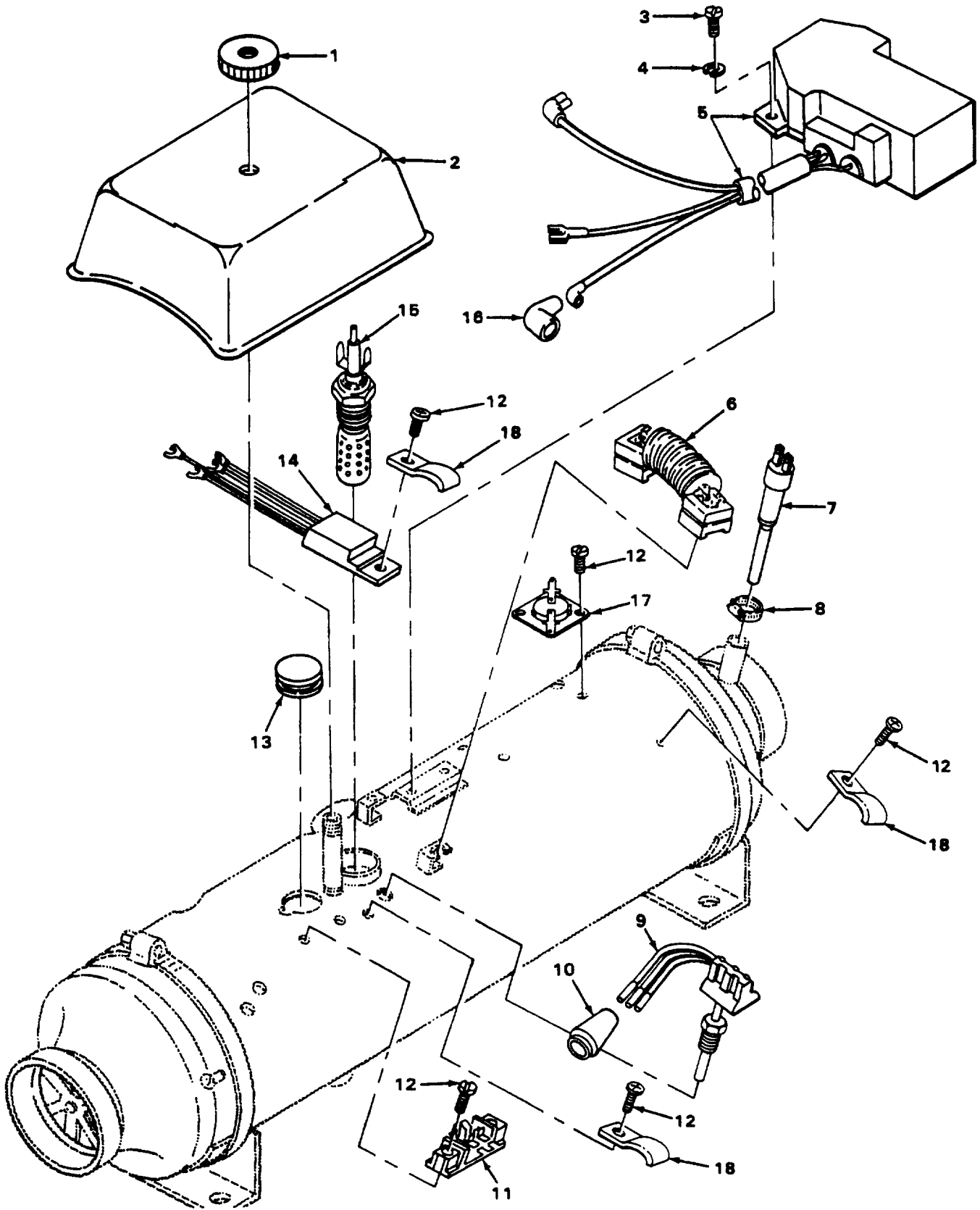

FIGURE 12. ESPar MODEL V7S SPARK GENERATOR, RESISTOR, GLOW PLUG, TEMPERATURE SENSOR AND SWITCH.

SECTION II

TM9-2540-205-24&P

(1) ITEM NO	(2) SMR CODE	(3) CAGEC	(4) PART NUMBER	(5) DESCRIPTION AND USABLE ON CODES (UOC)	(6) QTY
GROUP 2202 ACCESSORY ITEMS					
FIG. 12 ESPAR MODEL V7S SPARK GENERATOR, RESISTOR, GLOW PLUG, TEMPERATURE SENSOR AND SWITCH					
1	PAFZZ	D8435	201144260003	NUT,PLAIN,KNURLED UOC:HE6	1
2	PAFZZ	D8435	251244010003	PROTECTIVE CAP UOC:HE6	1
3	PAFZZ	D8046	007985005127	SCREW,MACHINE UOC:HE6	2
4	PAFZZ	D8435	171 22 084	WASHER,LOCK UOC:HE6	2
5	PAFZZ	D8435	25 1447 01 04 00	SPARK GENERATOR IGN UOC:HE6	1
6	PAFZZ	D8435	25 1244 01 05 00	RESISTOR,FIXED,WIRE UOC:HE6	1
7	PAFZZ	D8435	20 1348 03 00 32	SENSOR,TEMPERATURE UOC:HE6	1
8	PAFZZ	D8773	S10/92Y	CLAMP,HOSE UOC:HE6	1
9	PAFZZ	D8435	25 1244 99 35 00	SWITCH,THERMOSTATIC UOC:HE6	1
10	PAFZZ	D8512	925075	.CONNECTOR BODY,PLUG UOC:HE6	1
11	PAFZZ	D8435	25 1214 15 09 00	TERMINAL BOARD UOC:HE6	1
12	PAFZZ	D8435	108 10 323	SCREW,TAPPING,THREA UOC:HE6	6
13	PAFZZ	D8435	20 1101 01 00 05	GROMMET BLANK,NONME UOC:HE6	1
14	PAFZZ	D8435	25 1244 01 06 00	CAPACITOR,FIXED,PAP UOC:HE6	1
15	PAFZZ	D8435	25 1431 01 00 03	SPARK PLUG GLOW UOC:HE6	1
16	PAFZZ	D8435	206 00 150	SPARK PLUG SOCKET UOC:HE6	1
17	PAFZZ	D8435	25 1244 01 07 00	SWITCH,THERMOSTATIC OVERHEAT SWITCH UOC:HE6	1
18	PAFZZ	D8773	DIN72571-1X7-ST- VERZINKT	STRAP,RETAINING UOC:HE6	3

END OF FIGURE

1
2 THRU 12

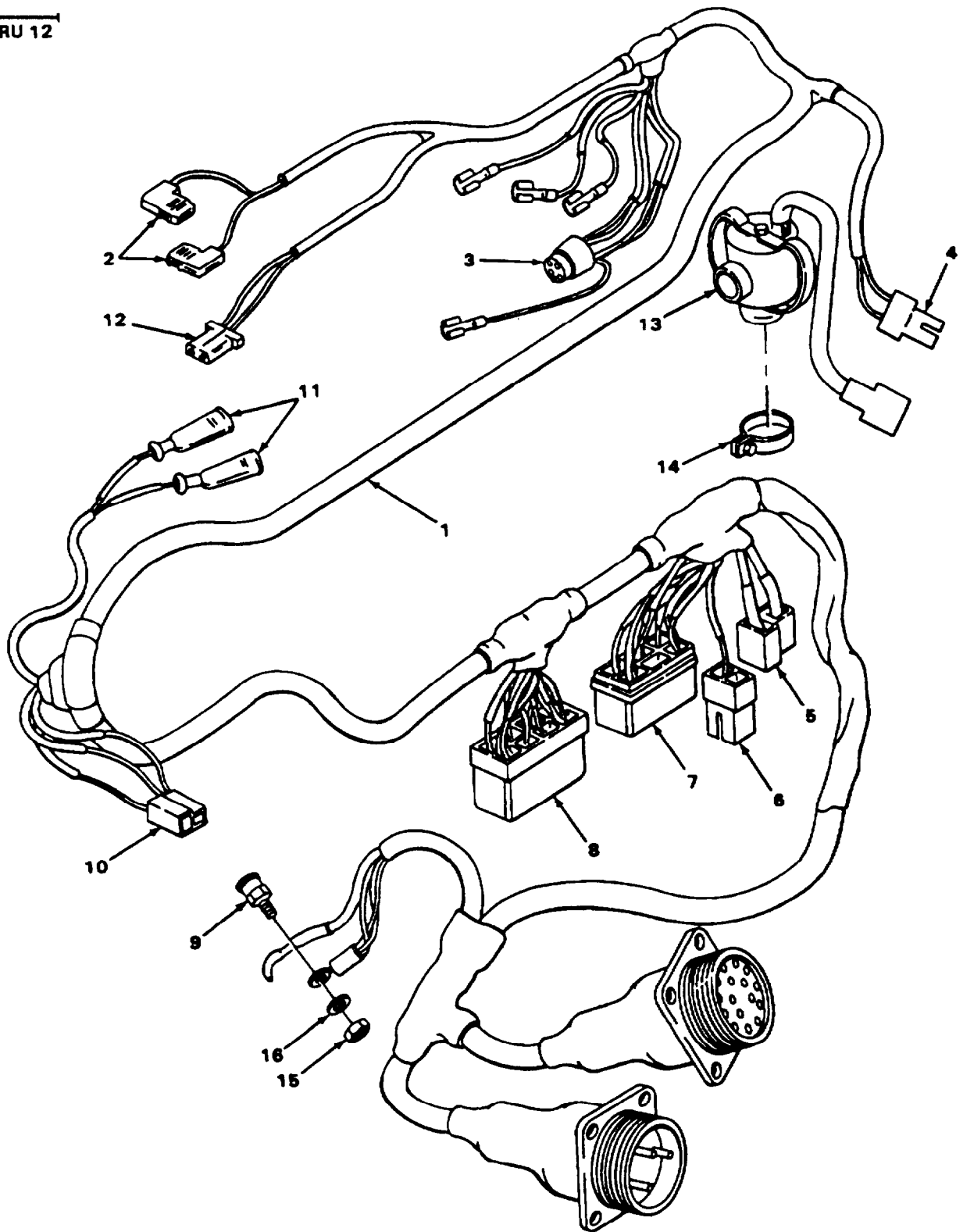

FIGURE 13. ESPAR MODEL V7S AIR SOLENOID VALVE AND WIRING HARNESS.

SECTION 11			TM9-2540-205-24&P			
(1)	(2)	(3)	(4)		(5)	(6)
ITEM	SMR	CAGEC	PART		DESCRIPTION AND USABLE ON CODES (UOC)	QTY
NO	CODE		NUMBER			
GROUP 2202 ACCESSORY ITEMS						
FIG. 13 ESPAR MODEL V7S AIR SOLENOID VALVE AND WIRING HARNESS						
1	XDFFF	D8435	CA 50 14451		WIRING HARNESS	1
					UOC:HE6	
2	PAFZZ	06090	222D163-4		.CABLE NIPPLE,ELECTR	2
					UOC:HE6	
3	PAFZZ	D8435	206 31 002		.CONNECTOR BODY,PLUG	1
					UOC:HE6	
4	PAFZZ	D8435	206 31 013		.CONNECTOR BODY,RECE	1
					UOC:HE6	
5	PAFZZ	DD779	180923		.CONNECTOR BODY,RECE	1
					UOC:HE6	
6	XDFZZ	04618	480115-1		.TERMINAL,QUICK DISC	1
					UOC:HE6	
7	PAFZZ	00779	480003-5		.CONNECTOR BODY,PLUG	1
					UOC:HE6	
8	PAFZZ	D8512	1-63007-0		.CONNECTOR BODY,PLUG	1
					UOC:HE6	
9	PAFZZ	14933	L00695		.SEMICONDUCTOR DEVIC	1
					UOCHE6	
10	PAFZZ	D8435	206 31 301		.CONNECTOR BODY,PLUG	1
					UOC:HE6	
11	PAFZZ	D8435	132 75 071		.CABLE NIPPLE,ELECTR	2
					UOC:HE6	
12	PAFZZ	D8435	20631304		.PLUG	1
					UOC:HE6	
13	PAFZZ	D8435	25 1244 05 02 00		VALVE,SOLENDID	1
					UOC:HE6	
14	PAFZZ	96906	MS35842-11		CLAMP,HOSE	1
					UOC:HE6	
15	PAFZZ	96906	MS21083N04		NUT,SELF-LOCKING,HE	9
					UOC:HE6	
16	PAFZZ	88044	AN960-10L		WASHER,FLAT	1
					UOC:HE4	

END OF FIGURE

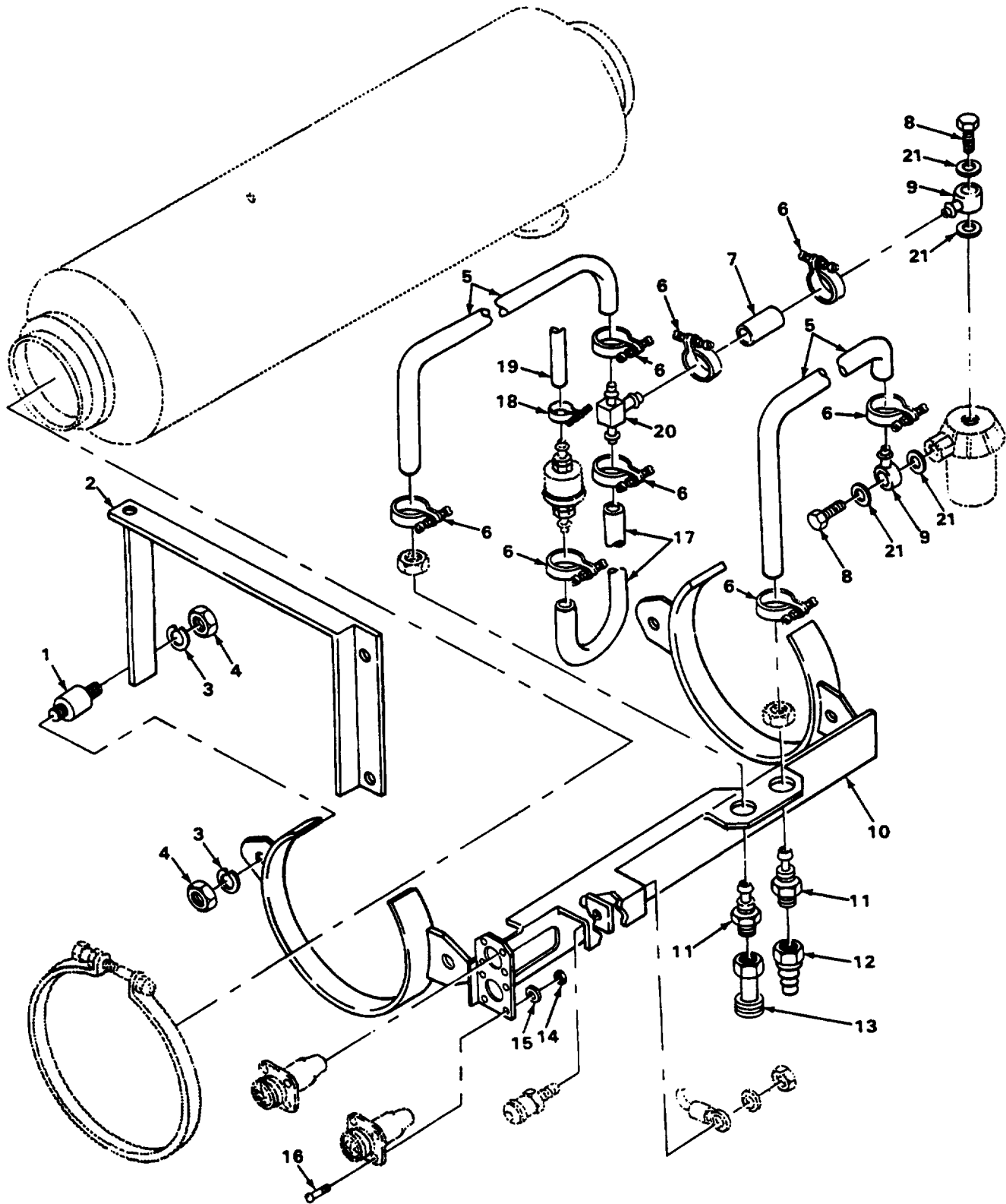

FIGURE 14. ESPAR MODEL V7S MOUNTING ASSEMBLY.

SECTION 11			TM9-2540-205-24&P			
(1)	(2)	(3)	(4)		(5)	(6)
ITEM NO	SMR CODE	CAGEC	PART NUMBER		DESCRIPTION AND USABLE ON CODES (UOC)	QTY
GROUP 2202 ACCESSORY ITEMS						
FIG. 14 ESPAR MODEL V7S MOUNTING ASSEMBLY						
1	PAFZZ	19207	12293275-3		MOUNT,RESILIENT UOC:HE6	4
2	PAFZZ	19207	12300354		BRACKET,MOUNTING UOC:HE6	2
3	PAFZZ	96906	MS35333-41		WASHER,LOCK UOC:HE6	8
4	PAFZZ	96906	MS35649-2312		NUT,PLAIN,HEXAGON UOC:HE6	8
5	MFFZZ	19207	12300346-1		HOSE MAKE FROM HOSE, P/N 483666 UOC:HE6	2
6	PAFZZ	D8435	10 2063 01 20 90		CLAMP,HOSE UOC:HE6	8
7	MFFZZ	19207	12300346-2		HOSE MAKE FROM HOSE, P/N 483666 UOC:HE6	1
8	PAFZZ	D8435	104-10-008		BOLT,FLUID PASSAGE UOC:HE6	2
9	PAFZZ	D8435	25 1352 88 0005		CONNECTION,MULITIPLE UOC:HE6	2
10	PAFZZ	19207	12329199		BRACKET,HOUSING UOC:HE6	1
11	PAFZZ	19207	12300470		ADAPTER,STRAIGHT,PI UOC:HEb	2
12	PAFZZ	19207	12300453-2		COUPLING HALF,QUICK	1
13	PAFZZ	19207	12300453-1		COUPLING BODY,TUBE UOC:HE6	1
14	PAFZZ	96906	MS21083N04		NUT,SELF-LOCKING,HE UOC:HE6	8
15	PAFZZ	96936	MS27183-4		WASHER,FLAT UOC:HE6	8
16	PAFZZ	96906	MS35190-226		SCREW,MACHINE UOC:HE6	8
17	MFFZZ	19207	12300346-3		HOSE MAKE FROM HOSE, PIN 483666 UOC:HE6	1
18	PAFZZ	19207	12300480		CLAMP UOC:HE6	2
19	XDFZZ	D8435	360 75 110		HOSE,NONMETALLIC UOC:HE6	1
20	PAFZZ	96906	MS24521-1		TEE,HOSE UOC:HE6	1
21	PAFZZ	D2081	50000900		GASKET UOC:HE6	4

END OF FIGURE

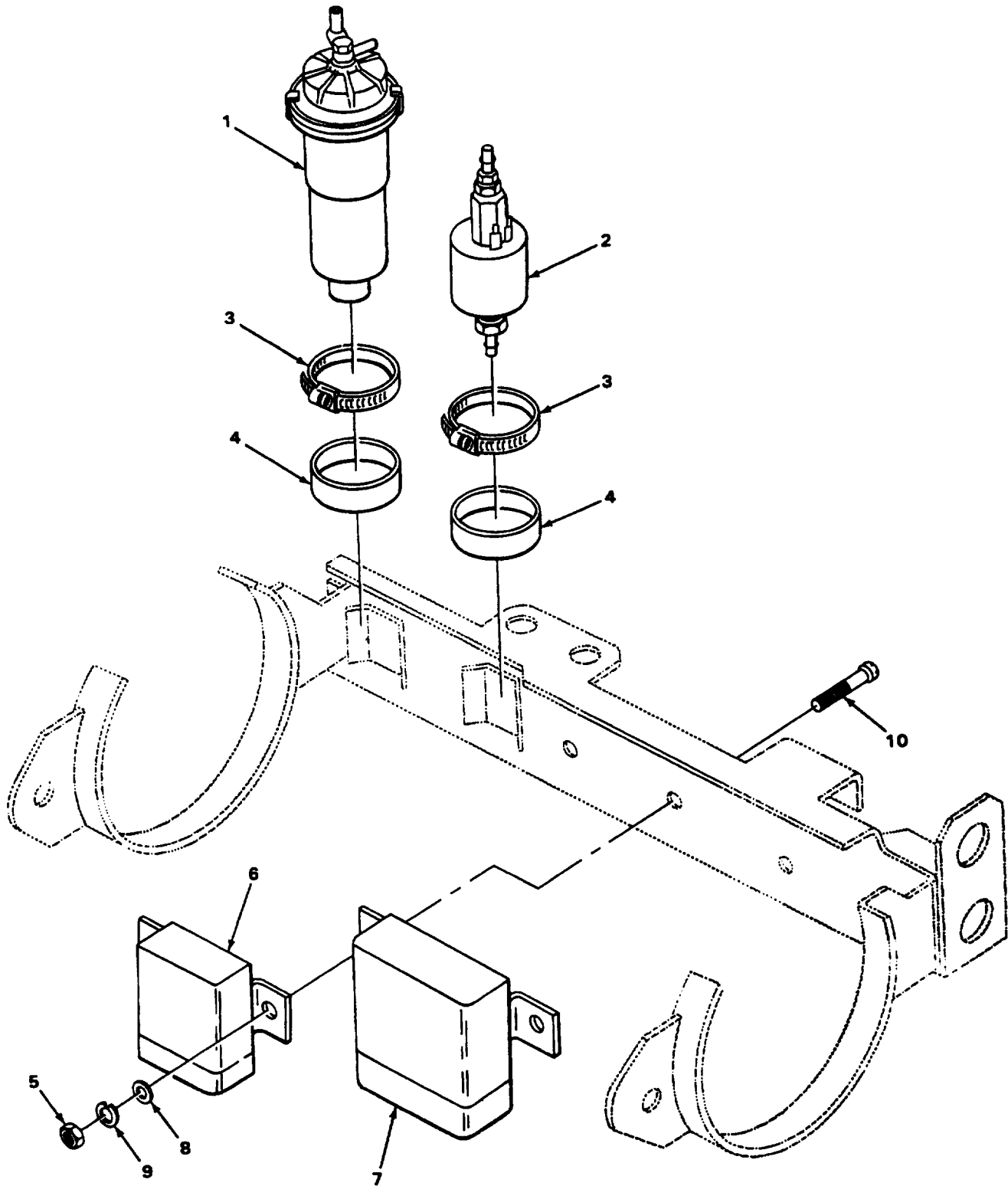

FIGURE 15. ESPAR MODEL V7S METER PUMP AND FUEL PUMP.

SECTION II			TM9-2540-205-24&P			
(1)	(2)	(3)	(4)		(5)	(6)
ITEM	SMR		PART			
NO	CODE	CAGEC	NUMBER		DESCRIPTION AND USABLE ON CODES (UQC)	QTY
GROUP 2202 ACCESSORY ITEMS						
FIG. 15 ESPAR MODEL V7S METER PUMP AND FUEL PUMP						
1	PAFZZ	D8435	25 1426 45 00 00		PUMP FUEL	1
					UOC:HE6	
2	PAFZZ	D8435	25 1452 45 00 00		DRIVE,TIP	1
					UOC:HE6	
3	PAFZZ	96906	MS35842-12		CLAMP,HOSE	1
					UOC:HE6	
4	MFFZZ	19207	201449001001-1		CUSHION MAKE FROM CUSHION, F/N 20	2
					1449 00 10 01	
					UOC:HE6	
5	PAFZZ	96906	MS35650-3252		NUT,PLAIN,HEXIGON	3
					UOC:HE6	
6	PAFZZ	D8435	20 1550 51 00 00		HEAT REGULATOR	1
					UOC:HE6	
7	PAFZZ	D8435	25 1244 53 00 00		IMPULES SWITCH	1
					UOC:HE6	
8	PAFZZ	96906	MS27183-10		WASHER,FLAT	3
					UOC:HE6	
9	PAFZZ	96906	MS122032		WASHER,LOCK	3
					UOC:HE6	
10	PAFZZ	96906	MS510RS-304		SCREW,CAP,HEXAGON	3
					UOC:HE6	

END OF FIGURE

SECTION II

TM9-2540-205-24&P

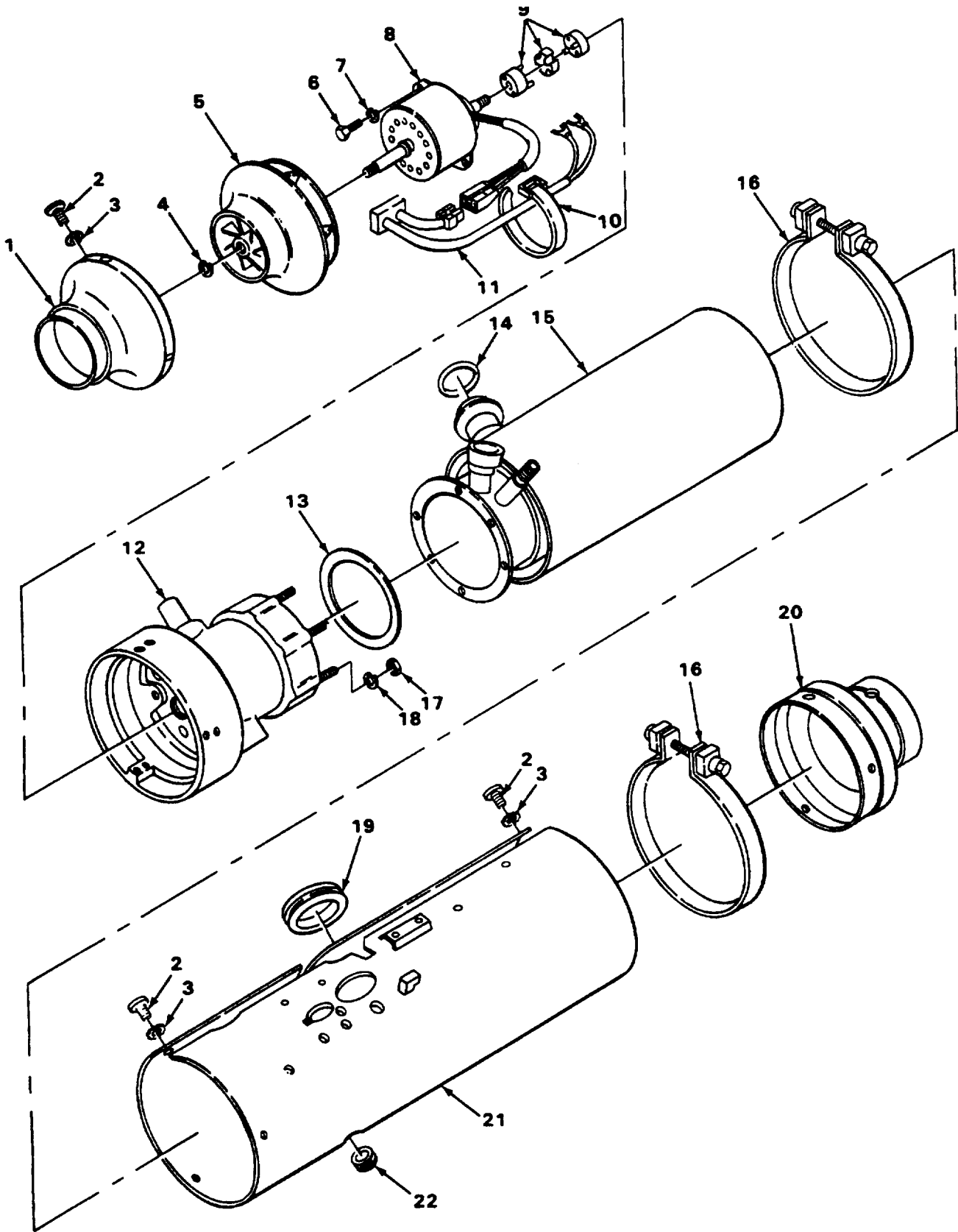

FIGURE 16. ESPAR MODEL V7S BURNER ASSEMBLY AND HEAT EXCHANGER.

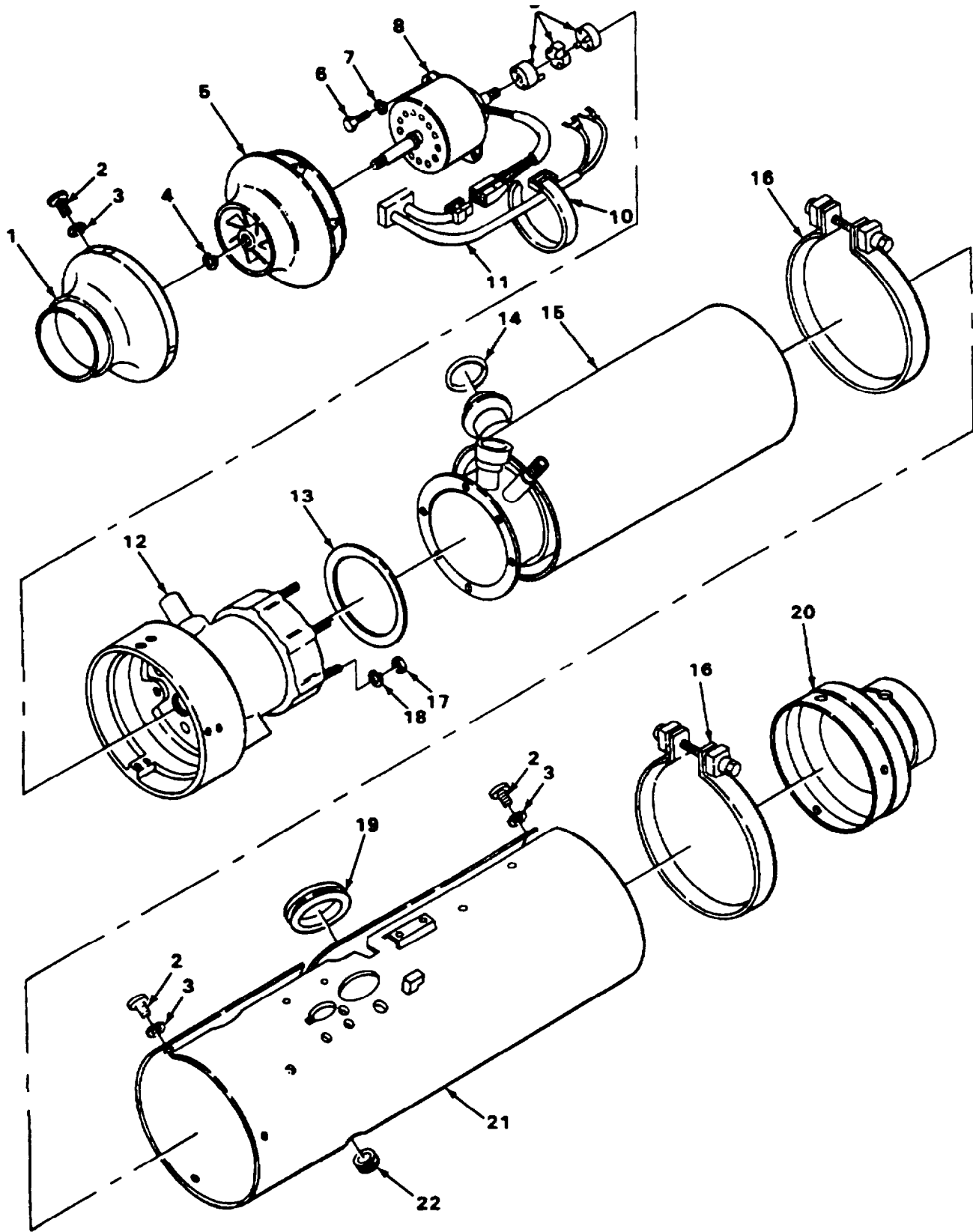

FIGURE 16. ESPAR MODEL V7S BURNER ASSEMBLY AND HEAT EXCHANGER.

SECTION II			TM9-2540-205-24&P			
(1)	(2)	(3)	(4)	(5)	(6)	
ITEM NO	SMR CODE	CAGEC	PART NUMBER	DESCRIPTION AND USABLE ON CODES(UOC)	QTY	
				GROUP 94 REPAIR KITS		
				GROUP 9401 PEPAIR KITS		
				FIG. KIT REPAIR KITS		
PAFZZ	78385	G704528		PARTS KIT,VEHICULAR PERSONNEL HEATER ASSEMBLY,BURNER,REPLACEMENT..	1	
				UOC:HE2,HE8		
				BURNER ASSEMBLY,SPA	(1) 11-1	
				CUP AND LEG ASSY	(1) 11-13	
				NUT,SELF-LOCKING,EX	(3) 11-2	
				PLATE AND BUSHING A	(1) 11-3	
				SCREW	(3) 11-14	
				SCREW,MACHINE	(1) 11-12	
				SHIELD,FUEL VAPORIZ	(1) 11-11	
				VAPGRIZER,FUEL	(1) 11-8	
				WASHER	(2) 11-6	
				WASHER	(2) 11-5	
				WASHER	(1) 11-10	
				WASHER	(1) 11-9	
				WASHER,SHOULDERED	(1) 11-7	
				WICK	(1) 11-4	
PAFZZ	78385	G705954		PARTS KIT,VALVE.....	1	
				UOC:HE2,HE8,H10		
				CORE,VALVE	(1) 8-14	
				DIAPHRAM ASSEMBLY	(1) 8-15	
				GASKET	(1) 8-26	
				PACKING,PREFCRMED	(1) 8-22	
				PACKING,PREFORMED	(1) 8-21	
				PACKING,PREFORMED	(1) 8-39	
				SCREEN,INLET	(1) 8-40	
				SEAL,PLAIN	(1) 8-41	
PAOZZ	19207	10947055		PARTS KIT,SWITCH.....	1	
				UOC:HE1,HE5,HE7		
				ROD	(1) 1-11	
				ROD QUARTZ	(1) 1-12	

END OF FIGURE

SECTION II

TM9-2540-205-24&P

(1) ITEM NO	(2) SMR CODE	(3) CAGEC	(4) PART NUMBER	(5) DESCRIPTION AND USABLE ON CODES(UOC)	(6) QTY
-------------------	--------------------	--------------	-----------------------	---	------------

GROUP 95 GENERAL USE STANDARDIZED PARTS

GROUP 9501 BULK MATERIEL

FIG. BULK

1	PAFZZ	02280	483666	HOSE, NONMETALLIC.....	V
				UOC:HE6	
2	PAFZZ	D8435	20 1449 00 10 01	CUSHICN.....	V
				UOC:HE6	

END OF FIGURE

CROSS-REFERENCE INDEXES

NATIONAL STOCK NUMBER INDEX					
STOCK NUMBER	FIG.	ITEM	STOCK NUMBER	FIG.	ITEM
5961-00-023-3900	13	9	4730-00-460-6725	1	3
5975-00-025-7947	13	2	5930-00-475-5537	1	1
5310-00-043-0520	15	5	5935-00-481-2012	13	7
5945-00-055-2813	2	8	5340-00-482-5920	4	1
5325-00-057-7048	4	4	2540-00-482-5922	4	3
5325-00-059-5767	4	14	5935-00-498-8653	1	6
5310-00-061-0004	7	3	6105-00-557-2591	5	3
4730-00-063-7919	1	10	4520-00-567-1886	1	4
5305-00-088-6284	1	7	5310-00-596-7691	2	6
5305-00-115-9406	9	9	5310-00-606-8281	7	26
5305-00-115-9934	8	19	2540-00-608-8102	9	3
5330-00-127-5327	4	18	2540-00-706-5159	9	15
2540-00-127-5337	4	8	4140-00-763-1228	9	17
5330-00-133-6985	4	12	5310-00-765-3197	10	11
5310-00-138-4315	8	5	5360-00-790-6071	8	16
5330-00-138-4440	8	39	5310-00-809-4058	15	8
5305-00-145-0828	8	32	4140-00-812-5016	6	11
5310-00-159-6209	15	9	4810-00-818-4451	3	3
5310-00-167-0721	14	3	5310-00-823-8804	10	29
5310-00-176-0834	13	16	5325-00-827-2057	7	18
5305-00-181-0877	7	7		10	18
	10	26	5310-00-829-9981	14	4
4730-00-186-7797	3	8	5325-00-866-3650	4	2
2540-00-216-5722	7	17	5310-00-878-7196	11	2
4520-00-217-5782	7	21	5305-00-888-5859	2	1
5305-00-226-7222	10	1		4	9
6105-00-234-1278	9	11	2540-00-893-5458	2	5
5305-00-249-5278	1	5	5310-00-903-2710	2	10
	6	16	4730-00-908-3193	15	3
2540-00-255-0775	KIT		4730-00-908-3194	13	14
4730-00-278-0187	8	13	4720-00-913-5910	BULK	1
5930-00-283-6562	7	15	5305-00-914-6125	15	10
5310-00-285-5112	8	29	2590-00-925-8050	KIT	
5330-00-285-5114	8	26	5310-00-925-9645	13	15
4730-00-288-9928	3	9		14	14
4730-00-319-0454	3	10	5310-00-934-9757	9	16
5360-00-327-5879	8	25		10	12
5310-00-333-7341	7	2	5310-00-934-9762	8	2
5305-00-401-0831	6	22	2590-00-941-8678	5	9
5905-00-402-7698	5	6	2590-00-941-8680	3	6
5305-00-443-7997	1	8	5310-00-950-1310	14	15
5305-00-443-7998	2	2	5305-00-958-5457	14	16
6680-00-443-9839	4	5	4540-00-968-7782	3	2
5310-00-455-4938	5	7	5930-00-968-7784	4	19
	6	13	5945-00-968-7785	2	11
	6	24	4810-00-968-7786	3	1
2940-00-456-1573	8	17	5940-00-983-6082	7	9
4540-00-456-1575	5	10	5305-00-984-4983	7	16
5310-00-456-2635	2	7	5305-00-984-6191	7	12
	4	17		9	2

CROSS-REFERENCE INDEXES

NATIONAL STOCK NUMBER INDEX					
STOCK NUMBER	FIG.	ITEM	STOCK NUMBER	FIG.	ITEM
2540-00-994-0983	4	13	4730-01-116-3691	14	20
5330-01-008-6523	8	41	5310-01-126-0466	11	5
5330-01-008-6527	8	21	5310-01-126-0467	11	9
5340-01-027-1241	6	15	5325-01-129-0277	7	19
5310-01-027-1353	3	4	2540-01-133-5293	3	7
5305-01-030-7344	2	4	5325-01-134-3825	10	38
5961-01-037-0687	9	7	5325-01-134-3826	10	3
5340-01-037-7049	5	8	4730-01-134-8294	14	11
	6	25	2540-01-136-0981	6	26
5340-01-047-6031	10	9	2540-01-136-8703	10	2
5940-01-054-0278	7	4	2540-01-136-8705	10	35
6150-01-054-0296	9	8	5340-01-136-8707	10	30
6150-01-054-0297	8	11	2540-01-136-8713	10	6
4710-01-054-0313	9	19	2590-01-136-8714	10	25
	10	34	2540-01-136-8715	10	20
5330-01-054-9752	7	7	6150-01-136-8730	10	22
2540-01-057-5714	11	3	5305-01-136-8734	11	12
4820-01-057-5927	8	42	5307-01-136-8740	8	35
2540-01-057-7443	11	11	5310-01-137-6801	10	16
5305-01-057-9322	8	33	5970-01-142-3179	8	8
6150-01-058-3465	7	25	5935-01-143-4665	13	5
6150-01-058-3466	7	24	5305-01-146-1664	8	10
5940-01-058-6470	7	8	4730-01-151-2740	14	12
5306-01-059-0188	7	13	5340-01-151-2742	14	1
	10	10	4730-01-151-2754	14	13
5310-01-059-0988	11	7	6105-01-158-3198	6	12
5999-01-059-6609	7	23	2540-01-162-3640	8	31
5305-01-066-3431	10	33	2540-01-162-3641	10	13
	11	14	5330-01-162-3745	10	15
5975-01-067-3359	7	22	4730-01-162-3833	10	39
	10	24	5330-01-162-7031	10	27
9390-01-070-5959	11	4	4730-01-164-5807	6	8
5905-01-075-2798	6	17	2540-01-164-5893	1	2
6110-01-075-2799	10	23	2540-01-166-6374	4	12
5975-01-077-2222	9	6	2540-01-167-4294	4	13
4710-01-077-7720	7	10	2540-01-167-7248	4	15
2540-01-077-7723	9	18	6110-01-167-7252	2	11
2540-01-077-7724	9	4	2540-01-167-8058	6	10
5930-01-077-7793	7	14	4730-01-168-4255	10	36
	8	12	2540-01-169-5137	8	27
2540-01-079-4637	7	11	4810-01-171-4643	KIT	
6110-01-097-3342	9	14	4810-01-171-4644	8	1
5305-01-097-8180	7	10	6105-01-171-4722	10	17
	10	5	5305-01-173-0948	4	9
5340-01-098-6048	7	1		6	2
5340-01-109-5671	10	32	4720-01-175-0513	10	37
5330-01-109-5945	10	31	5305-01-176-7670	4	6
5330-01-109-5947	10	7	4540-01-210-2693	8	38
2540-01-114-7458	14	2	5340-01-222-7986	14	10
2540-01-115-1805	4	15	2540-01-227-5993	6	21

CROSS-REFERENCE INDEXES

NATIONAL STOCK NUMBER INDEX					
STOCK NUMBER	FIG.	ITEM	STOCK NUMBER	FIG.	ITEM
5895-01-230-0266	8	36	5935-12-171-8131	13	12
2540-01-234-4874	7	5	5935-12-171-8132	13	3
5310-01-234-9416	8	3	5975-12-171-8479	13	11
2590-01-238-2770	6	1	5935-12-171-9976	12	10
4730-01-269-1233	14	18	3010-12-172-3646	16	9
5330-01-269-7454	6	28	6105-12-172-4011	16	8
6105-01-269-8467	9	11	2540-12-190-9540	15	2
5961-01-270-9631	9	7	4730-12-196-3832	14	9
6110-01-276-2053	10	23	5935-12-198-9039	13	8
5310-12-126-3830	16	17			
4730-12-136-1127	14	6			
4730-12-140-3653	12	8			
5310-12-142-0656	16	3			
5310-12-142-0657	12	4			
	16	18			
5310-12-142-0659	16	7			
5305-12-142-5547	12	3			
5305-12-142-5659	12	12			
5365-12-153-6444	16	4			
5330-12-156-5014	14	21			
5330-12-157-7529	16	19			
4730-12-162-0513	14	8			
6685-12-167-1067	12	7			
4810-12-167-1474	13	13			
5930-12-167-3195	12	9			
5930-12-167-3196	12	17			
5905-12-167-3198	12	6			
2540-12-167-3599	12	15			
5999-12-167-3600	12	5			
2540-12-167-3601	15	1			
2920-12-171-1836	12	16			
4530-12-171-2045	16	12			
5310-12-171-2242	12	1			
5330-12-171-2725	16	13			
5940-12-171-2844	12	11			
5340-12-171-2845	16	16			
2540-12-171-3201	12	2			
2540-12-171-3207	15	7			
2540-12-171-3208	15	6			
2540-12-171-3408	16	1			
2540-12-171-3410	16	20			
5910-12-171-5192	12	14			
5325-12-171-5193	16	22			
5935-12-171-5488	13	4			
5935-12-171-5507	13	10			
5330-12-171-6331	16	14			
4140-12-171-6366	16	5			
5325-12-171-6731	12	13			
5915-12-171-6732	16	11			
5975-12-171-8130	16	10			

CROSS-REFERENCE INDEXES

CAGEC	PART NUMBER	PART NUMBER INDEX		FIG.	ITEM
			STOCK NUMBER		
88044	AN911-1		4730-00-186-7797	3	8
88044	AN960-10L		5310-00-167-0834	13	16
46522	A14141		4730-00-319-0454	3	10
46522	A18167G2		4520-00-567-1886	1	4
46522	A50177G1			1	11
46522	A50178G1			1	12
46522	A50779G1			6	18
46522	A50805G2-3		5340-00-482-5920	4	1
46522	A52342G1		5330-00-127-5327	4	18
46522	A52364G1		5325-00-059-5767	4	14
46522	A52819G1		5330-00-133-6985	4	12
46522	A55106-G1			6	27
46522	A55302		2540-01-167-7248	4	15
46522	A55313-G1			6	6
46522	A55314-G1		5330-01-269-7454	6	28
46522	A55455-G1			2	13
07639	A7471-4		5305-00-088-6284	1	7
05657	A8		4730-00-063-7919	1	10
46522	B14658G1-1		4140-00-812-5016	6	11
D8286	B4DIN127A3P		5310-12-142-0656	16	3
46522	B50035G4		2540-00-482-5922	4	3
46522	B50074-G11-6			2	3
46522	B50553-G11-5			4	16
46522	B52809G1		5935-00-498-8653	1	6
46522	B52843G2		2540-00-893-5458	2	5
46522	B52845G1		6680-00-443-9839	4	5
46522	B54302G1		2540-01-133-5293	3	7
46522	B54818-G1-1			6	23
46522	B54845G1		5905-01-075-2798	6	17
46522	B54859-G1-1			6	20
46522	B54859-G2-1			6	5
46522	B54869-G1-1			6	3
46522	B54870-G1			6	4
46522	B54936-G1-1		4730-01-164-5807	6	8
46522	B55075-G1		2540-01-166-6374	4	12
46522	B55101-G1		2540-01-167-4294	4	13
46522	B55304		6110-01-167-7252	2	11
D8435	CA 50 14451			13	1
78385	CONL			9	5
16236	CS-4520-SV-0705		4520-00-217-5782	7	21
46522	C16971G2		6105-00-557-2591	5	3
46522	C17686-G2-2			6	14
46522	C52830-G3-1			4	11
46522	C52831-G2			5	2
46522	C52833-G1-1			4	7
46522	C52836-G1-1			5	1
46522	C52838G1-1		2540-00-127-5337	4	8
46522	C52847G1		4810-00-968-7786	3	1
46522	C52848G1		4810-00-818-4451	3	3
46522	C54508-G1-1			2	9
46522	C54804-G1-1		2540-01-227-5993	6	21

CROSS-REFERENCE INDEXES

CAGEC	PART NUMBER	PART NUMBER INDEX		FIG.	ITEM
			STOCK NUMBER		
46522	C54807-G1-1			6	9
46522	C54821-G1-1			4	11
46522	C54823-G1-1			4	7
46522	C54868-G1-1			6	7
46522	C54922-G1		2540-01-167-8058	6	10
46522	C54932-G1-1		2540-01-164-5893	1	2
D8773	DIN72571-1X7-ST- VERZINKT			12	18
46522	D52812-G1-1			4	10
46522	D54805-G1-1			4	10
57733	G489276		4140-00-763-1228	9	17
78385	G700749		2540-00-706-5159	9	15
78385	G702562-27		6150-01-054-0297	8	11
78385	G704288-2		4710-01-077-7720	7	20
78385	G704526		5930-00-283-6562	7	15
78385	G704528		2540-00-255-0775	KIT	
78385	G704557		6105-00-234-1278	9	11
78385	G704612			9	20
78385	G704625		5340-01-098-6048	7	1
78385	G704656		2540-01-077-7723	9	18
78385	G704682		6150-01-058-3465	7	25
78385	G704683		6150-01-058-3466	7	24
78385	G704974			9	10
78385	G705030		2540-01-234-4874	7	5
78385	G705065		5340-01-109-5671	10	32
78385	G705080		2540-01-057-5714	11	3
78385	G705081			11	1
78385	G705102		2540-01-077-7724	9	4
78385	G705209			11	13
78385	G705225			9	1
78385	G705230			9	12
78385	G705241		5961-01-037-0687	9	7
78385	G705292			10	19
78385	G705293			10	8
78385	G705294-1			10	4
78385	G705300		2540-01-136-8713	10	6
78385	G705315		2590-01-136-8714	10	25
78385	G705319-1		6105-01-171-4722	10	17
78385	G705320		6110-01-075-2799	10	23
78385	G705341		2540-01-136-8705	10	35
78385	G705353		2540-01-079-4637	7	11
78385	G705362		5940-01-058-6470	7	8
78385	G705368		2540-01-136-8715	10	20
78385	G705377		6150-01-136-8730	10	22
78385	G705558		2540-01-169-5137	8	27
78385	G7055989-44			8	30
78385	G705850			8	15
78385	G705903-5			8	7
78385	G705903-7			8	6
78385	G705954		4810-01-171-4643	KIT	
78385	G705990		4810-01-171-4644	8	1

CROSS-REFERENCE INDEXES

CAGEC	PART NUMBER	PART NUMBER INDEX		FIG.	ITEM
			STOCK NUMBER		
78385	G706144			9	1
57733	G706147			9	17
78385	G706149		6105-01-269-8467	9	11
78385	G706157		6110-01-276-2053	10	23
78385	G706159		5961-01-270-9631	9	7
78385	G706166			9	4
78385	G738396		2540-01-136-8703	10	2
79497	KA56BR101		5325-00-827-2057	7	18
14933	L00695		5961-00-023-3900	13	9
96906	MS122032		5310-00-159-6209	15	9
96906	MS21043-08		5310-00-878-7196	11	2
96906	MS21083N04		5310-00-925-9645	13	15
				14	14
96906	MS24521-1		4730-01-116-3691	14	20
96906	MS27183-10		5310-00-809-4058	15	8
96906	MS27183-4		5310-00-950-1310	14	15
96906	MS27183-41		5310-00-765-3197	10	11
96906	MS27183-9		5310-00-823-8804	10	29
96906	MS35190-226		5305-00-958-5457	14	16
96906	MS35206-226		5305-00-984-4983	7	16
96906	MS35206-243		5305-00-984-6191	7	12
				9	2
96906	MS35273-44		5305-00-226-7222	10	1
96906	MS35333-41		5310-00-167-0721	14	3
96906	MS35335-32		5310-00-596-7691	2	6
96906	MS35649-2312		5310-00-829-9981	14	4
96906	MS35649-282		5310-00-934-9757	9	16
				10	12
96906	MS35649-286		5310-00-934-9762	8	2
96906	MS35650-3252		5310-00-043-0520	15	5
96906	MS35842-11		4730-00-908-3194	13	14
96906	MS35842-12		4730-00-908-3193	15	3
96906	MS39171-12		4730-00-278-0187	8	13
96906	MS45904-57		5310-00-061-0004	7	3
96906	MS51095-304		5305-00-914-6125	15	10
96906	MS51412-2		5310-01-234-9416	8	3
96906	MS51849-53		5305-00-115-9406	9	9
96906	MS51849-55		5305-00-115-9934	8	19
96906	MS51859-5		5310-00-138-4315	8	5
96906	MS9068-115		5330-00-138-4440	8	39
46522	M25000-5		5325-00-057-7048	4	4
46522	M30002-43		5340-01-027-1241	6	15
46522	M37001-45			5	4
D8773	S10/9ZY		4730-12-140-3653	12	8
D8046	007985005127		5305-12-142-5547	12	3
59556	015-00003-28			1	9
6N299	0920416		4730-00-460-6725	1	3
D8512	1-63007-0		5935-12-198-9039	13	8
D8435	10 2062 19 22 09		5340-12-171-2845	16	16
D8435	10 2063 01 20 90		4730-12-136-1127	14	6
D8435	103 10 063			16	6

CROSS-REFERENCE INDEXES

CAGEC	PART NUMBER	PART NUMBER INDEX		FIG.	ITEM
			STOCK NUMBER		
D8435	103 10 307			16	2
D8435	104-10-008		4730-12-162-0513	14	8
D8435	108 10 323		5305-12-142-5659	12	12
19207	10947055		2590-00-925-8050	KIT	
D8435	110 10 025		5310-12-126-3830	16	17
19207	11640296		4540-00-456-1575	5	10
19207	11663062-1		9390-01-070-5959	11	4
19207	11669574		6110-01-097-3342	9	14
19207	12293275-3		5340-01-151-2742	14	1
19207	12300346-1			14	5
19207	12300346-2			14	7
19207	12300346-3			14	17
19207	12300356		2540-01-114-7458	14	2
19207	12300453-1		4730-01-151-2754	14	13
19207	12300453-2		4730-01-151-2740	14	12
19207	12300470		4730-01-134-8294	14	11
19207	12300480		4730-01-269-1233	14	18
19207	12329199		5340-01-222-7986	14	10
46522	1310-0832-06-17		5305-01-176-7670	4	6
D8435	132 75 071		5975-12-171-8479	13	11
57733	170123		5305-00-181-0877	7	6
				10	26
78385	170315			10	28
D8435	171 22 006		5365-12-153-6444	16	4
D8435	171 22 084		5310-12-142-0657	12	4
				16	18
D8435	171 22 086		5310-12-142-0659	16	7
00779	180923		5935-01-143-4665	13	5
81349	2N6286			2	12
D8435	20 1101 01 08 05		5325-12-171-6731	12	13
D8435	20 1280 09 01 03		5325-12-171-5193	16	22
D8435	20 1348 03 00 32		6685-12-167-1067	12	7
D8435	20 1449 00 10 01			BULK	2
D8435	20 1550 51 00 00		2540-12-171-3208	15	6
D8435	20 8542 11 00 02		5330-12-157-7529	16	19
46522	2010-0440-02-13			3	5
46522	2010-0832-08-13		5305-00-443-7997	1	8
D8435	20114426003		5310-12-171-2242	12	1
19207	201449001001-1			15	4
D8435	206 00 150		2920-12-171-1836	12	16
D8435	206 31 002		5935-12-171-8132	13	3
D8435	206 31 013		5935-12-171-5488	13	4
D8435	206 31 301		5935-12-171-5507	13	10
46522	2060-0632-04-41		5305-00-443-7998	2	2
D8435	20631304		5935-12-171-8131	13	12
D8435	209 31 070		5975-12-171-8130	16	10
46522	2210-0832-20-17		5305-00-401-0831	6	22
06090	222D163-4		5975-00-025-7947	13	2
46522	2251-0832-06-17		5305-00-249-5278	1	5
46522	2251-0832-06-17		5305-00-249-5278	1	5
				6	16
46522	2251-0832-08-17			6	19

CROSS-REFERENCE INDEXES

CAGEC	PART NUMBER	PART NUMBER INDEX		FIG.	ITEM
			STOCK NUMBER		
46522	2251-0832-20-17			5	5
46522	2251-1032-08-17		5305-01-030-7344	2	4
D8435	25 1214 15 09 00		5940-12-171-2844	12	11
D8435	25 1226 01 00 04		5330-12-171-2725	16	13
D8435	25 1244 01 00 02		2540-12-171-3408	16	1
D8435	25 1244 01 05 00		5905-12-167-3198	12	6
D8435	25 1244 01 06 00		5910-12-171-5192	12	14
D8435	25 1244 01 07 00		5930-12-167-3196	12	17
D8435	25 1244 01 08 00		2540-12-171-3410	16	20
D8435	25 1244 02 00 00			16	21
D8435	25 1244 05 02 00		4810-12-167-1474	13	13
D8435	25 1244 06 00			16	15
D8435	25 1244 15 01 00		4530-12-171-2045	16	12
D8435	25 1244 15 04 00		6105-12-172-4011	16	8
D8435	25 1244 15 05 00		5915-12-171-6732	16	11
D8435	25 1244 53 00 00		2540-12-171-3207	15	7
D8435	25 1244 89 01 01		5330-12-171-6331	16	14
D8435	25 1244 99 35 00		5930-12-167-3195	12	9
D8435	25 1352 88 0005		4730-12-196-3832	14	9
D8435	25 1426 15 02 00		4140-12-171-6366	16	5
D8435	25 1426 45 00 00		2540-12-167-3601	15	1
D8435	25 1426 45 00 00		2540-12-167-3601	15	1
D8435	25 1426 99 55 00		3010-12-172-3646	16	9
D8435	25 1431 01 00 03		2540-12-167-3599	12	15
D8435	25 1447 01 04 00		5999-12-167-3600	12	5
D8435	25 1452 45 00 00		2540-12-190-9540	15	2
D8435	251244010003		2540-12-171-3201	12	2
46522	2951-1032-0617		5305-01-173-0948	4	9
				6	2
46522	30002-83		5310-01-027-1353	3	4
11327	3004051		5305-00-888-5859	2	1
				4	9
92872	3191		5325-00-827-2057	10	18
D8435	360 75 110			14	19
81349	38TB4		5940-00-983-6082	7	9
46522	42-0632-13		5310-00-903-2710	2	10
46522	42-0832-17		5310-00-455-4938	5	7
				6	13
				6	24
46522	42-1032-17		5310-00-456-2635	2	7
				4	17
57733	474669		5330-00-285-5114	8	26
78385	474677		2940-00-456-1573	8	17
78385	476229		5310-00-285-5112	8	29
78385	476339		5360-00-327-5879	8	25
00779	48003-5		5935-00-481-2012	13	7
04618	480115-1			13	6
02280	483666		4720-00-913-5910	BULK	1
78385	487283		5310-00-333-7341	7	2
78385	488066		5305-01-097-8180	7	10
				10	5
78385	488756		5310-00-606-8281	7	26

CROSS-REFERENCE INDEXES

CAGEC	PART NUMBER	PART NUMBER INDEX		FIG.	ITEM
			STOCK NUMBER		
78385	488773		2540-00-608-8102	9	3
78385	489209		5360-00-790-6071	8	16
D2081	50000900		5330-12-156-5014	14	21
46522	50035G2		5325-00-866-3650	4	2
46522	52576G1		5930-00-968-7784	4	19
46522	52820-G2		2540-00-994-0983	4	13
46522	52828G1		2590-00-941-8678	5	9
46522	52850G1		4540-00-968-7782	3	2
46522	52876G1		2590-00-941-8680	3	6
46522	54178G2		5905-00-402-7698	5	6
46522	54180G1		5340-01-037-7049	5	8
				6	25
46522	54733G1		2540-01-115-1805	4	15
46522	55102-G2		2540-01-136-0981	6	26
46522	55310-G1		6105-01-158-3198	6	12
46522	55326-G1		2590-01-238-2770	6	1
30327	68F1-8		4730-00-288-9928	3	9
57733	700042			10	14
78385	700380		5999-01-059-6609	7	23
78385	701226-24		6150-01-054-0296	9	8
78385	701761		5305-00-145-0828	8	32
78385	703129		5975-01-067-3359	7	22
			5975-01-077-2222	9	6
			5975-01-067-3359	10	24
78385	704190		5310-01-137-6801	10	16
				11	10
78385	704225		2540-00-216-5722	7	17
78385	704401		5930-01-077-7793	7	14
				8	12
78385	704406		5330-01-008-6527	8	21
78385	704431-3			8	34
78385	704435		5305-01-057-9322	8	33
78385	704436		5305-01-146-1664	8	10
78385	704447-1			8	9
78385	704555		5306-01-059-0188	7	13
				10	10
78385	704579		4820-01-057-5925	8	42
78385	704623		2540-01-057-7443	11	11
78385	704635		4710-01-054-0313	9	19
				10	34
78385	704667		5330-01-054-9752	7	7
78385	704883			8	22
78385	704980		5330-01-109-5947	10	7
78385	705032		5305-01-066-3431	10	33
				11	14
78385	705078		5310-01-126-0466	11	5
78385	705078		5310-01-126-0466	11	5
78385	705079			11	8
78385	705116		5310-01-126-0467	11	9
78385	705117		5305-01-136-8734	11	12
78385	705135		5310-01-059-0988	11	7
78385	705136			11	6

CROSS-REFERENCE INDEXES

CAGEC	PART NUMBER	PART NUMBER INDEX		FIG.	ITEM
			STOCK NUMBER		
78385	705236			9	13
78385	705340		5340-01-136-8707	10	30
78385	705345		5307-01-136-8740	8	35
78385	705356		5325-01-129-0277	7	19
78385	705556			8	28
78385	705557-1		2540-01-162-3640	8	31
78385	705640-1		4730-01-168-4255	10	36
78385	705640-2		4730-01-162-3833	10	39
78385	705691		5330-01-162-7031	10	27
78385	705692		5330-01-162-3745	10	15
78385	705836			8	18
78385	705838			8	43
78385	705840		5895-01-230-0266	8	36
78385	705841			8	23
78385	705842			8	40
78385	705843		4540-01-210-2693	8	38
78385	705845			8	24
78305	705847			8	37
78385	705931			8	4
78385	719676			10	21
78385	720942			8	14
78385	722058		5340-01-047-6031	10	9
78385	730050-2		5330-01-109-5945	10	31
78385	735411		5330-01-008-6523	8	41
78385	735447-5		5970-01-142-3179	8	8
78385	735762		5940-01-054-0278	7	4
78385	736641		5325-01-134-3825	10	38
78385	738448		5325-01-134-3826	10	3
78385	738457		4720-01-175-0513	10	37
78385	738460-2		2540-01-162-3641	10	13
78385	7705846			8	20
19207	8376101		5930-00-475-5537	1	1
19207	8737699		5945-00-968-7785	2	11
19207	8737832		5945-00-055-2813	2	8
D8512	925075		5935-12-171-9976	12	10

CROSS-REFERENCE INDEXES

FIG.	ITEM	FIGURE AND ITEM NUMBER INDEX STOCK NUMBER	CAGEC	PART NUMBER
BULK	1	4720-00-913-5910	02280	483666
BULK	2		D8435	20 1449 00 10 01
KIT		2540-00-255-0775	78385	G704528
KIT		2590-00-925-8050	19207	10947055
KIT		4810-01-171-4643	78385	G705954
1	1	5930-00-475-5537	19207	8376101
1	2	2540-01-164-5893	46522	C54932-G1-1
1	3	4730-00-460-6725	6N299	0920416
1	4	4520-00-567-1886	46522	A18167G2
1	5	5305-00-249-5278	45622	2251-0832-06-17
1	6	5935-00-498-8653	46522	B52809G1
1	7	5305-00-088-6284	07639	A7471-4
1	8	5305-00-443-7997	46522	2010-0832-08-13
1	9		59556	015-00003-28
1	10	4730-00-063-7919	05657	A8
1	11		46522	A50177G1
1	12		46522	A50178G1
2	1	5305-00-888-5859	11327	3004051
2	2	5305-00-443-7998	46522	2060-0632-04-41
2	3		46522	B50074-G11-6
2	4	5305-01-030-7344	46522	2251-1032-08-17
2	5	2540-00-893-5458	46522	B52843G2
2	6	5310-00-596-7691	96906	MS35335-32
2	7	5310-00-456-2635	46522	42-1032-17
2	8	5945-00-055-2813	19207	8737832
2	9		46522	C54508-G1-1
2	10	5310-00-903-2710	46522	42-0632-13
2	11	5945-00-968-7785	19207	8737699
2	11	6110-01-167-7252	46522	855304
2	12		81349	2N6286
2	13		46522	A55455-G1
3	1	4810-00-968-7786	46522	052847G1
3	2	4540-00-968-7782	46522	52850G1
3	3	4810-00-818-4451	46522	C52848G1
3	4	5310-01-027-1353	46522	30002-83
3	5		46522	2010-0440-02-13
3	6	2590-00-941-8680	46522	52876G1
3	7	2540-01-133-5293	46522	B54302G1
3	8	4730-00-186-7797	88044	AN911-1
3	9	4730-00-288-9928	30327	68F1-8
3	10	4730-00-319-0454	46522	A14141
4	1	5340-00-482-5920	46522	A50805G2-3
4	2	5325-00-866-3650	46522	50035G2
4	3	2540-00-482-5922	46522	B50035G4
4	4	5325-00-057-7048	46522	M25000-5
4	5	6680-00-443-9839	46522	B52845G1
4	6	5305-01-176-7670	46522	1310-0832-06-17
4	7		46522	C52833-G1-1
4	7		46522	C54823-G1-1
4	8	2540-00-127-5337	46522	C52838G1-1
4	9	5303-00-888-5859	11327	3004051

CROSS-REFERENCE INDEXES

FIG.	ITEM	FIGURE AND ITEM NUMBER INDEX STOCK NUMBER	CAGEC	PART NUMBER
4	9	5305-01-173-0948	46522	2951-1032-06-17
4	10		46522	D52812-G1-1
4	10		46522	D54805-G1-1
4	11		46522	C52830-G3-1
4	11		46522	C54821-G1-1
4	12	2540-01-166-6374	46522	B55075-G1
4	12	5330-00-133-6985	46522	A52819G1
4	13	2540-00-994-0983	46522	52820-G2
4	13	2540-01-167-4294	46522	B55101-G1
4	14	5325-00-059-5767	46522	A52364G1
4	15	2540-01-115-1805	46522	54733G1
4	15	2540-01-167-7248	46522	A55302
4	16		46522	B50553-G11-5
4	17	5310-00-456-2635	46522	42-1032-17
4	18	5330-00-127-5327	46522	A52342G1
4	19	5930-00-968-7784	46522	52576G1
5	1		46522	C52836-G1-1
5	2		46522	C52831-G2
5	3	6105-00-557-2591	46522	016971G2
5	4		46522	M37001-45
5	5		46522	2251-0832-20-17
5	6	5905-00-402-7698	46522	54178G2
5	7	5310-00-455-4938	46522	42-0832-17
5	8	5340-01-037-7-49	46522	54180G1
5	9	2590-00-941-8678	46522	52828G1
5	10	4540-00-456-1575	19207	11640296
6	1	2590-01-238-2770	46522	55326-G1
6	2	5305-01-173-0948	46522	2951-1032-06-17
6	3	5305-01-173-0948	46522	B54869-G1-1
6	4		46522	B54870-G1
6	5		46522	B54859-G2-1
6	6		46522	A55313-G1
6	7		46522	C54868-G1-1
6	8	4730-01-164-5807	46522	B54936-G1-1
6	9		46522	C54807-G1-1
6	10	2540-01-167-8058	46522	C54922-G1
6	11	4140-00-812-5016	46522	B14658G1-1
6	12	6105-01-158-3198	46522	55310-G1
6	13	5310-00-455-4938	46522	42-0832-17
6	14		46522	C17686-G2-2
6	15	5340-01-027-1241	46522	M30002-43
6	16	5305-00-249-5278	46522	2251-0832-06-17
6	17	5905-01-075-2798	46522	B54845G1
6	18		46522	A50779G1
6	19		46522	2251-0832-08-17
6	20		46522	B54859-G1-1
6	21	2540-01-227-5993	46522	C54804-G1-1
6	22	5305-00-401-0831	46522	2210-0832-20-17
6	23		46522	B54818-G1-1
6	24	5310-00-455-4938	46522	42-0832-17
6	25	5340-01-037-7049	46522	54180G1

CROSS-REFERENCE INDEXES

FIG.	ITEM	FIGURE AND ITEM NUMBER INDEX STOCK NUMBER	CAGEC	PART NUMBER
6	26	2540-01-136-0981	46522	55102-G2
6	27		46522	A55106-G1
6	28	5330-01-269-7454	46522	A55314-G1
7	1	5340-01-098-6048	78385	G704625
7	2	5310-00-333-7341	78385	487283
7	3	5310-00-061-0004	96906	MS45904-57
7	4	5940-01-054-0278	78385	735762
7	5	2540-01-234-4874	78385	G705030
7	6	5305-00-181-0877	57733	170123
7	7	5330-01-054-9752	78385	704667
7	8	5940-01-058-6470	78385	G705362
7	9	5940-00-983-6082	81349	38TB4
7	10	5305-01-097-8180	78385	488066
7	11	2540-01-079-4637	78385	G705353
7	12	5305-00-984-6191	96906	MS35206-243
7	13	5306-01-059-0188	78385	704555
7	14	5930-01-077-7793	78385	704401
7	15	5930-00-283-6562	78385	G704526
7	16	5305-00-984-4983	96906	MS35206-226
7	17	2520-00-216-5722	78385	704225
7	18	5325-00-827-2057	79497	KA56BR101
7	19	5325-01-129-0277	78385	705356
7	20	4710-01-077-7720	78385	G704288-2
7	21	4520-00-217-5782	16236	OS-4520-SV-0705
7	22	5975-01-067-3359	78385	703129
7	23	5999-01-059-6609	78385	700380
7	24	6150-01-058-3466	78385	G704683
7	25	6150-01-058-3465	78385	G704682
7	26	5310-00-606-8281	78385	488756
8	1	4810-01-171-4644	78385	G705990
8	2	5310-00-934-9762	96906	MS35649-286
8	3	5310-01-234-9416	96906	MS51412-2
8	4		78385	705931
8	5	5310-00-138-4315	96906	MS51859-5
8	6		78385	G705903-7
8	7		78385	G705903-5
8	8	5970-01-142-3179	78385	735447-5
8	9		78385	704447-1
8	10	5305-01-146-1664	78385	704436
8	11	6150-01-054-0297	78385	G702562-27
8	12	5930-01-077-7793	78385	704401
8	13	4730-00-278-0187	96906	MS39171-12
8	14		78385	720942
8	15		78385	G705850
8	16	5360-00-790-6071	78385	489209
8	17	2940-00-456-1573	78385	414677
8	18		78385	705836
8	19	5305-00-115-9934	96906	MS51849-55
8	20		78385	7705846
8	21	5330-01-008-6527	78385	704406
8	22		78385	704883

CROSS-REFERENCE INDEXES

FIG.	ITEM	FIGURE AND ITEM NUMBER INDEX		PART NUMBER
		STOCK NUMBER	CAGEC	
8	23		78385	705841
8	24		78385	705845
8	25	5360-00-327-5879	78385	476339
8	26	5330-00-285-5114	57733	474669
8	27	2540-01-169-5137	78385	G705558
8	28		78385	705556
8	29	5310-00-285-5112	78385	476229
8	30		78385	G7055989-44
8	31	2540-01-162-3640	78385	705557-1
8	32	5305-00-145-0828	78385	701761
8	33	5305-01-057-9322	78385	704435
8	34		78385	704431-3
8	35	5307-01-136-8740	78385	705345
8	36	5895-01-230-0266	78385	705840
8	37		78385	705847
8	38	4540-01-210-2693	78385	705843
8	39	5330-00-138-4440	96906	MS9068-115
8	40		78385	705842
8	41	5330-01-008-6523	78385	735411
8	42	4820-01-057-5925	78385	704579
8	43		78385	705838
9	1		78385	G705225
9	1		78385	G706144
9	2	5305-00-984-6191	96906	MS35206-243
9	3	2540-00-608-8102	78385	488773
9	4		78385	G706166
9	4	2540-01-077-7724	78385	G705102
9	5		78385	OONL
9	6	5975-01-077-2222	78385	703129
9	7	5961-01-037-0687	78385	G705241
9	7	5961-01-270-9631	78385	G706159
9	8	6150-01-054-0296	78385	701226-24
9	9	5305-00-115-9406	96906	MS51849-53
9	10		78385	G704974
9	11	6105-00-234-1278	78385	G704557
9	11	6105-01-269-8467	78385	G706149
9	12		78385	G705230
9	13		78385	705236
9	14	6110-01-097-3342	19207	11669574
9	15	2540-00-706-5159	78385	G700749
9	16	5310-00-934-9757	96906	MS35649-282
9	17		57733	G706147
9	17	4140-00-763-1228	57733	G489276
9	18	2540-01-077-7723	78385	G704656
9	19	4710-01-054-0313	78385	704635
9	20		78385	G704612
10	1	5305-00-226-7222	96906	MS35273-44
10	2	2540-01-136-8703	78385	G738396
10	3	5325-01-134-3826	78385	738448
10	4		78385	G705294-1
10	5	5305-01-097-8180	78385	488066

CROSS-REFERENCE INDEXES

FIG.	ITEM	FIGURE AND ITEM NUMBER INDEX STOCK NUMBER	CAGEC	PART NUMBER
10	6	2510-01-136-8713	78385	G705300
10	7	5330-01-109-5947	78385	704980
10	8		78385	G705293
10	9	5340-01-047-6031	78385	722058
10	10	5306-01-059-0188	78385	704555
10	11	5310-00-765-3197	96906	MS27183-41
10	12	5310-00-934-9757	96906	MS35649-282
10	13	2540-01-162-3641	78385	738460-2
10	14		57733	700042
10	15	5330-01-162-3745	78385	705692
10	16	5310-01-137-6801	78385	704190
10	17	6105-01-171-4722	78385	G705319-1
10	18	5325-00-827-2057	92872	3191
10	19		78385	G705292
10	20	2540-01-136-8715	78385	G705368
10	21		78385	719676
10	22	6150-01-136-8730	78385	G705377
10	23	6110-01-075-2799	78385	G705320
10	23	6110-01-276-2053	78385	G706157
10	24	5975-01-067-3359	78385	703129
10	25	2590-01-136-8714	78385	G705315
10	26	5305-00-181-0877	57733	170123
10	27	5330-01-162-7031	78385	705691
10	28		78385	170315
10	29	5310-00-823-8804	96906	MS27183-9
10	30	5340-01-136-8707	78385	705340
10	31	5330-01-109-5945	78385	730050-2
10	32	5340-01-109-5671	78385	G705065
10	33	5305-01-066-3431	78385	705032
10	34	4710-01-054-0313	78385	704635
10	35	2540-01-136-8705	78385	G705341
10	36	4730-01-168-4255	78385	705640-1
10	37	4720-01-175-0513	78385	738457
10	38	5325-01-134-3825	78385	736641
10	39	4730-01-162-3833	78385	705640-2
11	1		78385	G705081
11	2	5310-00-878-7196	96906	MS21043-08
11	3	2540-01-057-5714	78385	G705080
11	4	9390-01-070-5959	19207	11663062-1
11	5	5310-01-126-0466	78385	705078
11	6		78385	705136
11	7	5310-01-059-0988	78385	705135
11	8		78385	705079
11	9	5310-01-126-0467	78385	705116
11	10		78385	704190
11	11	2540-01-057-7443	78385	704623
11	12	5305-01-136-8734	78385	705117
11	13		78385	G705209
11	14	5305-01-066-3431	78385	705032
12	1	5310-12-171-2242	D8435	201144260003
12	2	2540-12-171-3201	D8435	251244010003

CROSS-REFERENCE INDEXES

FIG.	ITEM	FIGURE AND ITEM NUMBER INDEX STOCK NUMBER	CAGEC	PART NUMBER
12	3	5305-12-142-5547	D8046	007985005127
12	4	5310-12-142-0657	D8435	171 22 084
12	5	5999-12-167-3600	D8435	25 1447 01 04 00
12	6	5905-12-167-3198	D8435	25 1244 01 05 00
12	7	6685-12-167-1067	D8435	20 1348 03 00 32
12	8	4730-12-140-3653	D8773	S10/9ZY
12	9	5930-12-167-3195	D8435	25 1244 99 35 00
12	10	5935-12-171-9976	D8512	925075
12	11	5940-12-171-2844	D8435	25 1214 15 09 00
12	12	5305-12-142-5659	D8435	108 10 323
12	13	5325-12-171-6731	D8435	20 1101 01 00 05
12	14	5910-12-171-5192	D8435	25 1244 01 06 00
12	15	2540-12-167-3599	D8435	25 1431 01 00 03
12	16	2920-12-171-1836	D8435	206 00 150
12	17	5930-12-167-3196	D8435	25 1244 01 07 00
12	17		D8773	DIN72571-1X7-ST-VERZINKT
13	1		D8435	CA 50 14451
13	2	5975-00-025-7947	06090	222D163-4
13	3	5935-12-171-8132	D8435	206 31 002
13	4	5935-12-171-5488	D8435	206 31 013
13	5	5935-01-143-4665	00779	180923
13	6		04618	480115-1
13	7	5935-00-481-2012	00779	480003-5
13	8	5935-12-198-9039	08512	1-63007-0
13	9	5961-00-023-3900	14933	L00695
13	10	5935-12-171-5507	D8435	206 31 301
13	11	5975-12-171-8479	D8435	132 75 071
13	12	5935-12-171-8131	D8435	20631304
13	13	4810-12-167-1474	D8435	25 1244 05 02 00
13	14	4730-00-908-3194	96906	MS35842-11
13	15	5310-00-925-9645	96906	MS21083N04
13	16	5310-00-167-0834	88044	AN960-10L
14	1	5340-01-151-2742	19207	12293275-3
14	2	2540-01-114-7458	19207	12300356
14	3	5310-00-167-0721	96906	MS35333-41
14	4	5310-00-829-9981	96906	MS35649-2312
14	5		19207	12300346-1
14	6	4730-12-136-1127	D8435	10 2063 01 20 90
14	7		19207	12300346-2
14	8	4730-12-162-0513	D8435	104-10-008
14	9	4730-12-196-3832	D8435	25 1352 88 0005
14	10	5340-01-222-7986	19207	12329199
14	11	4730-01-134-8294	19207	12300470
14	12	4730-01-151-2740	19207	12300453-2
14	13	4730-01-151-2754	19207	12300453-1
14	14	5310-00-925-9645	96906	MS21083N04
14	15	5310-00-950-1310	96906	MS27183-4
14	16	5305-00-958-5457	96906	MS35190-226
14	17		19207	12300346-3
14	18	4730-01-269-1233	19207	12300480

CROSS-REFERENCE INDEXES

FIG.	ITEM	FIGURE AND ITEM NUMBER INDEX STOCK NUMBER	CAGEC	PART NUMBER
14	19		D8435	360 75 110
14	20	4730-01-118-3691	96906	MS24521-1
14	21	5330-12-156-5014	D2081	50000900
15	1	2540-12-167-3601	D8435	25 1426 45 00 00
15	2	2540-12-190-9540	D8435	25 1452 45 00 00
15	3	4730-00-908-3193	96906	MS35842-12
15	4		19207	201449001001-1
15	5	5310-00-043-0520	96906	MS35650-3252
15	6	2540-12-171-3208	D8435	20 1550 51 00 00
15	7	2540-12-171-3207	D8435	25 1244 53 00 00
15	8	5310-00-809-4058	96906	MS27183-10
15	9	5310-00-159-6209	96909	MS122032
15	10	5305-00-914-6125	96906	MS51095-304
16	1	2540-12-171-3408	D8435	25 1244 01 00 02
16	2		D8435	103 10 307
16	3	5310-12-142-0656	D8286	B4DIN127A3P
16	4	5365-12-153-6444	D8435	171 22 006
16	5	4140-12-171-6366	D8435	25 1426 15 02 00
16	6		D8435	103 10 063
16	7	5310-12-142-0659	D8435	171 22 086
16	8	6105-12-172-4011	D8435	25 1244 15 04 00
16	9	3010-12-172-3646	D8435	25 1426 99 55 00
16	10	5975-12-171-8130	D8435	209 31 070
16	11	5915-12-171-6732	D8435	25 1244 15 05 00
16	12	4530-12-171-2045	D8435	25 1244 15 01 00
16	13	5330-12-171-2725	D8435	25 1226 01 00 04
16	14	5330-12-171-6331	D8435	25 1244 89 01 01
16	15		D8435	25 1244 06 00
16	16	5340-12-171-2845	D8435	10 2062 19 22 09
16	17	5310-12-126-3830	D8435	110 10 025
16	18	5310-12-142-0657	D8435	171 22 084
16	19	5330-12-157-7529	D8435	20 8542 11 00 02
16	20	2540-12-171-3410	D8435	25 1244 01 08 00
16	21		D8435	25 1244 02 00 00
16	22	5325-12-171-5193	D8435	20 1280 09 01 03

APPENDIX E
ILLUSTRATED LIST OF MANUFACTURED ITEMS
Section 1. INTRODUCTION

This appendix includes complete instructions for making items authorized to be manufactured or fabricated at Organizational and Direct Support Maintenance levels.

a part number in alphanumeric order is provided for cross-referencing the part number of the item to be manufactured to the figure which covers fabrication criteria.

All bulk materials needed for manufacture of an item are listed by part number or specification number in a tabular list on the illustration.

(1) ITEM NUMBER	(2) LEVEL	PART NUMBER (FSCM)	(4) DESCRIPTION (FSCM)	(5) U/M
1	0		Exhaust Doughnut Insert (page E-1)	
2	F		Fuel Line Hose Assemblies (page E-2)	

Section II. MANUFACTURED ITEMS ILLUSTRATIONS

ITEM 1.
EXHAUST DOUGHNUT
INSERT

**NOTE: FABRICATE
FROM MATERIAL WITH
SUFFICIENT STIFFNESS
TO COVER INTAKE OPENING
WITHOUT COLLAPSING**

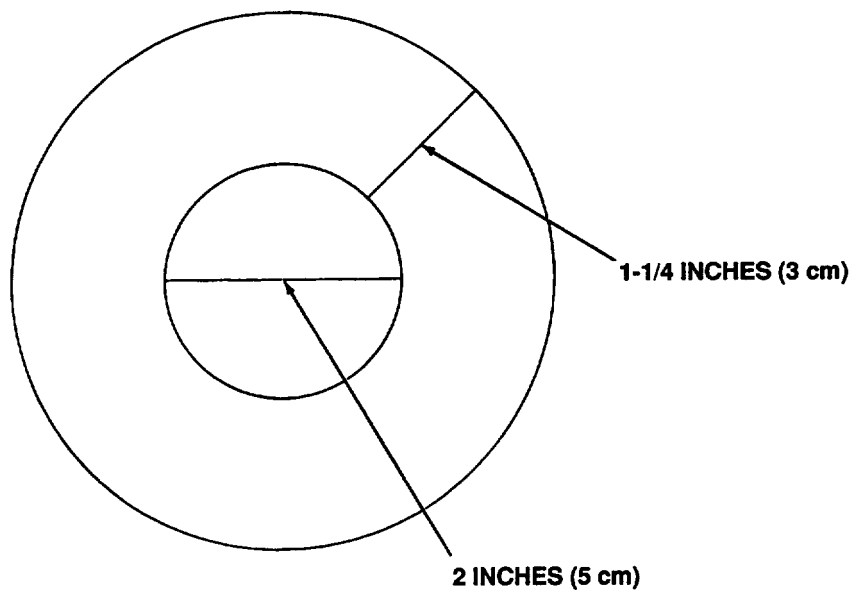

Section II. MANUFACTURED ITEMS ILLUSTRATIONS-CONTINUED

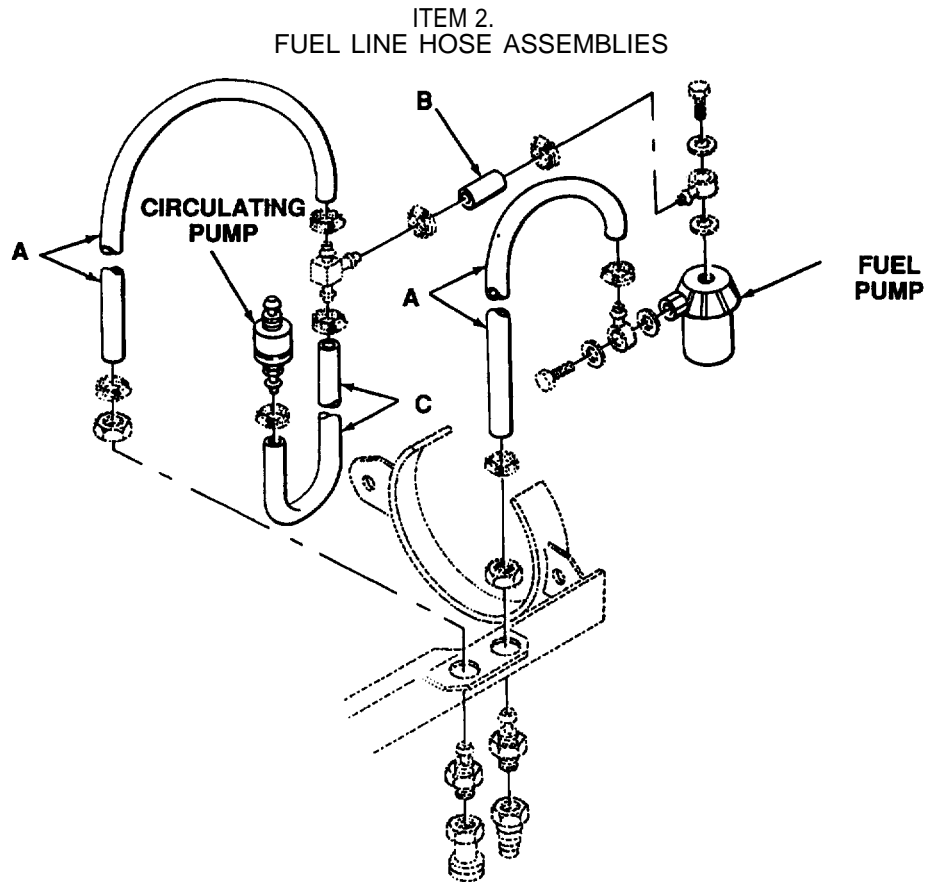

NOTES:
THE DIMENSIONS ARE GIVEN FOR EACH HOSE ASSEMBLY. LENGTHS INCLUDE ONLY THE NONMETALLIC HOSE.

NSN 4720-00-486-7167-HOSE, NONMETALLIC

- A. 7 1/4 inches (18 cm) (two required)
- B. 2 1/4 inches (6 cm)
- C. 8 1/2 inches (22 cm)

INDEX

Subject	Page
A	
Air Flow System; Principles of Operation,	
Espar V7S	1-24
Hupp Models	1-21
Stewart-Warner 10560C24	1-15
Stewart-Warner 10560M, 10560M24B1, 10560G	1-14
Appendix A; References	
Forms	A-1
Other Publications	A-1
Publication Indexes and General References	A-1
Appendix B; Maintenance Allocation Chart	B-1
Explanation of Columns in the MAC, Sectional	B-2
Explanation of Columns in Tool and Test Equipment Requirements, Section III	B-3
Explanation of Columns in Remarks, Section IV	B-3
General	
Introduction, Section I	B-1
Maintenance Allocation Chart	B-4
Maintenance Functions	B-1
Appendix C; Expendable Supplies and Materials List	C-1
Appendix D; Repair Parts and Special Tools List	D-1
Appendix E; Illustrated List of Manufactured Items	E-1

B

Blower Assembly-Hupp Models	3-62
Assembly	3-69
Disassembly	3-65
Installation	3-69
Removal	3-62
Blower Assembly-Stewart-Warner 10560C24, 10560G	3-99
Assembly	3-102
Disassembly	3-100
Installation	3-104
Removal	3-99
Blower Assembly-Stewart-Warner 10560M, 10560M24B1	3-105
Assembly	3-109
Disassembly	3-105
Installation	3-111
Removal	3-105
Blower Motor and Impeller-Espar V7S	3-185
Installation	3-186
Removal	3-185
Burner Assembly and Heat Exchanger-Espar V7S	3-188
Installation	3-190
Removal	3-188

INDEX - Continued

Subject Page

B - Continued

Burner Plate-Hupp Models	3-60
Inspection/Cleaning	3-60
Installation	3-61
Removal	3-60
Burner Repair-Stewart-Warner 10560C24, 10560M, 10560M24B1,10560G	3-131
Assembly	3-133
Cleaning/Inspection	3-133
Disassembly	3-131
Burner Replacement-Stewart-Warner 10560C24,10560G	3-125
Installation	3-125
Removal	3-125
Burner Replacement-Stewart-Warner 10560M,10560M24B1	3-127
Installation	3-129
Removal	3-127
Test	3-16
Burner Thermostat/Preheater Assembly-Hupp Models	3-58
Installation	3-59
Removal	3-58
Test	3-5

C

Capacitor Hupp MF60A-24V, MF60B-24V	3-39
Installation	3-39
Removal	3-39
Characteristics, Capabilities, and Features, Equipment	1-2
Circulating Pump-Espar V7S	3-174
Installation	3-174
Removal	3-174
Cleaning Instructions; General Maintenance Instructions	2-2
Common Tools and Equipment; Direct Support and General Support Maintenance	3-1
Control Bracket Assembly, Hupp Models	3-34
Installation	3-37
Removal	3-34
Replacement	3-36

D

Data, Equipment	1-10
Data Plates; Location	1-8
Description and Data, Equipment	1-2

INDEX - Continued

Subject Page

D - Continued

Destruction of Army Materiel to Prevent Enemy Use 1-1

Differences Between Models 1-9

Diode Mounting Assembly-Stewart-Warner 10560C24, 10560G 3-120

 Installation 3-120

 Removal 3-120

Diode Mounting Assembly-Stewart-Warner 10560M, 10560M24B1 3-122

 Installation 3-123

 Removal 3-122

 Test 3-14

Direct Support and General Support Maintenance 3-1

Direct Support and General Support Maintenance,
Maintenance Procedures 3-26

 Repair Parts, Special Tools; Test, Measurement and Diagnostic
 Equipment (TMDE): and Support Equipment 3-1

 Test Procedures.. . . . 3-192

Direct Support and General Support Troubleshooting Procedures,
Explanation of Columns 3-2

 Introduction 3-2

 Symptom Index 3-2

 Troubleshooting 3-3

 Air Flow System; Principles of operation 1-21

E

Equipment Description and Data 1-10

 Differences Between Models 1-9

 Equipment Characteristics, Capabilities, and Features 1-2

 Equipment Data-Stewart-Warner 1-11

 Location and Description of Major Components 1-2

 Location of Data Plates 1-8

EsparV7S,
Blower Motor and Impeller 3-185

Burner Assembly and Heat Exchanger 3-188

Circulating Pump 3-174

Fixed Capacitor 3-146

Fixed Wire Resistor 3-146

Fuel Lines and Fittings 3-169

Fuel Pump 3-176

Fuel System; Principles of Operation 1-22

Glow Plug 3-138

Heat Regulator 3-179

Hood 3-135

Ignition Spark Generator 3-136

Ignition System; Principles of Operation 1-23

INDEX - Continued

Subject Page

E-Continued

Espar V7S, Continued

Impulse Switch	3-181
Mounting Assembly	3-163
Overheat Switch	3-148
Radio Filter	3-183
Shut-Down Procedure	2-61
Solenoid Valve	3-152
Start-Up Procedures	2-61
Temperature Sensor	3-140
Terminal Board...	3-150
Thermostatic Switch	3-142
Wiring Diagram	3-25
Wiring Harness	3-154
Wiring Harness Repair	3-161
Expendable Supplies and Materials List	C-1
Explanation of Columns; Expendable Supplies and Materials List	C-1
Explanation of Columns: Maintenance Allocation Chart	B-2
Explanation of Columns in the MAC, Sectional	B-2
Explanation of Columns in Tool and Test Equipment Requirements, Section III	B-3
Explanation of Columns in remarks, Section IV	B-3
Explanation of Columns: Organizational Maintenance	2-15

F

Fixed Capacitor-EsparV7S	3-144
Installation	3-144
Removal	3-144
Fixed Wire Resistor-EsparV7S	3-146
Installation	3-146
Removal	3-146
Flame Detector Switch-Hupp Models	2-33
Adjustment	2-34
Installation	2-33
Removal	2-33
Test	2-17
(Flame Detector Switch) Stewart-Warner 10560C24, 10560M, 10560M24B1, 10560G Thermostatic Switch	3-72
Assembly	3-73
Disassembly	3-72
Test	2-24

INDEX - Continued

Subject Page

F - Continued

Forms and Records, Maintenance	1-1
Forms; References	A-1
Fuel Lines and Fittings-Espar V7S	3-169
Installation	3-171
Removal	3-169
Fuel Pump-Espar V7S	3-176
Installation	3-177
Removal	3-176
Fuel Regulator Valve-Hupp Models	3-47
Adjustment	3-53
Assembly	3-49
Disassembly	3-49
Installation	3-51
Removal	3-41
Fuel Regulator Valve-Stewart-Warner 10560C24, 10560M	3-74
Adjustment	3-84
Assembly	3-80
Cleaning	3-78
Disassembly.... ..	3-75
Inspection/Replacement.	3-79
Installation	3-82
Removal	3-74
Fuel System: Principles of Operation,	
EsparV7S	1-22
Hupp Models	1-19
Stewart-Warner10560C24	1-16
Stewart-Warner 10560M, 10560M24BI, 10560G	1-17

INDEX - Continued

Subject	Page
G	
General Information	1-1
Destruction of Army Materiel to Prevent Enemy Use	1-1
Maintenance Forms and Records	1-1
Reporting Equipment Improvement Recommendations (EIR'S)	1-1
scope	1-1
General Information; General Maintenance Instructions	2-2
General Maintenance Allocation Chart	B-1
General Maintenance Instructions	2-1
Cleaning Instructions	2-2
Electrical Tiedown Straps	2-1
General Information	2-2
Inspection Instructions	2-3
Repair Instructions ,	2-4
scope	2-1
Tagging Wires and Hoses	2-3
Work Safety	2-1
Glow Plug-Espar V7S	3-138
Installation	3-138
Removal	3-138
Guard-Hupp Models	2-32
Installation ,	2-32
Removal	2-32
Guard-Stewart-Warner 10560C24, 10560M, 10560M24B1, 10560G	2-42
Installation ... ,	2-42
Removal	2-42

H

Heat Regulator-Espar V7S	3-179
Installation	3-180
Removal	3-179
Heater Thermostat-Hupp Models	3-57
Installation ... , , ,	3-57
Removal	3-57
Hi/LO Fire Relay, Hupp Models ,	3-30
Installation	3-30
Removal ,	3-30
Hood-Espar V7S ,	3-135
Installation	3-135
Removal	3-135

INDEX - Continued

Subject	Page
H - Continued	
Hupp Models; Direct Support and General Support	
Maintenance Troubleshooting procedures	3-3
Hupp Models	
Air Flow System; Principles of Operation.	1-21
Blower Assembly	3-62
Burner Thermostat/preheater Assembly.	3-58
Hupp Models	
Burner Plate.	3-60
Control Bracket Assembly	3-34
Electrical Connector	3-27
Flame Detector Switch	2-33
Fuel Regulator Valve.	3-47
Fuel System; Principles of Operation	1-19
Guard	2-32
HeaterThermostat.	3-57
HI/LO Fire Relay	3-30
Ignition System; Principles of Operation	1-20
Igniter.	2-35
Ignitor Relay (Hupp MF510B only).	3-41
Organizational Troubleshooter	2-16
Overheat Switch Assembly	3-57
Valve Relay, All Models.	3-32
Valve Thermostat.. . . .	2-37
voltage Regulator(HuppMF510c, MF60-24V, MF60B-24V).	3-41
Wiring Diagram	2-13
Hupp Models	
Shut-Down Procedure	2-61
Start-Up Procedures	2-60

I

Ignition Control-Stewart-Warner 10560C24, 10560M, 10560M24BI, 10560-G	2-47
Installation	2-47
Removal	2-47
Test	2-23
Ignition Spark Generator-EsParv7S	3-136
Installation	3-136
Removal	3-136
Ignition System: Principles of Operation,	
EsparV7S	1-23

INDEX - Continued

Subject	Page
I - Continued	
Hupp Models	1-20
Stewart-Warner10560C24, 10560M, 10560M24B1, 10560G	1-18
Ignitor-HuppModels	2-35
Installation	2-35
Removal	2-35
TestD/S	3-4
Test Unit	2-16
Ignitor Relay-HuppMF510B, (Voltage Regulator-HuppMF510C)	3-41
Installation	3-41
Removal	3-41
Test	3-8
Ignitor-Stewart-Warner 10560C24, 10560M, 10560M24B1, 10560G	2-49
Installation	2-51
Removal	2-49
impulse Switch-EsparV7S	3-181
Installation	3-182
Removal	3-181
Inspection Instructions; General Maintenance Instructions	2-3
Drilled and Tapped (Threaded) Holes	2-3
Machined Metal Parts	2-3
Metal Lines, Flexible Lines (Hoses), and Metal Fittings	2-3
Introduction	1-1
Introduction; Expendable Supplies and Materials List	C-1
Introduction; illustrated List of Manufactured Items	E-1
Introduction; Maintenance Allocation Chart	B-1
General	B-1
Maintenance Functions	B-1
Introduction; Organizational Maintenance	2-15

L

Leakage Definitions; Organizational Maintenance	2-7
Location and Description of Major Components	1-2
Espar ModelV7S	1-6
Hupp Models	1-3
Stewart-Warner Models 10560C24, 10560M,10560M24B1, 10560G	1-5
Location of Data Plates	1-8
Espar ModelV7S	1-8
Hupp Models	1-8
Stewart-Warner Model 10560C24, 10560M,10560M24B1, 10560G	1-8

INDEX - Continued

Subject	Page
M	
Maintenance Allocation Chart	B-1
Maintenance Forms and Records	1-1
Major Components; Location and Description	1-2
Manufactured Items; illustrated List of	E-1
Manufactured Items illustrations, Section II	E-1
Materials List Expendable Supplies	C-1
Motor Direct Current Hupp Models	3-62
Assembly	3-67
Disassembly	3-65
Installation	3-69
Removal	3-62
Test	3-6
Moto, Direct Current Stewart-Warner 10560C24, or 10560G	
Assembly	3-102
Disassembly	3-100
Installation	3-104
Removal	3-99
Test	3-13
Mounting Assembly-Espar V7S	3-163
Installation.	3-165
Removal.	3-163

O

Operation, Principles of	1-13
Basic Heater Operation	1-13
Espar V7S	1-22
Hupp Models	1-19
Stewart-Warner 10560C24, 10560M	1-15
Stewart-Warner 10560M24B1, 10560G	1-14
Organizational Maintenance	2-1
General Maintenance Instructions	2-1
Organizational Maintenance Procedures	2-15
Organizational Preventive Maintenance Checks and Services (PMCS)	2-6
Organizational Troubleshooting Procedures	2-15
Repair Parts, Special Tools; Test Measurement and Diagnostic Equipment(TMDE); and Support Equipment	2-5
Service Upon Receipt	2-5
Start-Up Procedures	2-59
Organizational Maintenance Procedures	2-15
Flame Detector Switch-Hupp Models	2-33
Fuel Regulator Valve-Hupp Models	2-39
Fuel Regulator Valve-Stewart-Warner 10560C24, 10560M	2-57
Pulsed Fuel Metering Valve, 10560M24B1, 10560G	2-57
Guard-Hupp Models	2-32
Guard-Stewart-Warner 10560C24, 10560M, 10560M24B1, 10560G	2-42

INDEX - Continued

Subject

P a g e

O - Continued

Ignition Control-Stewart-Warner 10560C24, 10560M, 10560M24B1, 10560G	2-47
Ignitor-Hupp Models , , , ,	2-35
Ignitor-Stewart-Warner 10560C24, 10560M, 10560M24B1	2-4g
Overheat Switch-Stewart-Warner 10560C24, 10560M, 10560M24B1	2-53
Pulsed Fuel Metering Valve, 10560M24BI, ,10560G and	3-88
Fuel Regulator Valve, Stewart-Warner 10560C24, 10560M.	3-74
Thermostatic Switch (Flame Detector Switch) Stewart-Wamer 10560C24, 10560M, 10560M24B1	2-43
Valve Thermostat-Hupp Models	2-37
Valve Thermostat-Stewart-Warner 10560C24, 10560M,10560M24B1, 10560G	2-55
organizational preventive Maintenance Checks and Services (PMCS)	2-6
General.	2-6
Leakage Definitions	2-7
Organizational Preventive Maintenance Checks and Services (PMCS)	2-8
PMCS Column Description	2-7
Special Instructions	2-6
OrganizationalTroubleshooting	2-16
Symptom Index	2-15
Wiring Diagrams.	2-13
Organizational Troubleshooting Procedures	2-15
Explanation of Columns	2-15
Introduction	2-15
Other Publications; References	A-1
Overheat Switch, Espar7VS	3-148
Installation	3-148
Removal	3-148
Overheat Switch-Stewart-Warner 10560C24, 10560M,10560M24B1 ,10560G	2-53
Installation	2-53
Removal	2-53
Test, D/S	3-4
Test, Unit	2-25
Overview,	
Direct Support and General Support Maintenance	3-1
Introduction	1-1
Organizational Maintenance	2-1

INDEX - Continued

Subject	Page
P	
PMCS Column Description; Organizational Maintenance	2-7
Power Control Hupp, MF60A-24V, MF60B-24V, MF510C	3-43
Installation	3-45
Removal	3-43
Test	3-45
Preheater Assembly/Burner Thermostat-Hupp Models	3-58
Installation	3-59
Removal	3-58
Principles of Operation	1-13
Basic Heater Operation	1-13
EsparV7S	1-22
Hupp Models	1-19
Stewart-Warner 10560C24,	1-15
Stewart-Warner 10560M24B1, 10560M, 10560G	1-14
Publication Indexes and General References	A-1
Pulsed Fuel Metering Valve-Stewart-Warner 10560M24B1, 10560G	3-88
Adjustment	3-96
Assembly	3-93
Cleaning/Inspection	3-92
Disassembly	3-90
Installation	3-96
Removal	3-88
Test	3-17
R	
Radio Filter- Espar V7S	3-183
Installation	3-183
Removal	3-183
Receptacle Connector-Hupp Models	3-27
Installation	3-28
Removal	3-27
References	A-1
Relay,HI/LO Fire Hupp Models	3-30
Installation	3-30
Removal	3-30
Test	3-9
Repair Instructions; Organizational Maintenance	2-4

INDEX - Continued

Subject

P a g e

R - Continued

Repair Parts, Special Tools Test, Measurement and Diagnostic
 Equipment (TMDE); and Support Equipment,
 Direct Support and General Support Maintenance 3.1
 Organizational Maintenance 2-5
 Reporting Equipment Improvement Recommendations (EIR'S) 1-1

S

Semiconductor Device /Diode Mounting Assembly) -Stewart-Warner 10560C24, 10560G 3-120
 Installation 3-120
 Removal 3-120
 Test 3-14
 Scope 1-1
 Scope, Expendable Supplies and Materials List..... C-1
 Service Upon Receipt; Organizational Maintenance 2-5
 Shut-Down Procedure-Stewart-Warner, Hupp, and Espar Heaters 2-61
 Solenoid Valve-Espar V7S 3-152
 Installation 3-153
 Removal 3-152
 Special instructions; Organizational Maintenance 2-6
 Start-Up Procedures; Organizational Maintenance 2.59
 Espar V7S 2-61
 Hupp Heaters 2-60
 Stewart-Warner Heaters 2-59
 Stewart-Warner 10560C24, 10560G
 Air Flow System; Principles of Operation 1-15
 Blower Assembly 3-99
 Burner Replacement 3-125
 Diode Mounting Assembly 3-122
 Fuel System; Principles of Operation 1-16
 Voltage Regulator Assemby 3-114
 Stewart-Warner 10560G
 Air Flow System; Principles of Operation 1-14
 Fuel System; Principles of Operation 1-17

INDEX - Continued

Subject Page

S - Continued

Stewart-Warner 10560M24B1, 10560M	
Air Flow System; Principles of Operation	1-14
Fuel System; Principles of Operation	1-17
Pulsed Fuel Metering Valve (10560M24B1 only)	3-88
Stewart-Warner 10560C24, 10560G	
Fuel Regulator Valve	3-74
Principles of Operation	1-13
Wiring Diagram	2-14
Stewart-Warner 10560M, 10560M24B1	
Blower Assembly	3-105
Burner Replacement	3-127
Voltage Regulator Assembly	3-116
Stewart Warner 10560C24, 10560M,10560M24BI, 10560G	
Burner Repair	3-131
Fuel Regulator Valve (except 10560M24B1)	3-74
Guard	2-42
Ignition Control	2-47
Ignition System; principles of operation	1-18
Igniter	2-49
Organizational Troubleshooting	2-16
Overheat Switch.	2-53
Pulsed Fuel Metering Valve, 10560M24B1	3-88
Thermostatic Switch (Flame Detector Switch), Organizational Maintenance	3-72
Thermostatic Switch (Flame Detector Switch) Repair	3-72
Troubleshooting; Direct Support and General Support Maintenance	3-3
Valve Thermostat	2-55
Stewart-Warner Heaters,	
Shut-Down Procedure	2-61
Start-Up Procedures	2-59
Supplies and Materials List Expendable	C-1
Symptom Index; Direct Support and General Support Maintenance	3-2
Symptom Index, Organizational Maintenance	2-15

INDEX - Continued

Subject

Page

T

Tagging Wires and Hoses; Organizational Maintenance 2-3

Temperature Sensor-Espar V7S 3-140

 Installation 3-140

 Removal 3-140

Terminal Board-Espar V7S 3-150

 Installation 3-150

 Removal 3-150

Test Procedures 3-192

Thermostat Assembly Hupp MF510C, MF60A-24V, MF60B-24V 2-37

 Installation 2-37

 Removal 2-37

 Test 2-18

Thermostatic Switch-Espar V7S 3-142

 Installation 3-142

 Removal 3-142

Thermostat Switch (Flame Detector Switch)-Stewart-Warner 10560C24,
10560M, 10560M24B1, 10560G 2-43

Terminal Strip 2-45

 Installation 2-45

 Removal 2-45

Tool Identification List B-8

Tools and Test Equipment Requirements; Maintenance Allocation Chart B-8

Troubleshooting; Direct Support and General Support Maintenance 3-3

Troubleshooting Procedures

 Direct Support and General Support Maintenance 3-2

V

Valve Relay-Hupp Models 3-32

 Installation 3-32

 Removal 3-32

 Test 3-3

Valve, Solenoid Espar V7S 3-152

ValveThermostat Stewart-Warner 10560C24,10560M, 10560M24B1,10560G 2-55

 Installation 2-55

 Removal 2-55

 Test 2-25

Voltage Regulator Assembly-Stewart-Warner 10560C24,10560G 3-114

 Installation 3-114

 Removal 3-114

 Test 3-11

INDEX - Continued

Subject Page

V - Continued

Voltage Regulator Assembly-Stewart-Warner, 10560M, 10560M24B1	3-116
Installation	3-118
Removal	3-116
Test	3-11

W

Wiring Diagrams	
Espar V7S	3-25
Hupp Models	2-14
Stewart-Warner 10560C24, 10560G	2-14
Stewart-Warner 10560M24B1, 10560M	2-14
Wiring Harness-Espar V7S	3-154
Installation	3-157
Removal	3-154
Wiring Harness Repair-Espar V7S	3-161
Connector and Terminal Installation	3-161
Connector and Terminal Removal	3-161

By Order of the Secretary of the Army:

GORDON R. SULLIVAN
General, United States Army
Chief of Staff

Official:

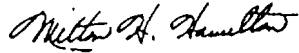

MILTON H. HAMILTON
Administrative Assistant to the
Secretary of the Army

01261

Distribution:

To be distributed in accordance with DA Form 12-38-E (Block 0712) Unit, Direct Support and General Support maintenance requirements for TM9-2540-205-24&P.

RECOMMENDED CHANGES TO EQUIPMENT TECHNICAL PUBLICATIONS



THEN JOT DOWN THE DOPE ABOUT IT ON THIS FORM. CAREFULLY TEAR IT OUT. FOLD IT AND DROP IT IN THE MAIL

SOMETHING WRONG WITH THIS PUBLICATION?

FROM (PRINT YOUR UNIT'S COMPLETE ADDRESS)
Co. B, 1st BN, 2nd BRIGADE
Ft. Hood, TX 76445

DATE SENT 17 DEC 1989

PUBLICATION NUMBER
TM 9-2350-264-10-1

PUBLICATION DATE

PUBLICATION TITLE Operator Controls, PMCS, and Operation Under Usual Conditions

BE EXACT PIN-POINT WHERE IT IS

PAGE NO	PARA. GRAPH	FIGURE NO	TABLE NO
3		2	
109		51	
2-B			2-1
12	1-6a		

IN THIS SPACE TELL WHAT IS WRONG AND WHAT SHOULD BE DONE ABOUT IT:

Item 10. Change illustration. Reason: Tube end shown assembled on wrong side of lever cam

Item 3. The NSN and P/N are not listed on the AMDF nor the MCRL. Request correct NSN and P/N be furnished.

Preventive Maintenance Check and Services. Item 7 under "Items to be inspected" should be changed to read as follows: Firing linkage and firing mechanism pawl.

Since there are both 20- and 30- round magazines for this rifle, data on both should be listed.

SAMPLE

PRINTED NAME GRADE OR TITLE AND TELEPHONE NUMBER
Pete Moss 1LT AV272-4162

SIGN HERE
Pete Moss

FILL IN YOUR
UNIT'S ADDRESS



DEPARTMENT OF THE ARMY
Co. B, 1st BN, 2nd BRIGADE
Ft. Hood, TX 76445

OFFICIAL BUSINESS

Commander
U.S. Army Tank-Automotive Command
ATTN: AMSTA-MB
Warren, MI 48397-5000

SAMPLE

TEAR ALONG PERFORATED LINE

RECOMMENDED CHANGES TO EQUIPMENT TECHNICAL PUBLICATIONS



SOMETHING WRONG WITH THIS PUBLICATION?

THEN... JOT DOWN THE DOPE ABOUT IT ON THIS FORM. CAREFULLY TEAR IT OUT. FOLD IT AND DROP IT IN THE MAIL!

FROM: (PRINT YOUR UNIT'S COMPLETE ADDRESS)

DATE SENT

PUBLICATION NUMBER
TM 9-2540-205-24&P

PUBLICATION DATE
10 Apr 92

ORG 25/06
OPERATOR'S MAINTENANCE MANUAL (INCLUDING RPSTL) FOR HEATERS, VEHICULAR COMPARTMENT

BE EXACT PIN-POINT WHERE IT IS				IN THIS SPACE TELL WHAT IS WRONG AND WHAT SHOULD BE DONE ABOUT IT:
PAGE NO	PARA-GRAPH	FIGURE NO	TABLE NO	

PRINTED NAME, GRADE OR TITLE AND TELEPHONE NUMBER

SIGN HERE

DA FORM 2028-2
1 JUL 79

PREVIOUS EDITIONS ARE OBSOLETE.

P.S.--IF YOUR OUTFIT WANTS TO KNOW ABOUT YOUR RECOMMENDATION MAKE A CARBON COPY OF THIS AND GIVE IT TO YOUR HEADQUARTERS

FILL IN YOUR
UNIT'S ADDRESS



FOLD BACK

DEPARTMENT OF THE ARMY

OFFICIAL BUSINESS

Commander
U.S. Army Tank-Automotive Command
ATTN: AMSTA-MB
Warren, MI 48397-5000

TEAR ALONG PERFORATED LINE

RECOMMENDED CHANGES TO EQUIPMENT TECHNICAL PUBLICATIONS



THEN... JOT DOWN THE DOPE ABOUT IT ON THIS FORM. CAREFULLY TEAR IT OUT. FOLD IT AND DROP IT IN THE MAIL!

SOMETHING WRONG WITH THIS PUBLICATION?

FROM: (PRINT YOUR UNIT'S COMPLETE ADDRESS)

DATE SENT

PUBLICATION NUMBER

TM 9-2540-205-24&P

PUBLICATION DATE

10 Apr 92

ORG. DS/CS MAINTENANCE MANUAL
(INCLUDING RPSTL) FOR HEATERS,
VEHICULAR COMPARTMENT

BE EXACT PIN-POINT WHERE IT IS

PAGE
NO

PARA-
GRAPH

FIGURE
NO

TABLE
NO

IN THIS SPACE TELL WHAT IS WRONG
AND WHAT SHOULD BE DONE ABOUT IT:

PRINTED NAME, GRADE OR TITLE AND TELEPHONE NUMBER

SIGN HERE

DA FORM 2028-2
1 JUL 79

PREVIOUS EDITIONS
ARE OBSOLETE.

P S --IF YOUR OUTFIT WANTS TO KNOW ABOUT YOUR
RECOMMENDATION MAKE A CARBON COPY OF THIS
AND GIVE IT TO YOUR HEADQUARTERS

FILL IN YOUR
UNIT'S ADDRESS



FOLD BACK

DEPARTMENT OF THE ARMY



OFFICIAL BUSINESS

Commander
U.S. Army Tank-Automotive Command
ATTN: AMSTA-MB
Warren, MI 48397-5000

TEAR ALONG PERFORATED LINE

RECOMMENDED CHANGES TO EQUIPMENT TECHNICAL PUBLICATIONS



SOMETHING WRONG WITH THIS PUBLICATION?

THEN... JOT DOWN THE DOPE ABOUT IT ON THIS FORM. CAREFULLY TEAR IT OUT. FOLD IT AND DROP IT IN THE MAIL!

FROM: (PRINT YOUR UNIT'S COMPLETE ADDRESS)

DATE SENT

PUBLICATION NUMBER
TM 9-2540-205-24&P

PUBLICATION DATE
10 Apr 92

ORG. DS/CG MAINTENANCE MANUAL
(INCLUDING RPSTL) FOR HEATERS,
VEHICULAR COMPARTMENT

BE EXACT PIN-POINT WHERE IT IS				IN THIS SPACE TELL WHAT IS WRONG AND WHAT SHOULD BE DONE ABOUT IT:
PAGE NO	PARA-GRAPH	FIGURE NO	TABLE NO	

PRINTED NAME, GRADE OR TITLE AND TELEPHONE NUMBER

SIGN HERE

DA FORM 2028-2
1 JUL 79

PREVIOUS EDITIONS ARE OBSOLETE.

P.S. --IF YOUR OUTFIT WANTS TO KNOW ABOUT YOUR RECOMMENDATION MAKE A CARBON COPY OF THIS AND GIVE IT TO YOUR HEADQUARTERS

FILL IN YOUR
UNIT'S ADDRESS



FOLD BACK

DEPARTMENT OF THE ARMY

OFFICIAL BUSINESS

Commander
U.S. Army Tank-Automotive Command
ATTN: AMSTA-MB
Warren, MI 48397-5000

TEAR ALONG PERFORATED LINE

THE METRIC SYSTEM AND EQUIVALENTS

LINEAR MEASURE

1 Centimeter=10 Millimeters=0.01 Meters=0.3937 Inches
 1 Meter=100 Centimeters=1000 Millimeters=39.37 Inches
 1 Kilometer=1000 Meters=0.621 Miles

WEIGHTS

1 Gram=0.001 Kilograms=1000 Milligrams=0.035 Ounces
 1 Kilogram=1000 Grams=2.2 Lb
 1 Metric Ton=1000 Kilograms=1 Megagram=1.1 Short Tons

LIQUID MEASURE

1 Milliliter=0.001 Liters=0.0338 Fluid Ounces
 1 Liter=1000 Milliliters=33.82 Fluid Ounces

SQUARE MEASURE

1 Sq Centimeter=100 Sq Millimeters=0.155 Sq Inches
 1 Sq Meter=10,000 Sq Centimeters=10.76 Sq Feet
 1 Sq Kilometer=1,000,000 Sq Meters=0.386 Sq Miles

CUBIC MEASURE

1 Cu Centimeter=1000 Cu Millimeters=0.06 Cu Inches
 1 Cu Meter=1,000,000 Cu Centimeters=35.31 Cu Feet

TEMPERATURE

$5/9 (^{\circ}F - 32) = ^{\circ}C$
 212 $^{\circ}$ Fahrenheit is equivalent to 100 $^{\circ}$ Celsius
 90 $^{\circ}$ Fahrenheit is equivalent to 32.2 $^{\circ}$ Celsius
 32 $^{\circ}$ Fahrenheit is equivalent to 0 $^{\circ}$ Celsius
 $9/5 C^{\circ} + 32 = F^{\circ}$

APPROXIMATE CONVERSION FACTORS

<u>TO CHANGE</u>	<u>TO</u>	<u>MULTIPLY BY</u>
Inches	Centimeters	2.540
Feet	Meters	0.305
Yards	Meters	0.914
Miles	Kilometers	1.609
Square Inches	Square Centimeters	6.451
Square Feet	Square Meters	0.093
Square Yards	Square Meters	0.836
Square Miles	Square Kilometers	2.590
Acres	Square Hectometers	0.405
Cubic Feet	Cubic Meters	0.028
Cubic Yards	Cubic Meters	0.765
Fluid Ounces	Milliliters	29.573
Pints	Liters	0.473
Quarts	Liters	0.946
Gallons	Liters	3.785
Ounces	Grams	28.349
Pounds	Kilograms	0.454
Short Tons	Metric Tons	0.907
Pound-Feet	Newton-Meters	1.356
Pounds per Square Inch	Kilopascals	6.895
Miles per Gallon	Kilometers per Liter	0.425
Miles per Hour	Kilometers per Hour	1.609

<u>TO CHANGE</u>	<u>TO</u>	<u>MULTIPLY BY</u>
Centimeters	Inches	0.394
Meters	Feet	3.280
Meters	Yards	1.094
Kilometers	Miles	0.621
Square Centimeters	Square Inches	0.155
Square Meters	Square Feet	10.764
Square Meters	Square Yards	1.196
Square Kilometers	Square Miles	0.386
Square Hectometers	Acres	2.471
Cubic Meters	Cubic Feet	35.315
Cubic Meters	Cubic Yards	1.308
Milliliters	Fluid Ounces	0.034
Liters	Pints	2.113
Liters	Quarts	1.057
Liters	Gallons	0.264
Grams	Ounces	0.035
Kilograms	Pounds	2.205
Metric Tons	Short Tons	1.102
Newton-Meters	Pound-Feet	0.738
Kilopascals	Pounds per Square Inch	0.145
Kilometers per Liter	Miles per Gallon	2.354
Kilometers per Hour	Miles per Hour	0.621

